

SPECIFICATIONS



Model Number: ST24S3H
Part Number: 19032397A

SHREV.A
 September 7, 2010

Mechanical Drawing:

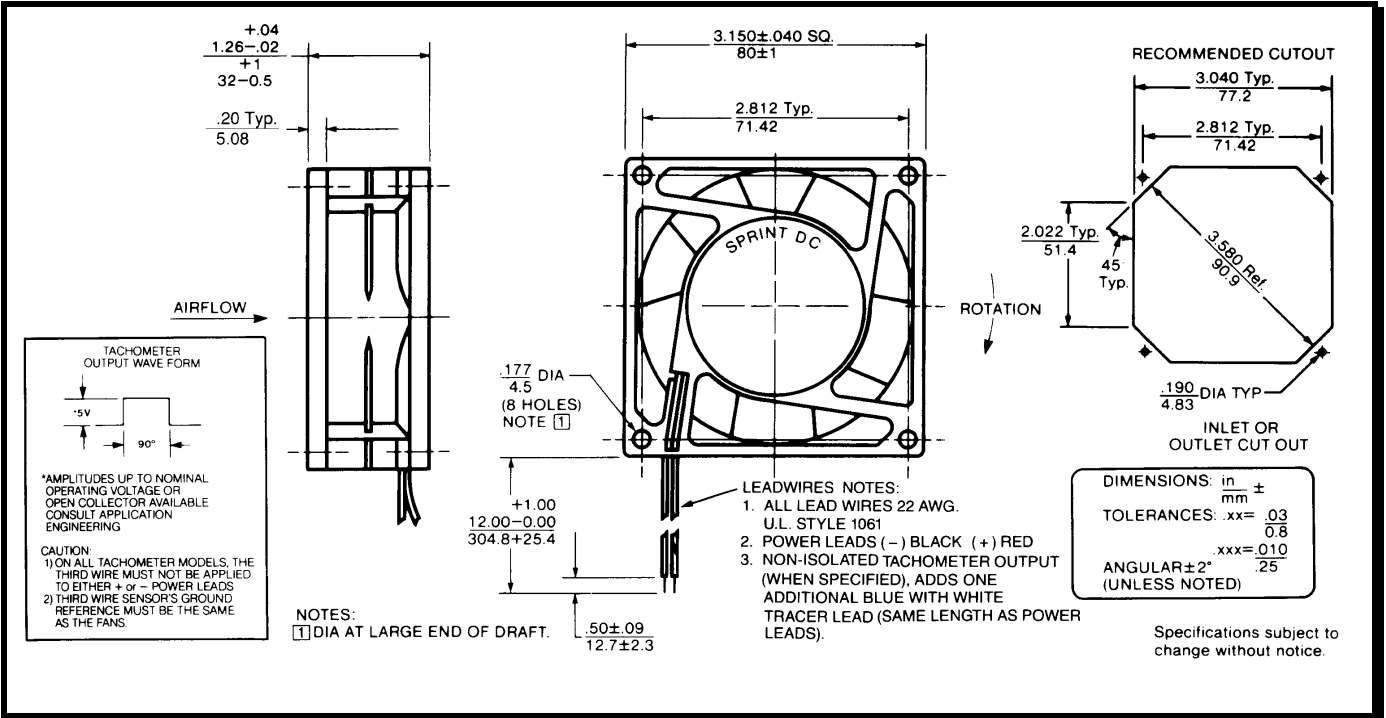

Motor (full speed):

Nominal Voltage	= 24 vdc
Operating Voltage Range	= 12 - 28 vdc
Nominal Running Current	= .160 amps
Max. Locked Rotor Current	= .440 amps
Running Power	= 3.8 watts
Average Speed	= 3500 RPM
Bearings	= Ball Bearing
Air Flow	= 34 CFM
Acoustic	= 40.2 dBA

Construction:

Venturi: Plastic, Black, UL 94V-0
 Propeller: Plastic, Black, UL 94V-0

Life Expectancy:

This fan is designed for continuous duty life of 78,000 hours at 40°C.

Additional Features:

Brushless DC Motor
 Locked Rotor Protection
 Polarity Protection
 Thermal Speed Control
 Automatic Restart Capability
 Operating Temperature: -10°C to 70°C
 Storage temperature: -40°C to 85°C
 Thermal Speed Control

Termination:

Thermistor on 25" zip cord
 12" Lead wires, 22 AWG, UL 1061
 Red = Power (+)
 Black = Return (-)

Agency Approvals

UL,