

RECOMMENDED  
CABLE STRIPPING DIM'S

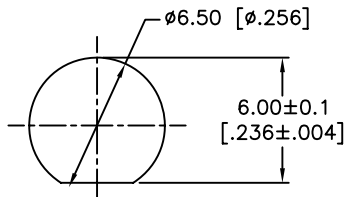

RECOMMENDED  
MOUNTING HOLE

REV.	DATE	ECR NO.	DESCRIPTION
A	01/23/04	-	UPDATE DRAWING FORMAT
B	04/23/08	100009	MODIFY BARREL O.D., FERRULE O.D. AND I.D.
	04/18/11	2159	CHANGE FLATS ON BULKHEAD TO ALIGN WITH THE POINT ON THE HEX NUT

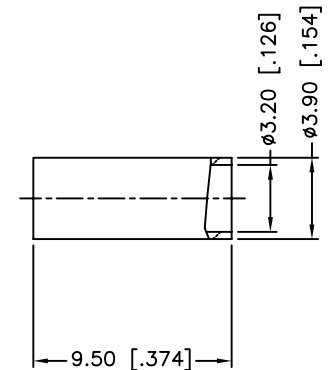
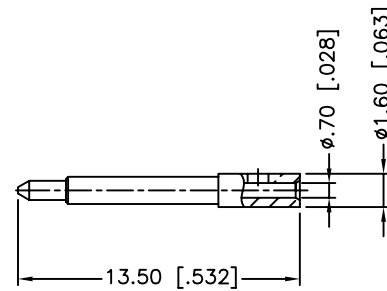
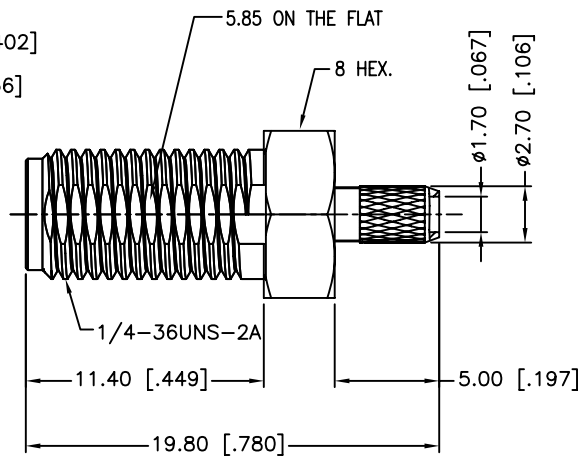
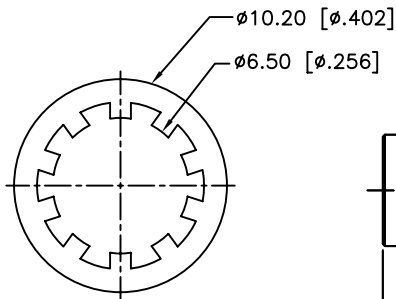
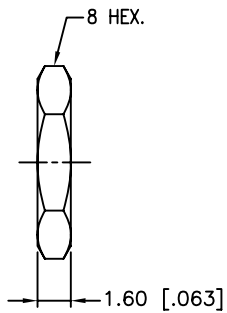
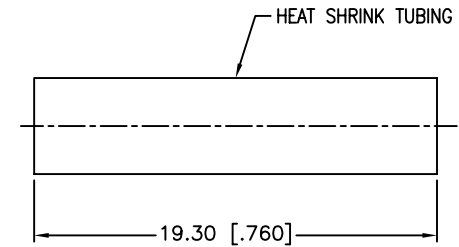
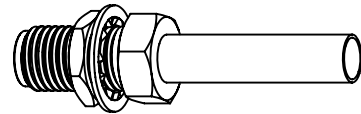

NOTE:  
 1. CRIMPED FERRULE HEX CRIMP SIZE .128"  
 2. CONTACT PIN TO SOLDER  
 3. MAX. PANEL THICKNESS=3.2mm

DESCRIPTION	MATERIAL	FINISH	QTY
HEAT SHRINK TUBING		BLACK	
FERRULE	BRASS	GOLD	1
HEX NUT	BRASS	GOLD	1
LOCK WASHER	BRASS	GOLD	1
CONTACT PIN	BRASS	GOLD	1
INSULATOR	PTFE	NATURAL	1
BODY	BRASS	GOLD	1

UNLESS OTHERWISE SPECIFIED DIMENSIONS ARE IN MILLIMETERS. DIMENSIONS IN [ ] ARE IN INCHES AND FOR CUSTOMER REFERENCE ONLY.

UNLESS OTHERWISE SPECIFIED TOLERANCES FOR MILLIMETERS ARE:  
 0.5 - 8mm ± 0.20mm  
 8 - 30mm ± 0.40mm  
 30 - 120mm ± 0.50mm

UNLESS OTHERWISE SPECIFIED TOLERANCES FOR INCHES ARE:  
 .020 - .315 = ± 0.007"  
 .315 - 1.180 = ± 0.015"  
 1.180 - 4.724 = ± 0.020"

DO NOT SCALE DRAWING

APPROVALS	DATE
DRAWN M.ZHANG	04/18/11
CHECKED	
ISSUED	
SHEET 1 OF 1	
CAD FILE F:/CONNEX/132119RP.DWG	

<b>Amphenol Connex</b>			
PART DESCRIPTION			
SMA REVERSE POLARITY BULKHEAD CRIMP JACK (FOR RG-174/U,188A/U,316/U CABLE)			
PART NO.			
132119RP			
DWG. NO.	132119RP.DWG	REV. B	SIZE A
			SCALE NA