



8 dBi RHCP Panel Antenna 902-928 MHz SMA Connector

Antennas Technical Data Sheet

PE51FP1008-3

Features

- Right Hand Circular Polarized
- Compact Size
- Low Profile
- 4 ft Coax Lead with SMA Male Connector
- Lightweight ASA Radome

Applications

- LPWAM, LoRA, IoT, M2M Applications
- 900 MHz ISM Band Applications
- 900 MHz Cellular
- RFID, GSM, SCADA
- Wireless Video Links

Description

The Pasternack PE51FP1008-3 is a high performance right hand circular polarized wall mount panel antenna designed to operate in the 900 MHz (860-960 MHz) band. These antennas feature circular polarization which makes them ideal for RFID applications.

Compact and low profile, the PE51FP1008-3 antenna features 8 dBi of gain with a 65° beam width. Equipped with an SMA male connector, the PE51FP1008-31 from Pasternack connects easily to most commercial radios. This panel mount antenna, as well as our wide selection of superior quality RF devices, ships same day. Contact our knowledgeable and friendly technical support and sales staff for your answers on antennas or other Pasternack products.

Configuration

Design	RHCP Panel
Application Band	RFID SCADA LPWAN ISM
Band Type	Single
Radiation Pattern	Directional
Polarization	RHCP
Cable Type	Coax Cable
Cable Length	48 in [121.92 cm]
Connector Type	SMA Male
Number of Ports	1

Electrical Specifications

Description	Minimum	Typical	Maximum	Units
Frequency Range	902		928	MHz
Input VSWR		1.5:1	1.5:1	
Impedance		50		Ohms
Gain		8		dBi
Horizontal (Azimuth) Beam Width		65		Degrees
Vertical (Elevation) Beam Width		65		Degrees
Input Power			25	Watts

Click the following link (or enter part number in "SEARCH" on website) to obtain additional part information including price, inventory and certifications: [8 dBi RHCP Panel Antenna 902-928 MHz SMA Connector PE51FP1008-3](#)



8 dBi RHCP Panel Antenna 902-928 MHz SMA Connector

Antennas Technical Data Sheet

PE51FP1008-3

Specifications by Band

Description	Band 1	Band 2	Band 3	Band 4	Band 5	Units
Range	902-928					MHz
Gain	8					dBi
Horizontal Beam Width	65					Degrees
Vertical Beam Width	65					Degrees
Maximum Input Power	25					Watts

Mechanical Specifications

Radome Material ASA

Size

Overall Length 8.5 in [215.9 mm]
 Width 8.5 in [215.9 mm]
 Height 1.1 in [27.94 mm]
 Weight 1.17 lbs [530.7 g]

Environmental Specifications

Temperature

Operating Range -20 to +60 deg C

Environment UL-94HB

Compliance Certifications (see [product page](#) for current document)

Plotted and Other Data

Notes:

8 dBi RHCP Panel Antenna 902-928 MHz SMA Connector from Pasternack Enterprises has same day shipment for domestic and International orders. Our RF, microwave and millimeter wave products maintain a 99.4% availability and are part of the broadest selection in the industry.

Click the following link (or enter part number in "SEARCH" on website) to obtain additional part information including price, inventory and certifications: [8 dBi RHCP Panel Antenna 902-928 MHz SMA Connector PE51FP1008-3](#)

URL: <https://www.pasternack.com/single-antenna-902-928-mhz-8-dbi-gain-sma-pe51fp1008-3-p.aspx>

The information contained in this document is accurate to the best of our knowledge and representative of the part described herein. It may be necessary to make modifications to the part and/or the documentation of the part, in order to implement improvements. Pasternack reserves the right to make such changes as required. Unless otherwise stated, all specifications are nominal. Pasternack does not make any representation or warranty regarding the suitability of the part described herein for any particular purpose, and Pasternack does not assume any liability arising out of the use of any part or documentation.

PE51FP1008-3 CAD Drawing

8 dBi RHCP Panel Antenna 902-928 MHz SMA Connector

REVISIONS			
REV.	DESCRIPTION	DATE	APPROVED
A	INITIAL RELEASE	8/5/2020	K.HIETPAS

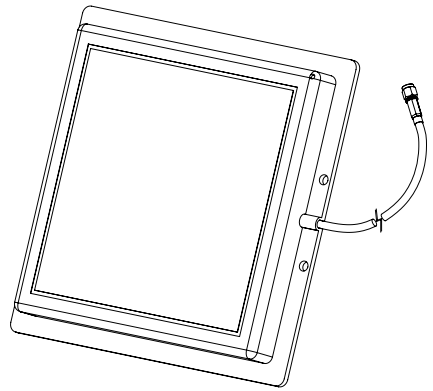
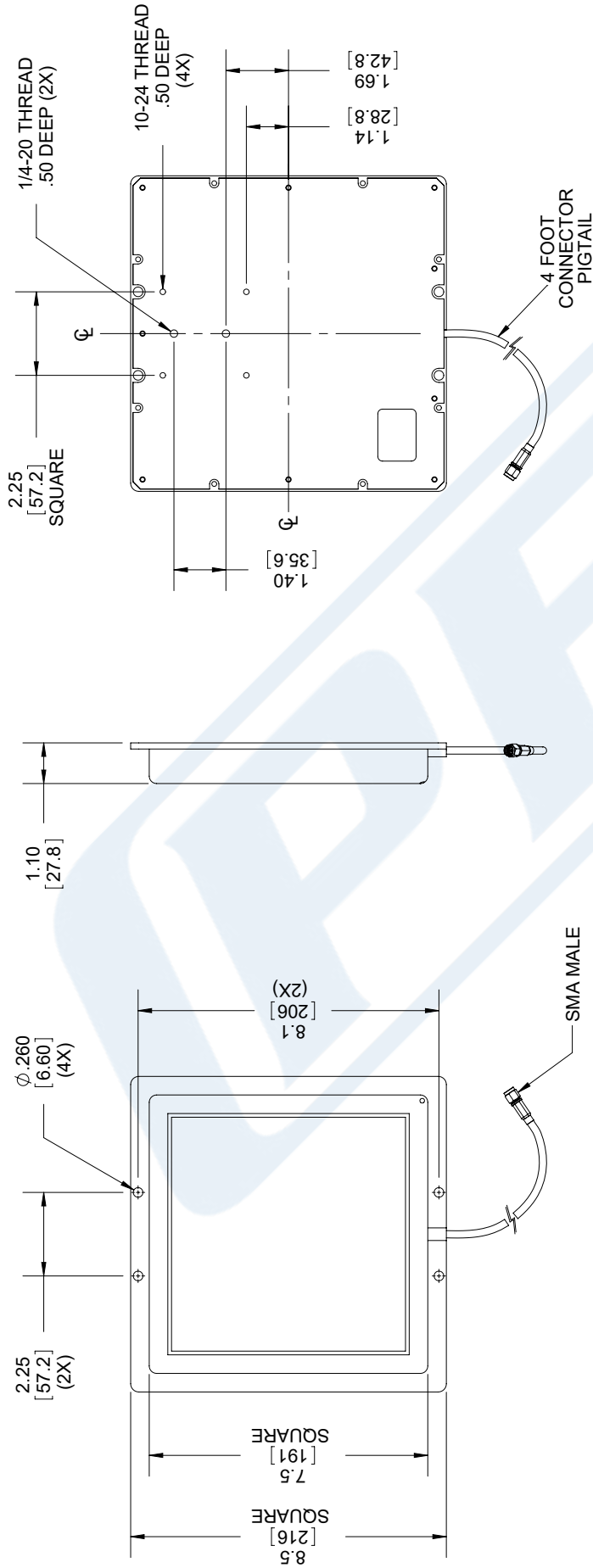

PE PASTERNAK
an INFINITO brand

Pasternack Enterprises, Inc.
P. O. Box 16759, Irvine, CA 92623.
Phone: 1.949.261.1920 | 1.866.727.8376
Fax: 1.949.261.7451
Website: www.pasternack.com
E-mail: sales@pasternack.com

THIRD-ANGLE PROJECTION

THE INFORMATION AND DESIGN IN THIS DOCUMENT IS THE PROPERTY OF PASTERNAK CORPORATION. ALL RIGHTS RESERVED.

SHEET 1 OF 1

SCALE N/A

UNLESS OTHERWISE SPECIFIED LEADING DIMENSIONS ARE INCHES DIMENSIONS IN [] ARE MILLIMETERS

TOLERANCES:

.X = ±.2	[5.08]	FRACTIONS ± 1/32
.XX = ±.02	[.51]	ANGLES ± 1°
.XXX = ±.005	[.13]	

CABLE LENGTH (L) TOLERANCES:

L ≤ 12 [305]	= +1 [25] / -0
12 [305] < L ≤ 60 [1524]	= +2 [51] / -0
60 [1524] < L ≤ 120 [3048]	= +4 [102] / -0
120 [3048] < L ≤ 300 [7620]	= +6 [152] / -0
300 [7620] < L ≤ +5% / L	-0

ALL DIMENSIONS SHOWN ARE FOR REFERENCE ONLY.

SIZE	CAGE CODE	DRAWN BY	ITEM NO
A	53919	K.DANG	PE51FP1008-3
REV			REV
			A

REGULATORY COMPLIANCE:
EU ROHS DIRECTIVE (MOST RECENT RELEASED VERSION)

THESE COMMODITIES, TECHNOLOGY OR SOFTWARE WERE EXPORTED FROM THE UNITED STATES IN ACCORDANCE WITH THE EXPORT ADMINISTRATION REGULATIONS. DIVERSION CONTRARY TO U.S. LAW PROHIBITED.