

REVISIONS					
P	LTR	DESCRIPTION	DATE	DWN	APVD
A1		REVISED PER ECR-20-100801	10NOV2020	PC	SW

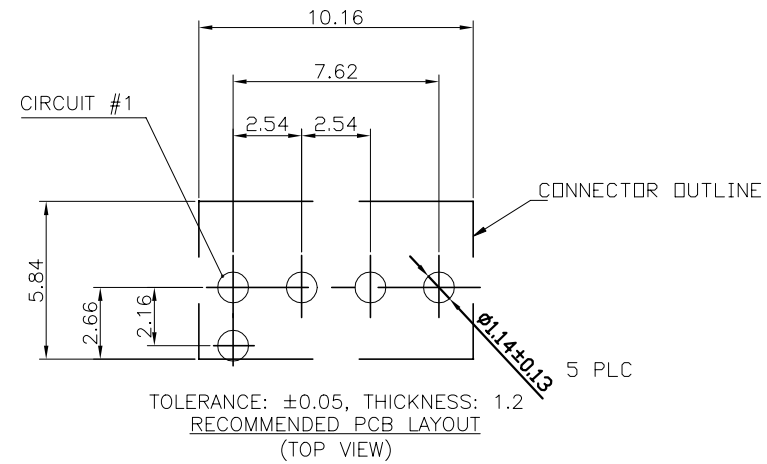
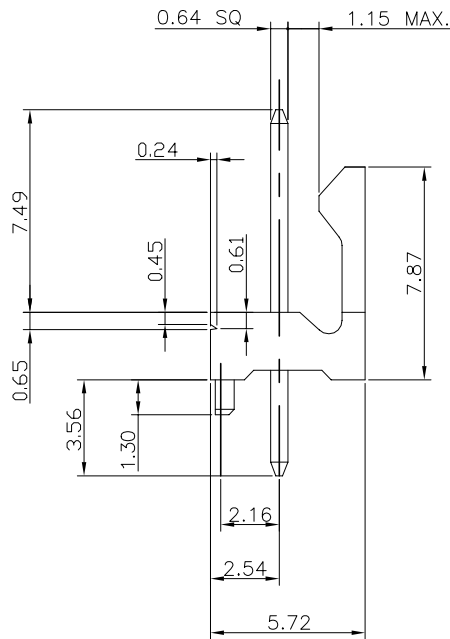
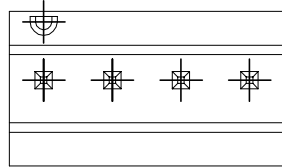
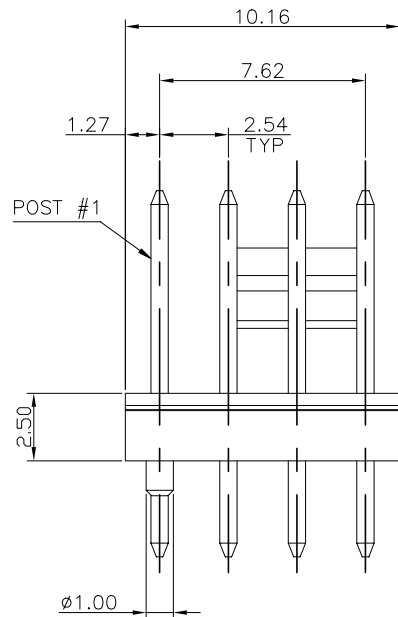
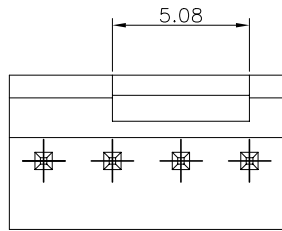

- MATERIAL:
HOUSING: THERMOPLASTIC WITH 30% GF, UL94 V-0, COLOR: (SEE TABLE)
POSTS: BRASS.
- FINISH:
POSTS: 100μ" MIN. MATTE-TIN OVER 50μ" MIN. NICKEL ON ENTIRE POST.
- WAVE SOLDER CAPABLE TO 265°C PER TE TEST SPEC. 109-202, CONDITION B.
- NO TE LOGO AND DATE CODE ON THE PRODUCT.

OBSOLETE	RED-BRICK (032C)	1734926-4
OBSOLETE	BLUE (293C)	1734926-3
OBSOLETE	WHITE	1734926-2
OBSOLETE	BLACK	1734926-1
HOUSING COLOR (PANTONE)		PART NUMBER

OBSOLETE

THIS DRAWING IS A CONTROLLED DOCUMENT.		DWN A. WU	08DEC2005	TE TE Connectivity	
DIMENSIONS: mm		CHK S. HOU	08DEC2005		
TOLERANCES UNLESS OTHERWISE SPECIFIED:		APVD WU, KF	08DEC2005	NAME	
0 PLC ± -		PRODUCT SPEC		FRICITION LOCK PIN HEADER,	
1 PLC ± 0.3		108-57470		4 POSITION, 2.54 PITCH, 0.64 SQ	
2 PLC ± 0.25		APPLICATION SPEC		-	
3 PLC ± 0.2		-		SIZE	CAGE CODE
4 PLC ± -		-		A2	00779
ANGLES ± °		-		DRAWING NO	1734926
MATERIAL SEE NOTE		WEIGHT 0.34 g		RESTRICTED TO	-
FINISH SEE NOTE		CUSTOMER DRAWING		SCALE	SHEET 1 of 2
				REV	A1

REVISIONS					
P	LTR	DESCRIPTION	DATE	DWN	APVD
-	-	SEE SHEET 1	-	-	-

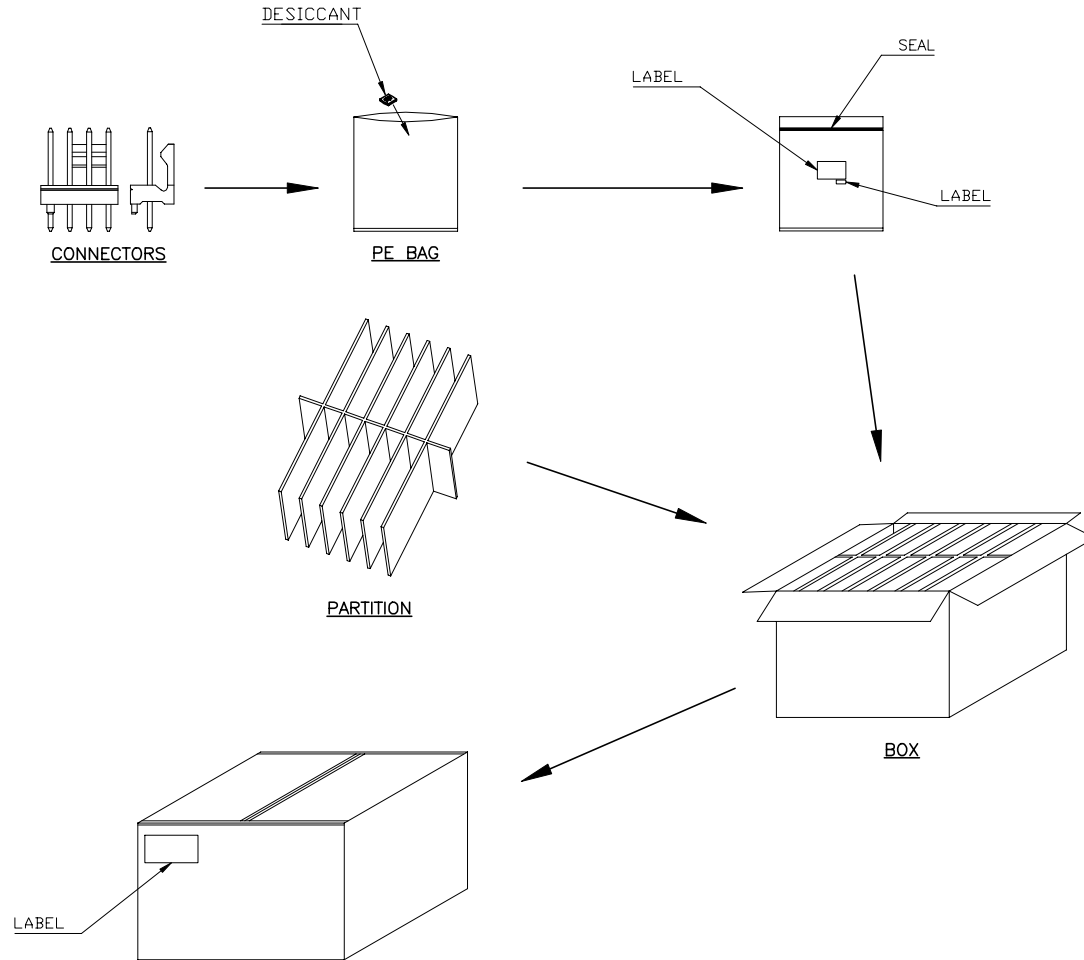

NOTES

1. DIMENSION:
PE BAG: 270 X 185 X 0.1
BOX: 372 X 293 X 172
2. QUANTITY:
1000 PCS/PE BAG
14 PE BAGS/BOX
14000 PCS/BOX
3. WEIGHT:
NET WEIGHT: 5.6 KG
GROSS WEIGHT: 6.4 KG

OBSOLETE

1734926

THIS DRAWING IS A CONTROLLED DOCUMENT.		DWN A. WU	08DEC2005	TE Connectivity																									
DIMENSIONS: mm		CHK S. HOU	08DEC2005																										
TOLERANCES UNLESS OTHERWISE SPECIFIED:		APVD W.J. KF	08DEC2005	NAME FRICITION LOCK PIN HEADER, 4 POSITION, 2.54 PITCH, 0.64 SQ																									
<table border="1"> <tr><td>0</td><td>PLC</td><td>±</td><td>-</td></tr> <tr><td>1</td><td>PLC</td><td>±</td><td>0.3</td></tr> <tr><td>2</td><td>PLC</td><td>±</td><td>0.25</td></tr> <tr><td>3</td><td>PLC</td><td>±</td><td>0.2</td></tr> <tr><td>4</td><td>PLC</td><td>±</td><td>-</td></tr> <tr><td colspan="2">ANGLES</td><td>±</td><td>∇</td></tr> </table>		0	PLC	±	-	1	PLC	±	0.3	2	PLC	±	0.25	3	PLC	±	0.2	4	PLC	±	-	ANGLES		±	∇	PRODUCT SPEC 108-57470		SIZE A2	
0	PLC	±	-																										
1	PLC	±	0.3																										
2	PLC	±	0.25																										
3	PLC	±	0.2																										
4	PLC	±	-																										
ANGLES		±	∇																										
MATERIAL SEE NOTE		FINISH SEE NOTE		APPLICATION SPEC -																									
WEIGHT 0.34 g		CAGE CODE A2 00779		DRAWING NO 1734926																									
CUSTOMER DRAWING		SCALE -		SHEET 2 of 2																									
REV A1		RESTRICTED TO -		REV A1																									