

REVISIONS					
P	LTR	DESCRIPTION	DATE	DWN	APVD
	H5	REVISED PER ECR-22-138429	19MAY2022	LP	DSC

**AMP**  
WIRE RANGE

---

18-16 AWG  
STRANDED

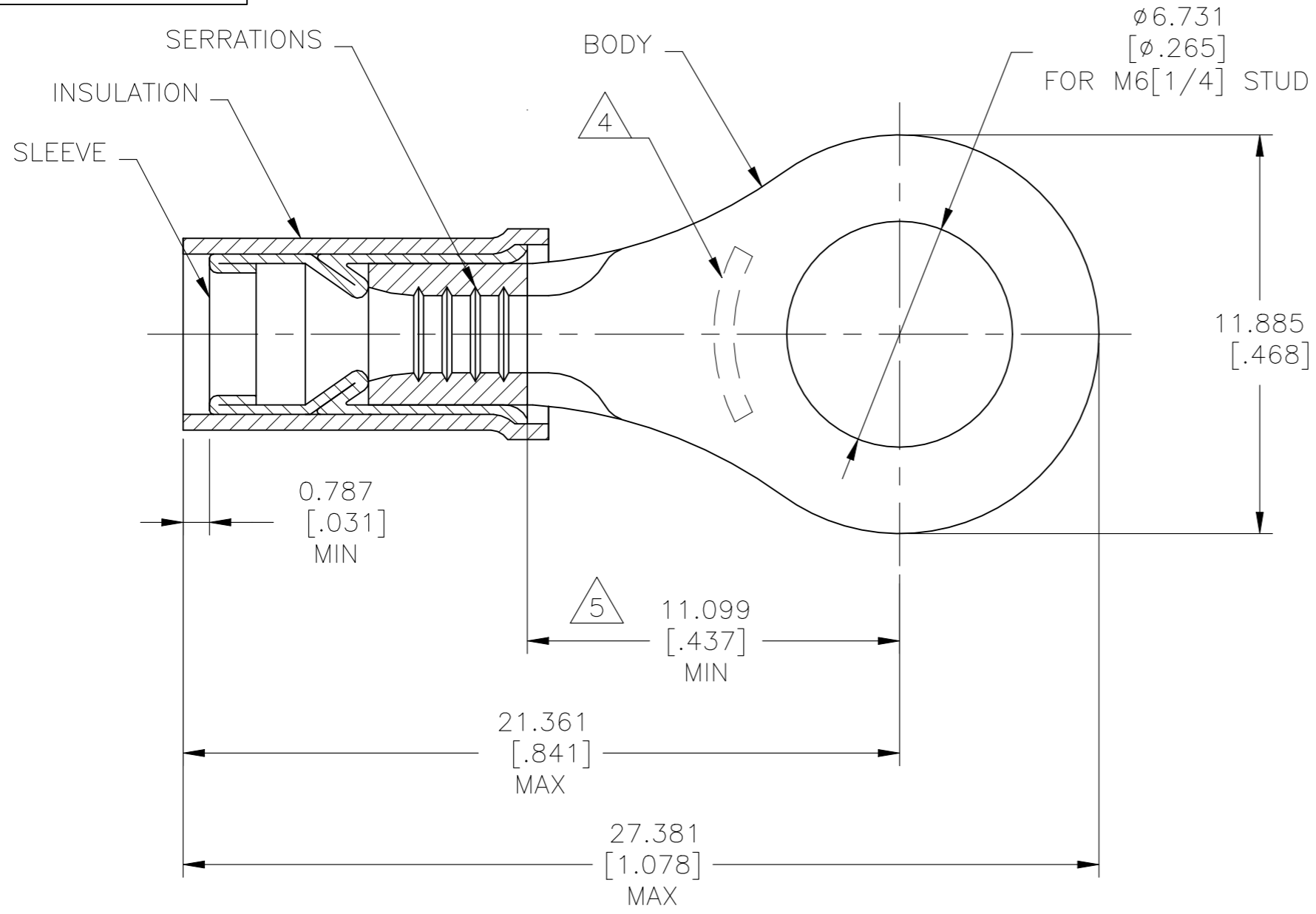

- 1 MATERIAL:  
BODY & SLEEVE - COPPER PER ASTM B152  
INSULATION - PTFE PER ASTM D4895
- FINISH:  
BODY - NICKEL PLATE 0.00762[.00030]  
AVG EXT THK PER SAE AMS-QQ-N-290  
SLEEVE - NICKEL PLATE 0.001651[.000065]  
AVG EXT THK PER SAE AMS-QQ-N-290  
INSULATION COLOR - ORANGE
- 2 FOR 1.397[.055] TO 3.429[.135] WIRE  
INSULATION DIA.
- 3 BODY MATERIAL THK: 0.787±0.051[.031±.002]
- 4 STAMP AMP 18-16\* APPROX AS SHOWN
- 5 DIMENSION APPLIES FROM EDGE OF  
METAL WIRE BARREL TO CENTER OF  
STUD HOLE

1000	LOOSE PIECE	50837
QTY	PACKAGE TYPE	PART NO.

AMP INCORPORATED CUSTOMER SERVICE SYSTEMS		MAX RECOMMENDED OPERATING TEMPERATURE: 288°C [550°F]	THIS DRAWING IS A CONTROLLED DOCUMENT.		DWN 13OCT2015 NAGALAKSHMI K	<b>STE</b> TE Connectivity				
FOR ADDITIONAL PRODUCT INFORMATION OR COPIES OF DRAWINGS AND TECHNICAL DOCUMENTS	PRODUCT INFORMATION CENTER 1-800-522-6752	VOLTAGE RATING: 300V MAX	DIMENSIONS: mm [INCHES]	TOLERANCES UNLESS OTHERWISE SPECIFIED:	CHK 13OCT2015 MERCURIO MAURIZIO				NAME	
FOR APPLICATION TOOLING INFORMATION	TOOLING ASSISTANCE CENTER 1-800-722-1111	CIRCULAR MIL AREA: 0.81-1.42mm² [1,600-2,800] STRANDED WIRE ONLY		0 PLC ± - 1 PLC ± - 2 PLC ± - 3 PLC ± 0.127[.005] 4 PLC ± - ANGLES ± -	APVD 13OCT2015 MERCURIO MAURIZIO	TERMINAL, RING TONGUE, PIDG, STRATO-THERM, WIRE SIZE: 18-16 AWG				
FOR ORDER ENTRY	1-800-526-5142		MATERIAL	FINISH	PRODUCT SPEC -	APPLICATION SPEC 114-2162	SIZE A3	CAGE CODE 00779	DRAWING NO C-50837	RESTRICTED TO -
CUSTOMER DRAWING					SCALE NTS	SHEET 1 OF 1	REV H5			