

Spezifikation für Freigabe / specification for release

Kunde / customer :
 Artikelnummer / part number : **7490220121**
 Bezeichnung : **LAN-Übertrager WE-LAN**
 description : **LAN-Transformer WE-LAN**



DATUM / DATE : 2018-09-10

A Mechanische Abmessungen / dimensions :

1000 BaseT 4PPoE

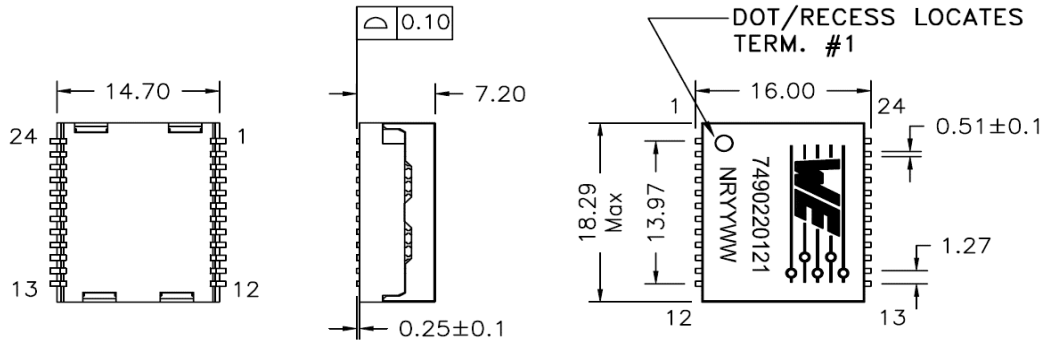

B Elektrische Eigenschaften / electrical properties :

Eigenschaften / properties	Testbedingungen / test conditions		Wert / value	Einheit / unit	tol.
Induktivität / Inductance	100kHz / 100mV @ 18mA DC-Bias	OCL	350	μH	min.
Übersetzungsverhältnis / Turns ratio	100kHz / 100mV	1CT:1CT	1 : 1	Tx	±2%
			1 : 1	Rx	
Insertion Loss	1-100MHz	IL	-1,0	dB	max.
Return Loss	1MHz - 30MHz	RL	-18	dB	min.
	30MHz - 60MHz		-14		
	60MHz - 80MHz		-12		
	80MHz - 100MHz		-10		
Common to Common Mode Rejection	1MHz - 30MHz	CMRR	-40	dB	min.
	30MHz - 60MHz		-35		
	60MHz - 100MHz		-30		
Crosstalk	1MHz - 60MHz	CT	-35	dB	min.
	60MHz - 100MHz		-30		

C Lötpad / soldering spec. :

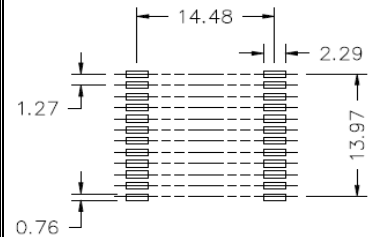

D Prüfgeräte / test equipment :

Agilent E5071C

E Testbedingungen / test conditions :

Lufffeuchtigkeit / Humidity: 33%
 Umgebungstemperatur / Temperature: +25°C

F Werkstoffe & Zulassungen / material & approvals :

Basismaterial / Base material: Ferrit / Ferrite
 Draht / Wire: 0UEW/Y 180
 Kontaktmaterial / Contact plating: Cu-Ni-Sn
 Gehäuse / Case: DAP Black per UL 94V-0

G Eigenschaften / general specifications :

Betriebstemp. / Operating temperature: -40°C - +105°C
 Hochspannungsprüfung / Hipot test: 1500Vrms 1min.
 Geeignet für 1000BaseT gemäß kommendem IEEE 802.3bt /
 Compliant with upcoming IEEE 802.3bt for 4PPoE

Freigabe erteilt / general release:

Kunde / customer			
Datum / date	Unterschrift / signature	JaB	Version 04
	Würth Elektronik	JaB	Version 03
		JaB	Version 02
		JaB	Version 01
		JaB	Preliminary
Geprüft / checked	Kontrolliert / approved	Name	Änderung / modification
			Datum / date

Würth Elektronik eiSos GmbH & Co.KG

D-74638 Waldenburg · Max-Eyth-Straße 1 - 3 · Germany · Telefon (+49) (0) 7942 - 945 - 0 · Telefax (+49) (0) 7942 - 945 - 400
<http://www.we-online.com>

Spezifikation für Freigabe / specification for release

Kunde / customer :
 Artikelnummer / part number : **7490220121**
 Bezeichnung : **LAN-Übertrager WE-LAN**
 description : **LAN-Transformer WE-LAN**



DATUM / DATE : 2018-09-10

H PoE Eigenschaften :

Designed für Anwendungen bis 600mA
 pro Mittelanzapfung
 Designed für 30W Anwendungen wenn zwei Kanäle bestromt
 Designed für 60W Anwendungen wenn vier Kanäle bestromt

H PoE Specifications :

Designed to support applications up to 600mA
 per centre tap
 Designed for 30W applications when using two channels
 Designed for 60W applications when using four channels

I Schaltbild / Schematics :

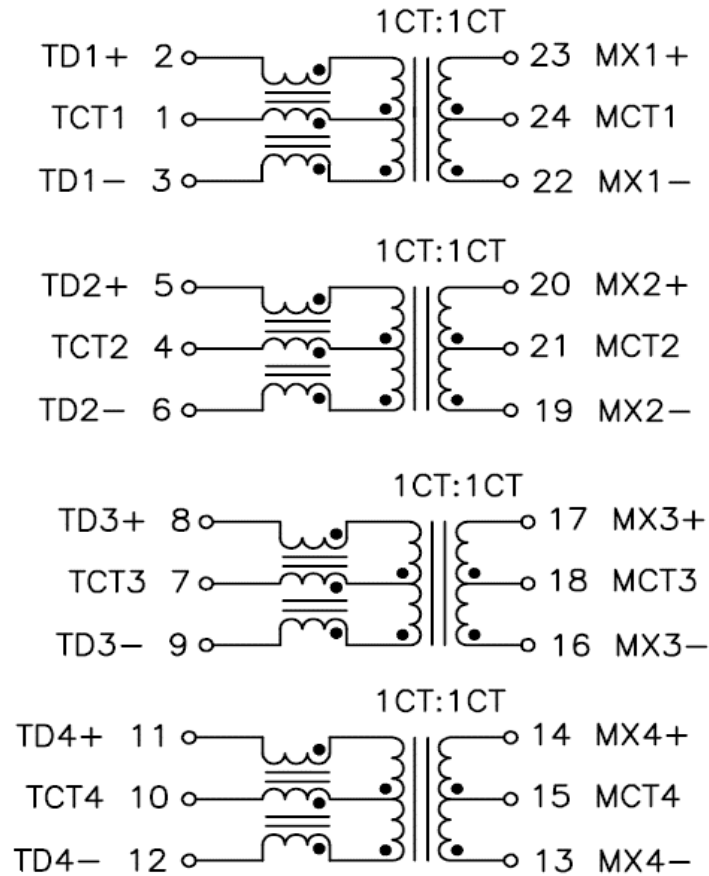

.....		
Datum / date	Unterschrift / signature	JaB	Version 04 2018-09-10
	Würth Elektronik	JaB	Version 03 2016-08-09
		JaB	Version 02 2016-07-26
		JaB	Version 01 2016-04-12
		JaB	Preliminary 2015-11-06
.....	Name	Änderung / modification Datum / date
Geprüft / checked	Kontrolliert / approved		

Würth Elektronik eiSos GmbH & Co.KG

D-74638 Waldenburg · Max-Eyth-Straße 1 - 3 · Germany · Telefon (+49) (0) 7942 - 945 - 0 · Telefax (+49) (0) 7942 - 945 - 400
<http://www.we-online.com>

Spezifikation für Freigabe / specification for release

Kunde / customer :
 Artikelnummer / part number : **7490220121**
 Bezeichnung : **LAN-Übertrager WE-LAN**
 description : **LAN-Transformer WE-LAN**



DATUM / DATE : 2018-09-10

I Rollenspezifikation / tape and reel specification :

PACKAGING(Tape & Reel)

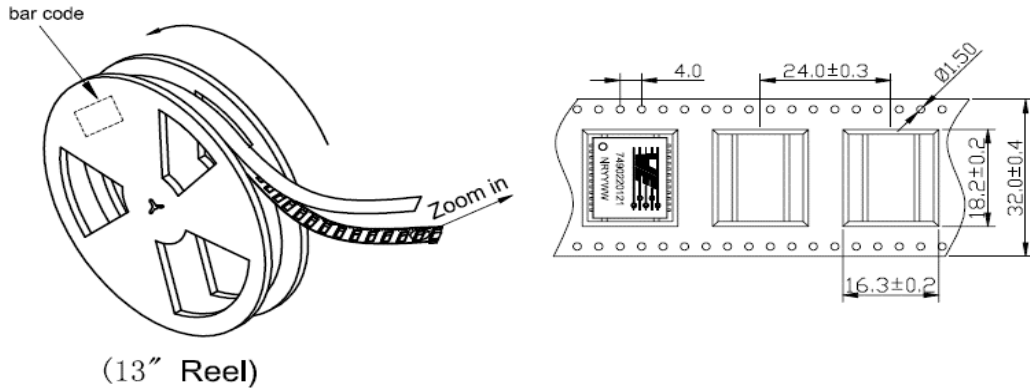

(13" Reel)

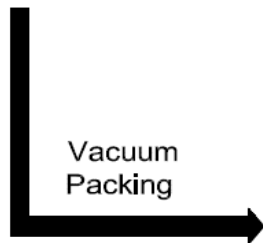

Outside Carton

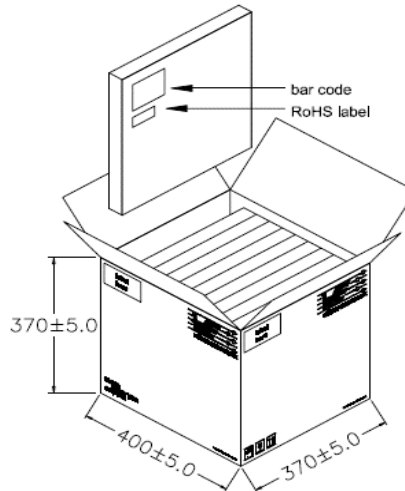

PACKING QUANTITY:

320pcs Finished Goods / Reel

8 Reels (2560pcs Finished Goods) / Carton

Freigabe erteilt / general release:	Kunde / customer			
.....	JaB	Version 04	2018-09-10
Datum / date	Unterschrift / signature	JaB	Version 03	2016-08-09
.....	Würth Elektronik	JaB	Version 02	2016-07-26
.....	JaB	Version 01	2016-04-12
Geprüft / checked	Kontrolliert / approved	JaB	Preliminary	2015-11-06
		Name	Änderung / modification	Datum / date

This electronic component has been designed and developed for usage in general electronic equipment. Before incorporating this component into any equipment where higher safety and reliability is especially required or if there is the possibility of direct damage or injury to human body, for example in the range of aerospace, aviation, nuclear control, submarine, transportation, (automotive control, train control, ship control), transportation signal, disaster prevention, medical, public information network etc, Würth Elektronik eiSos GmbH must be informed before the design-in stage. In addition, sufficient reliability evaluation checks for safety must be performed on every electronic component which is used in electrical circuits that require high safety and reliability functions or performance.

Würth Elektronik eiSos GmbH & Co.KG

D-74638 Waldenburg · Max-Eyth-Straße 1 - 3 · Germany · Telefon (+49) (0) 7942 - 945 - 0 · Telefax (+49) (0) 7942 - 945 - 400
<http://www.we-online.com>