

90584	-**26	26	(35.53)/1.399	(31.75)/1.250	(30.48)/1.200
	-**24	24	(32.99)/1.299	(29.21)/1.150	(27.94)/1.100
	-**22	22	(30.45)/1.199	(26.67)/1.050	(25.40)/1.000
	-**20	20	(27.91)/1.099	(24.13)/.950	(22.86)/.900
	-**18	18	(25.37)/.999	(21.59)/.850	(20.32)/.800
	-**16	16	(22.83)/.899	(19.05)/.750	(17.78)/.700
	-**14	14	(20.29)/.799	(16.51)/.650	(15.24)/.600
	-**12	12	(17.75)/.699	(13.97)/.550	(12.70)/.500
	-**10	10	(15.21)/.599	(11.43)/.450	(10.16)/.400
	-**08	8	(12.67)/.499	(8.89)/.350	(7.62)/.300
	-**06	6	(10.13)/.399	(6.35)/.250	(5.08)/.200
90584	-**04	4	(7.59)/.299	(3.81)/.150	(2.54)/.100
PART NO.	CCT SIZE		DIMENSION A	DIMENSION B	DIMENSION C

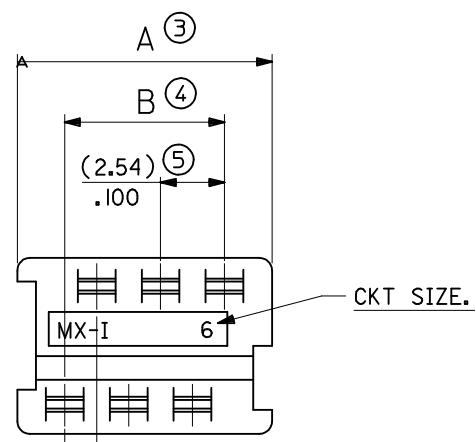

HOUSING
MATL. POLYESTER, RATED UL 94V-0, COLOUR WHITE.

IDT CONTACT
MATL : PHOSPHOR BRONZE (0.28)/.011 REF THICK.
PLATING : (2-4um) / 80-160u" TIN

- NOTES:**
1. APPL. CLASS TO DIN 40040 HME (-25°C/+100°C)
 2. PRODUCT SPECIFICATION: PS-99020-0011
 3. WIRE TERMINATION SPEC: ES-99033-0002
 4. PACKAGING SPEC: PK-90584-001
- 90584- * * * *
- 04 TO 26 = CKT SIZE.
 - 3= NO CIRCUITS VOIDED.
 - 4= CIRCUITS 4 & 5 VOIDED.
 - 1= INDIVIDUAL TUBED ASSY
 - 2= STACKED TUBED ASSY - SEE SHEET 2
 - 8 = NON STANDARD TUBE OPTION - SEE SHEET 3
 - 9= NON STANDARD OPTION - SEE SHEET 3

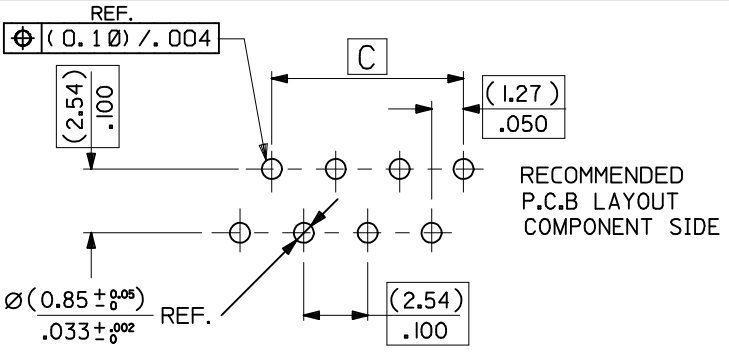
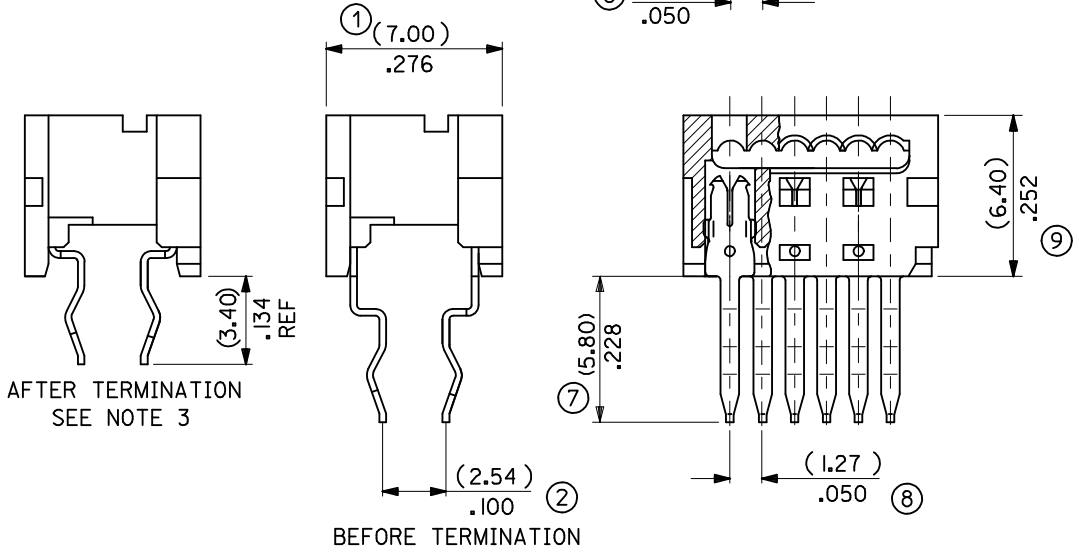

ADDED NON STD TUBE EC NO: IPG2015-0003 DRWN:DBYRNES 2014/07/07 CHKD: APPR:STGRFFIN 2014/10/30 REV DESCRIPTION	QUALITY SYMBOLS ▽=0 ▽=0	GENERAL TOLERANCES (UNLESS SPECIFIED) <table border="1"> <tr> <td></td> <td>mm</td> <td>INCH</td> </tr> <tr> <td>4 PLACES</td> <td>± .---</td> <td>± .---</td> </tr> <tr> <td>3 PLACES</td> <td>± .---</td> <td>± .010</td> </tr> <tr> <td>2 PLACES</td> <td>± 0.25</td> <td>± .---</td> </tr> <tr> <td>1 PLACE</td> <td>± .---</td> <td>± .---</td> </tr> </table>		mm	INCH	4 PLACES	± .---	± .---	3 PLACES	± .---	± .010	2 PLACES	± 0.25	± .---	1 PLACE	± .---	± .---	DIMENSION STYLE MM/IN	SCALE 5:1	DESIGN UNITS METRIC	THIRD ANGLE PROJECTION
		mm	INCH																		
4 PLACES	± .---	± .---																			
3 PLACES	± .---	± .010																			
2 PLACES	± 0.25	± .---																			
1 PLACE	± .---	± .---																			
DRAWN BY: DMCNAR CHECKED BY: BMAGUIRE APPROVED BY: MWILHITE MATERIAL NO. DATE: 2003/09/01	DATE: 2003/09/01 DATE: 2003/09/01 DATE: 2003/09/01	TITLE 1.27MM PF LOW PRO IDT BOARD-IN CONNECTOR	MOLEX INCORPORATED	DOCUMENT NO. SDA-90584	SHEET NO. 1 OF 3	THIS DRAWING CONTAINS INFORMATION THAT IS PROPRIETARY TO MOLEX INCORPORATED AND SHOULD NOT BE USED WITHOUT WRITTEN PERMISSION															

10 9 8 7 6 5 4 3 2 1

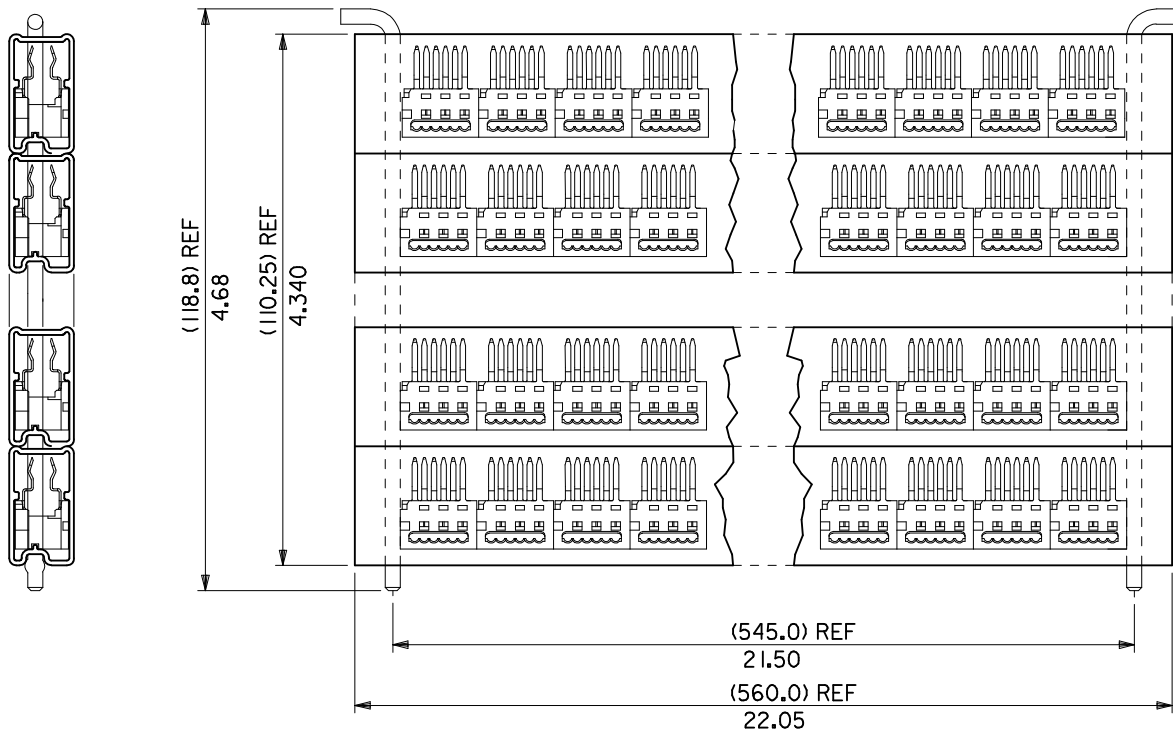

STACKED TUBED ASSEMBLY

REVISION UPDATE EC NO: E2005-1027 DRWN:GMSWEN 2005/05/10 CHK'D:DMOR IARTY 2005/05/10 APPR: JDENNEHY 2005/05/26	QUALITY SYMBOLS ▽=0 ◻=0	GENERAL TOLERANCES (UNLESS SPECIFIED) mm INCH 4 PLACES ± --- ± --- 3 PLACES ± --- ± .010 2 PLACES ± 0.25 ± --- 1 PLACE ± --- ± --- ANGULAR ± 2 °	DIMENSION STYLE MM/IN DRAWN BY PW DATE 1994/02/25 CHECKED BY DMOR IARTY DATE 2005/05/06 APPROVED BY JDENNEHY DATE 2005/05/10	SCALE NTS DESIGN UNITS METRIC THIRD ANGLE PROJECTION	TITLE 1.27MM PF LOW PRO IDT BOARD-IN CONNECTOR
	DRAFT WHERE APPLICABLE MUST REMAIN WITHIN DIMENSIONS	MATERIAL NO. SEE SHEET 1	DOCUMENT NO. SDA-90584	SHEET NO. 2 OF 3	
	SIZE A3	THIS DRAWING CONTAINS INFORMATION THAT IS PROPRIETARY TO MOLEX INCORPORATED AND SHOULD NOT BE USED WITHOUT WRITTEN PERMISSION			
	MOLEX INCORPORATED				

9 8 7 6 5 4 3 2 1

90584-9001	26	(35.53)/ 1.399	(31.75)/ 1.250	(30.48)/ 1.200	12, 13, 14, 15	14	98	7
PART NO.	CCT SIZE	DIMENSION A	DIMENSION B	DIMENSION C	VOIDED POSITIONS	TUBE QTY	STACK QTY	TUBES PER STACK

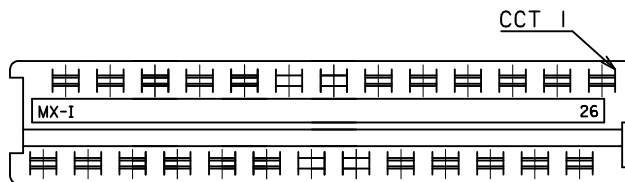

90584-8312	12	(17.75)/.699	(13.97)/.550	(12.70)/.500	27	90	2430
90584-8308	8	(12.67)/.499	(8.89)/.350	(7.62)/.300	38	90	3420
90584-8306	6	(10.13)/.399	(6.35)/.250	(5.08)/.200	48	90	4320
90584-8304	4	(7.59)/.299	(3.81)/.150	(2.54)/.100	64	90	5760
PART No.	CCT SIZE	DIM "A"	DIM "B"	DIM "C"	TUBE QTY	TOTAL TUBES	BOX QTY

NOTES:

- SEE SHEET ONE FOR ALL DIMENSIONS AND NOTES
- 90584-8*** PARTS PACKAGED IN SHORTER TUBE.

NON STANDARD OPTIONS

ADDED TUBE OPTION EC NO: IPG2016-0620 DRWN:DBYRNES 2015/10/23 CHKD: APPR:STGRIFFIN 2015/11/18 REV	QUALITY SYMBOLS	GENERAL TOLERANCES (UNLESS SPECIFIED)	DIMENSION STYLE	SCALE	DESIGN UNITS	THIRD ANGLE PROJECTION	
	▽=0 ▽=0	mm INCH	MM/IN	5:1	METRIC		
		4 PLACES ± --- ± ---	DRAWN BY DATE	TITLE			
		3 PLACES ± --- ± .010	KD 2001/01/31	1.27MM PF LOW PRO IDT BOARD-IN CONNECTOR			
	2 PLACES ± 0.25 ± ---	CHECKED BY DATE	MOLEX INCORPORATED				
	1 PLACE ± --- ± ---	DMORIARTY 2005/05/06	MATERIAL NO. DOCUMENT NO.				
	ANGULAR ± 2 °	APPROVED BY DATE	SDA-90584				
		JDENNEHY 2005/05/10	SEE CHART				
			SHEET NO.				
			3 OF 3				
			THIS DRAWING CONTAINS INFORMATION THAT IS PROPRIETARY TO MOLEX INCORPORATED AND SHOULD NOT BE USED WITHOUT WRITTEN PERMISSION				