

THIS DRAWING IS UNPUBLISHED. RELEASED FOR PUBLICATION
 © COPYRIGHT - By - TE CONNECTIVITY ALL RIGHTS RESERVED.

LOC		DIST		REVISIONS			
P	LTR	DESCRIPTION		DATE	DWN	APVD	
CM	54	V		REVISED PER ECR-20-000826	29MAY2020	PC SW	

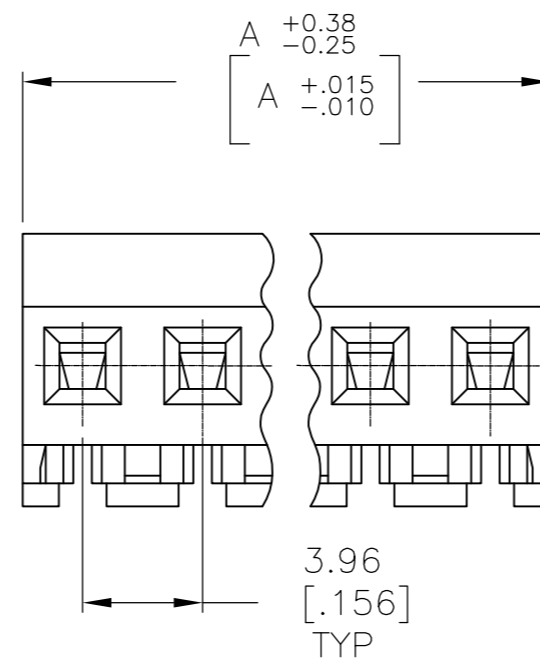
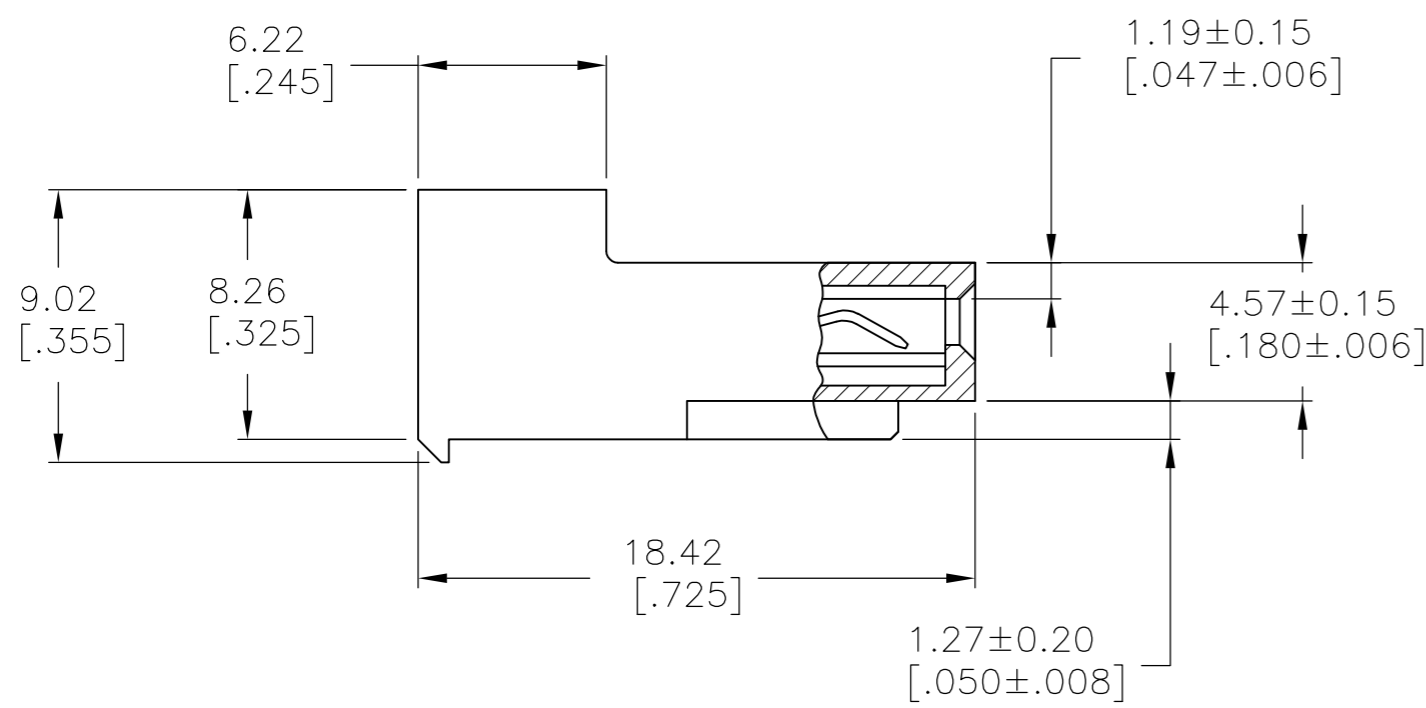
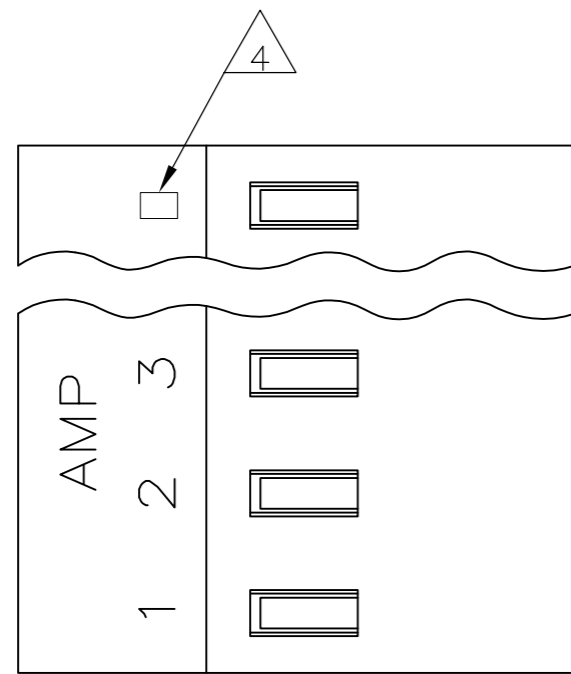

95.10	[3.744]	24	5-640435-4
91.14	[3.588]	23	5-640435-3
87.17	[3.432]	22	5-640435-2
83.21	[3.276]	21	5-640435-1
79.25	[3.120]	20	5-640435-0
75.29	[2.964]	19	4-640435-9
71.32	[2.808]	18	4-640435-8
67.36	[2.652]	17	4-640435-7
63.40	[2.496]	16	4-640435-6
59.44	[2.340]	15	4-640435-5
55.47	[2.184]	14	4-640435-4
51.51	[2.028]	13	4-640435-3
47.55	[1.872]	12	4-640435-2
43.59	[1.716]	11	4-640435-1
39.62	[1.560]	10	4-640435-0
35.66	[1.404]	9	3-640435-9
31.70	[1.248]	8	3-640435-8
27.74	[1.092]	7	3-640435-7
23.77	[.936]	6	3-640435-6
19.81	[.780]	5	3-640435-5
15.85	[.624]	4	3-640435-4
11.89	[.468]	3	3-640435-3
7.92	[.312]	2	3-640435-2

7	SUPERSEDED BY 5-640435-4	95.10	[3.744]	24	2-640435-4
7	SUPERSEDED BY 5-640435-3	91.14	[3.588]	23	2-640435-3
7	SUPERSEDED BY 5-640435-2	87.17	[3.432]	22	2-640435-2
7	SUPERSEDED BY 5-640435-1	83.21	[3.276]	21	2-640435-1
7	SUPERSEDED BY 5-640435-0	79.25	[3.120]	20	2-640435-0
7	SUPERSEDED BY 4-640435-9	75.29	[2.964]	19	1-640435-9
7	SUPERSEDED BY 4-640435-8	71.32	[2.808]	18	1-640435-8
7	SUPERSEDED BY 4-640435-7	67.36	[2.652]	17	1-640435-7
7	SUPERSEDED BY 4-640435-6	63.40	[2.496]	16	1-640435-6
7	SUPERSEDED BY 4-640435-5	59.44	[2.340]	15	1-640435-5
7	SUPERSEDED BY 4-640435-4	55.47	[2.184]	14	1-640435-4
7	SUPERSEDED BY 4-640435-3	51.51	[2.028]	13	1-640435-3
7	SUPERSEDED BY 4-640435-2	47.55	[1.872]	12	1-640435-2
7	SUPERSEDED BY 4-640435-1	43.59	[1.716]	11	1-640435-1
7	SUPERSEDED BY 4-640435-0	39.62	[1.560]	10	1-640435-0
7	SUPERSEDED BY 3-640435-9	35.66	[1.404]	9	640435-9
7	SUPERSEDED BY 3-640435-8	31.70	[1.248]	8	640435-8
7	SUPERSEDED BY 3-640435-7	27.74	[1.092]	7	640435-7
7	SUPERSEDED BY 3-640435-6	23.77	[.936]	6	640435-6
7	SUPERSEDED BY 3-640435-5	19.81	[.780]	5	640435-5
7	SUPERSEDED BY 3-640435-4	15.85	[.624]	4	640435-4
7	SUPERSEDED BY 3-640435-3	11.89	[.468]	3	640435-3
7	SUPERSEDED BY 3-640435-2	7.92	[.312]	2	640435-2

1 MATERIAL: CONNECTOR - NYLON UL94V-2 (BLUE).
 CONTACTS - 0.30[.012] THICK COPPER ALLOY
 BRIGHT TIN-LEAD 0.00203[.000080] MIN THICK
 FOR CONTACT 640435-2 THRU 2-640435-4
 MATTE WHISKER MITIGATED TIN 0.00203[.000080]
 MIN THICKNESS OVER NICKEL UNDERPLATE FOR
 3-640435-2 THRU 5-640435-4

2 CONTACTS ACCEPT 26 AWG WIRE WITH 2.41[.095] MAX INSULATION DIAMETER.

3 CONTACTS MUST ACCEPT 1.14±0.03[.045±.001] SQUARE POST AND REMAIN LOCKED IN POSITION.

4 IDENTIFICATION NUMBER FOR LAST CIRCUIT MAY NOT APPEAR ON ALL ASSEMBLIES.

5 DIMENSIONS IN BRACKETS ARE IN INCHES.

6 HOUSING FEATURES ARE: CLOSED END WITHOUT LOCKING RAMP.

7 OBSOLETE PARTS: OBSOLETE CIS STREAMLINING PER D.RENAUD/D.SINISI\

8 OBSOLETE PARTS

THIS DRAWING IS A CONTROLLED DOCUMENT.		DWN B.LEWIS 12-2-91	TE Connectivity	
DIMENSIONS: mm [INCHES]		CHK R.SWING 12-2-91	NAME	
TOLERANCES UNLESS OTHERWISE SPECIFIED: 0 PLC ± - 1 PLC ± - 2 PLC ± - 3 PLC ± 0.13 [.005] 4 PLC ± - ANGLES ± -		APVD D.CLARK 19-2-91	MTA-156 CONNECTOR ASSEMBLY, 26 AWG, STANDARD	
MATERIAL		PRODUCT SPEC 108-1051	SIZE A2	CAGE CODE 00779
FINISH		APPLICATION SPEC 114-1020	DRAWING NO C-640435	RESTRICTED TO -
CUSTOMER DRAWING		WEIGHT	SCALE 4:1	SHEET 1 OF 1
			REV V	