

PART NAME: STANDOFF

SCALE: 2:1

DATE: 12/9/16

DR. BY: JAM



P/N: SH1006

THIS DRAWING IS THE PROPERTY OF DAVIES MOLDING COMPANY, IS SUBMITTED SOLELY AS A DESIGN OR ENGINEERING PROJECT. WE ACCEPT NO RESPONSIBILITY WHATSOEVER FOR THE PRACTICAL APPLICATION OF THE PIECES MADE TO THIS DESIGN.

ⓑ

DAVIES PART #	THREAD	A	B	C	D
SH1006-A	M5	12	20	8	8
SH1006-B	M5	12	25	8	8
SH1006-C	M5	12	30	8	8
SH1006-D	M5	12	35	8	8
SH1006-E	M5	12	40	8	8
SH1006-F	M5	12	45	8	8
SH1006-G	M5	12	50	8	8
SH1006-H	M5	12	55	8	8
SH1006-J	M5	12	60	8	8
SH1006-K	M5	12	65	8	8
SH1006-L	M5	12	70	8	8
SH1006-M	M5	12	75	8	8
SH1006-N	M5	12	80	8	8
SH1006-P	M5	12	85	8	8
SH1006-Q	M5	12	90	8	8
SH1006-R	M5	12	95	8	8
SH1006-S	M5	12	100	8	8
SH1006-T	M5	12	105	8	8

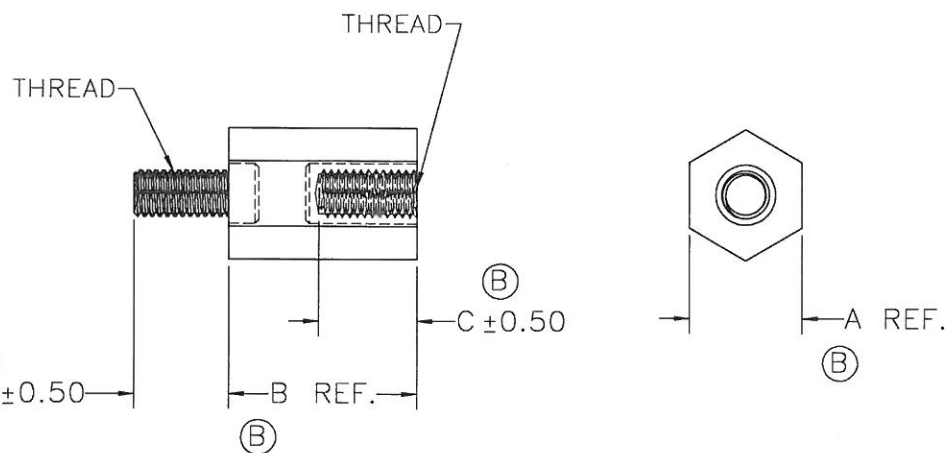

NOTES:

1. OPERATING TEMPERATURE: 125° C
2. INSULATION RESISTANCE: 10000 MOHM @500 V DC
3. DIELECTRIC STRENGTH: 11 KV DC

MATERIAL: NYLON
COLOR: BLACK

STUD: STEEL
INTERNAL INSERT: BRASS

TOLERANCES UNLESS OTHERWISE SPECIFIED				
	B	"C" DIM WAS 9.5, CHANGED TO REF. DIMS.	JAM	5/10/22
	A	UPDATED TABLE	JAM	10/11/18
CHANGES				