

PAGE 1/2	ISSUE 15-05-15G	SERIES QMA	PART NUMBER R123071000
----------	-----------------	-------------------	-------------------------------

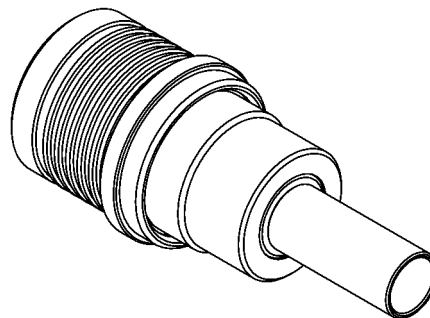

All dimensions are in mm.

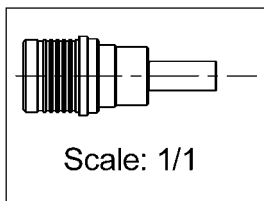
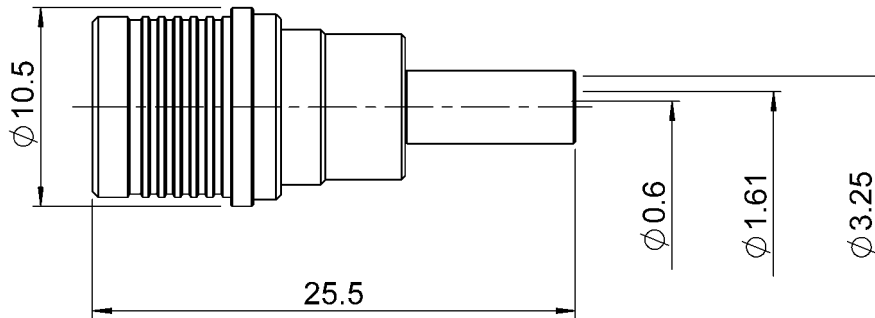
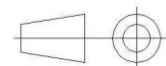

COMPONENTS	MATERIALS	PLATING (µm)
Body	BRASS	BBR
Center contact	BRASS	NPGR
Outer contact	BRONZE	BBR
Insulator	PTFE	
Gasket	-	
Others parts	BRASS	BBR
-	-	-
-	-	-

PAGE 2/2	ISSUE 15-05-15G	SERIES QMA	PART NUMBER R123071000
----------	-----------------	------------	------------------------

PACKAGING

Standard	Unit	Other
100	Contact us	Contact us

ELECTRICAL CHARACTERISTICS

Impedance	50	Ω
Frequency	0-6	GHz
VSWR	+ 0.0000	x F(GHz) Maxi
Insertion loss	.05	\sqrt{F} (GHz) dB Maxi
RF leakage	- (80	- F(GHz)) dB Maxi
Voltage rating	250	Veff Maxi
Dielectric withstanding voltage	750	Veff mini
Insulation resistance	5000	M Ω mini

MECHANICAL CHARACTERISTICS

Center contact retention		
Axial force – Mating End	18	N mini
Axial force – Opposite end	18	N mini
Torque	NA	N.cm mini
Recommended torque		
Mating	NA	N.cm
Panel nut	NA	N.cm
Clamp nut	NA	N.cm
A/F clamp nut	0.0000	mm
Mating life	100	Cycles mini
Weight	5.7550	g

ENVIRONMENTAL

Operating temperature	-40/+105	$^{\circ}\text{C}$
Hermetic seal	NA	Atm.cm3/s
Panel leakage	NA	

SPECIFICATION

CABLE ASSEMBLY

Stripping	a	b	c	d	e	f
mm	3	6.3	10.8	0	7.8	0

Assembly instruction: **Crimp 02**

Recommended cable(s)

RG 188
RG 316
KX 22A

Characteristics indicated on this data sheet are those that can be achieved with the highest performance cable. Intrinsic limitations of the cable may diminish the performance of the assembly

Cable retention

- pull off	90	N mini
- torque	NA	N.cm

TOOLING

Part Number	Description	Hexagon
R282211000	CRIMPING TOOL	3.25
R282235003	CRIMPING DIES M22520/5-03	3.25
R282281000	CRIMPING TOOL	2x4 (pos. 5)
R282293000	CRIMPING TOOL M22520/5-01	
R282967015	POSITIONER FOR CRIMPING TOOL	
R299511016	STRIPPING CASSETTE .059/.248	denudage B, E

OTHER CHARACTERISTICS

VSWR : 1.12 max from 0 to 3GHz
Intermod.: -120 dBc at 1.8GHz (2x20W)
RF leakage(interf.): 3<F<6GHz: >70dB