

# **UCC28063EVM-723 300-W Interleaved PFC Pre-Regulator**

The UCC28063 is a dual-phase, transition-mode Power Factor Correction (PFC) pre-regulator. The UCC28063EVM-723 is an evaluation module (EVM) with a 390-V, 300-W, dc output that operates from a universal input of 85 V<sub>RMS</sub> to 265 V<sub>RMS</sub> and provides power-factor correction.

Throughout this document, the acronym *EVM* and the phrases *evaluation board* and *evaluation module* are synonymous with the UCC28063EVM.

## **1 Description**

The pre-regulator uses the [UCC28063 PFC interleaved controller](#) to shape the input current wave to provide power-factor correction. This device uses TI's *Natural Interleaving*<sup>™</sup> technology to interleave boost phases.

This user's guide provides the schematic, List of Materials, assembly drawing for a single-sided printed circuit board application, and test set-up information necessary to evaluate the UCC28063 in a typical PFC application.

## **2 Thermal Requirements**

This evaluation module will operate up to 300 W without external cooling in ambient temperatures of 25°C.

## **3 Electrical Characteristics**

[Table 1](#) summarizes the electrical specifications of the UCC28063EVM-723.

**Table 1. UCC28063EVM-723 Electrical Specifications**

PARAMETER	CONDITIONS	UCC28063EVM			UNITS
		MIN	TYP	MAX	
RMS input voltage (ac line)		85		265	V <sub>RMS</sub>
Output voltage, V <sub>OUT</sub>			390		V
Line frequency		47		63	Hz
Power factor (PF) at maximum load		0.9			
Output power				300	W
Full load efficiency	AC line = 115 V		94%		
	AC line = 230 V		97%		

*Natural Interleaving* is a trademark of Texas Instruments.  
 All other trademarks are the property of their respective owners.

4 Schematics

Figure 1 and Figure 2 show the schematics for this EVM. See the List of Materials for specific values.

To evaluate inductor ripple currents, resistors R25 and R26 can be removed and replaced with current loops.

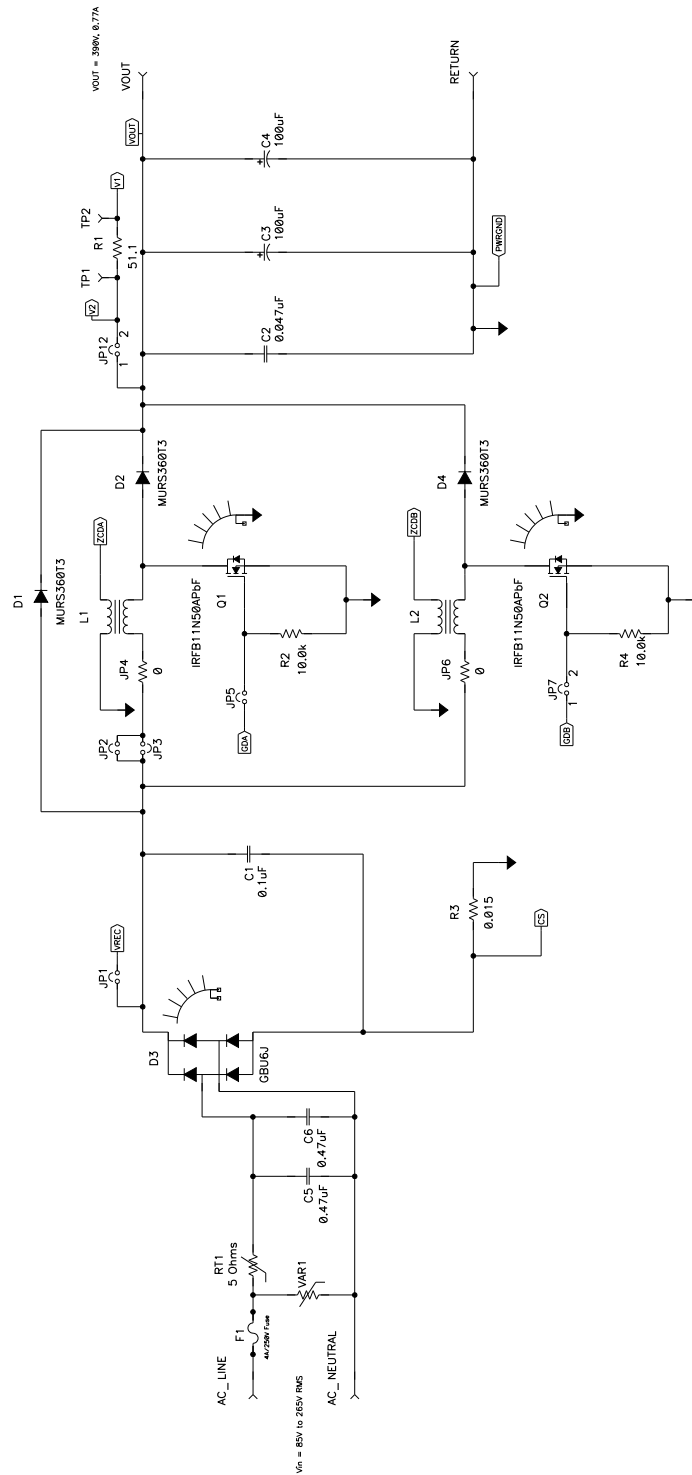

Figure 1. Interleaved PFC Power Stage

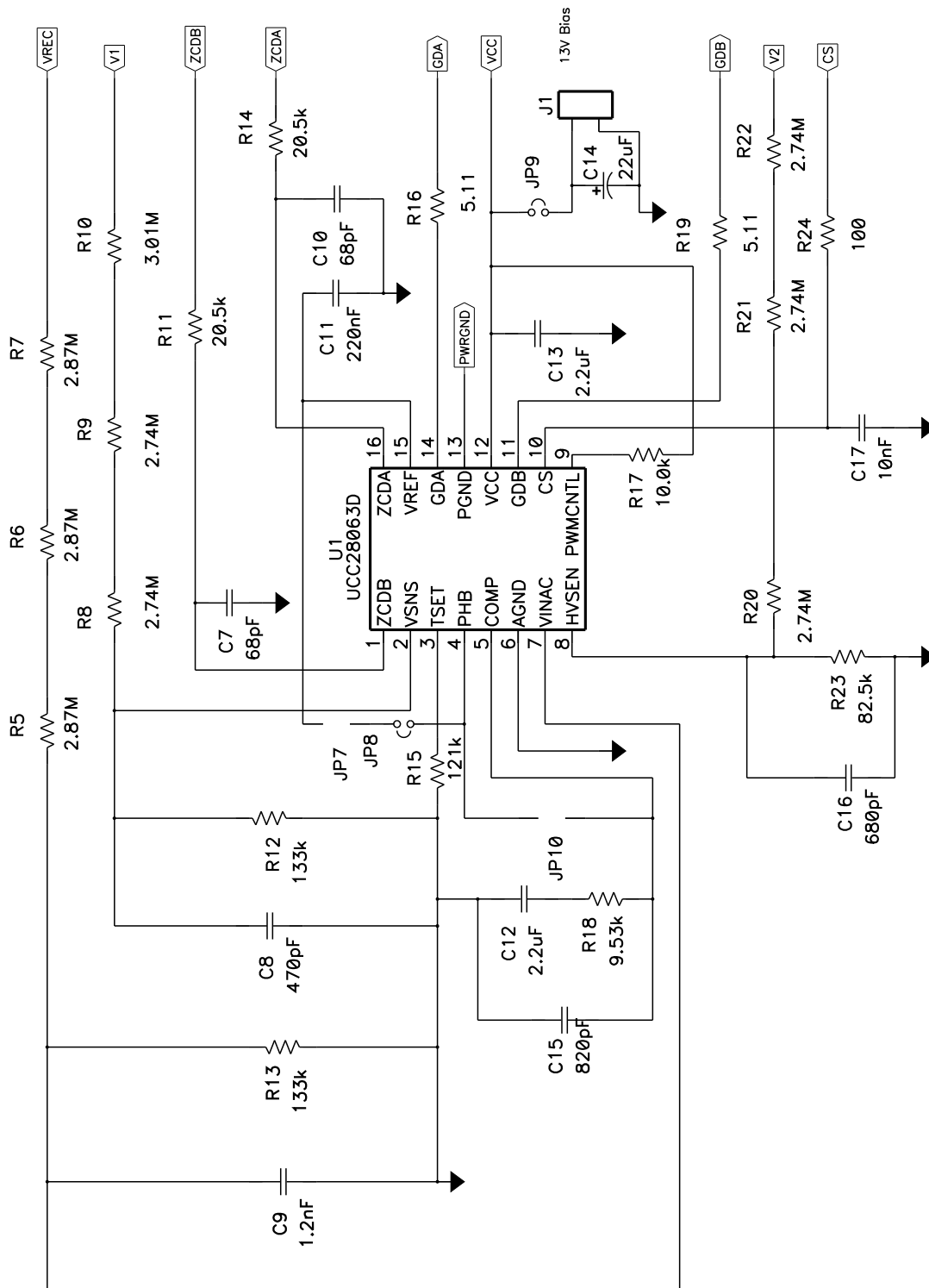

Figure 2. Controller Circuitry

## 5 Test Setup and Power-Up/Power-Down Instructions

### **WARNING**

There are high voltages present on the pre-regulator. It should only be handled by experienced power supply professionals. To evaluate this board as safely as possible, the following test configuration should be used:

- Connect an isolation transformer between the source and unit
- Attach a voltmeter and a resistive or electronic load to the unit output **before** supplying power to the EVM.

A separate 13-V bias supply is required to power the UCC28063 control circuitry. The unit will start up under no-load conditions. However, for safety, a load should be connected to the output of the device before it is powered up. The unit should also never be handled while power is applied to it or when the output voltage is above 50-V dc. Refer to [Figure 3](#) for a recommended test setup diagram.

### **CAUTION**

There are very high voltages on the board. Components can and will reach temperatures greater than 100°C. Use caution when handling the EVM.

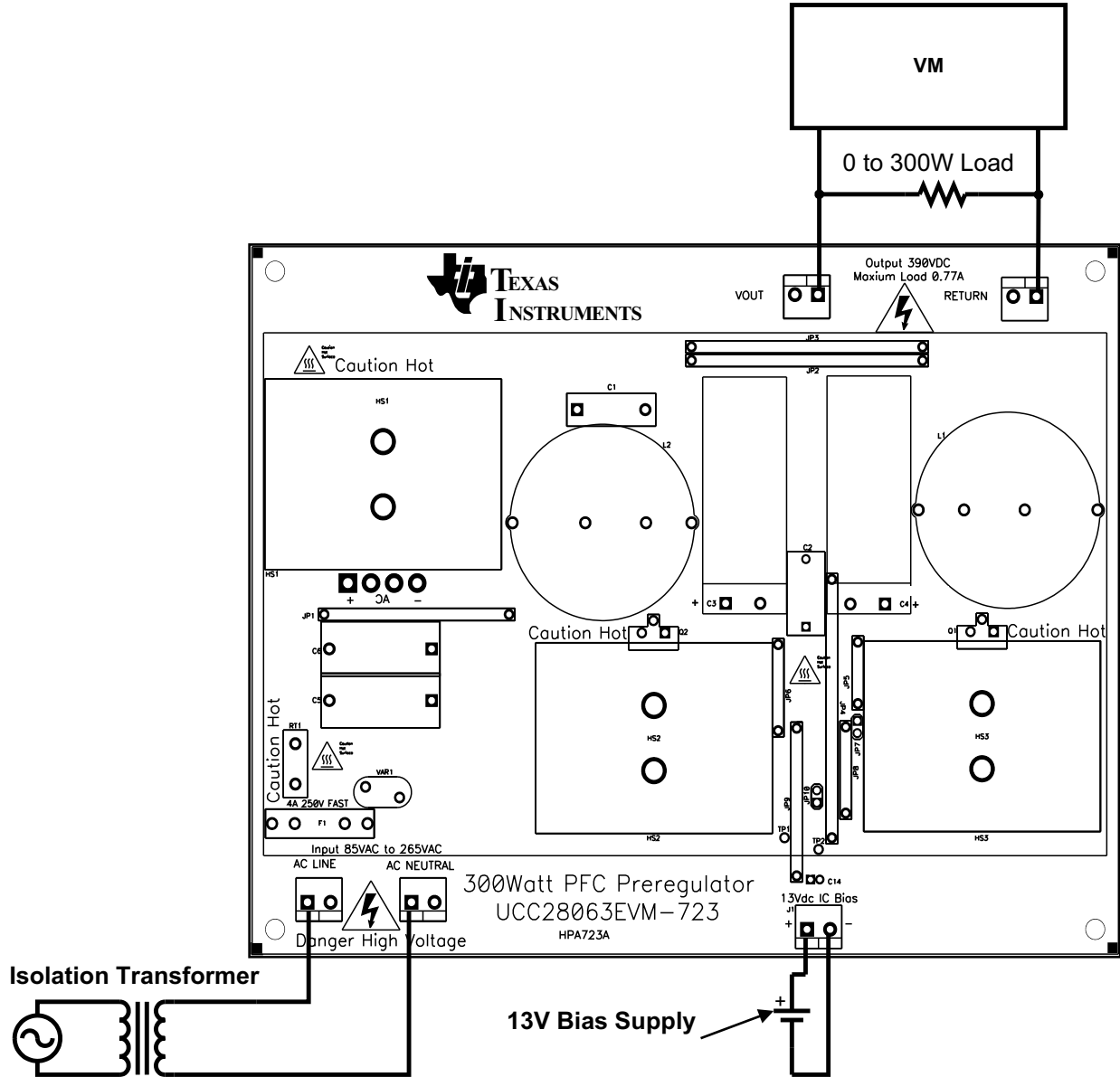

Figure 3. Test Setup

## 6 Typical Performance Data

Figure 4 through Figure 7 present characteristic performance data for the UCC28063EVM-723.

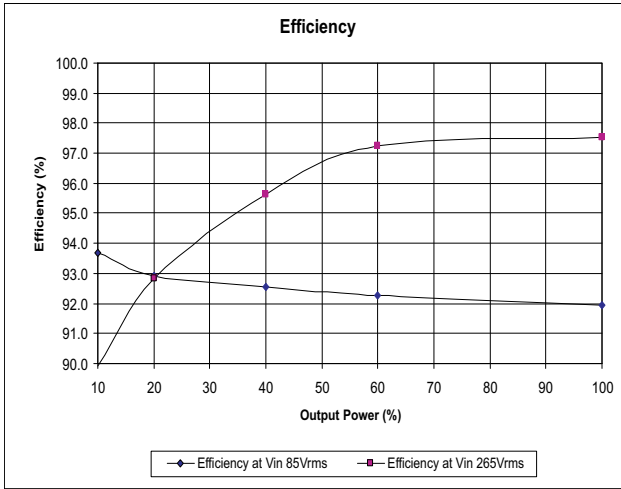

Figure 4. Efficiency at 85 V<sub>RMS</sub> and 265 V<sub>RMS</sub>

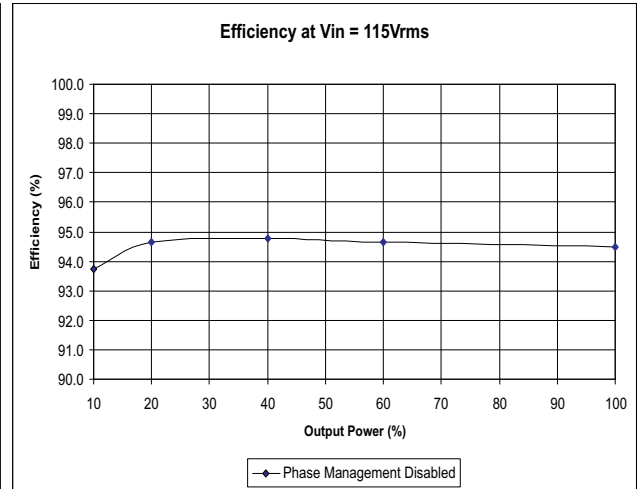

Figure 5. Efficiency at 115 V<sub>RMS</sub>, Without Phase Management

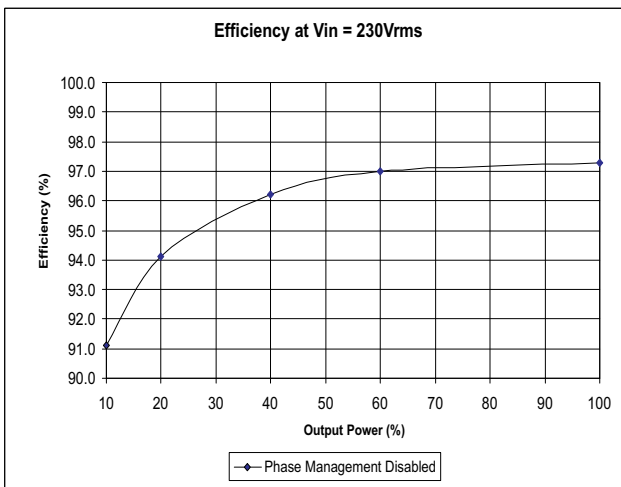

Figure 6. Efficiency at 230 V<sub>RMS</sub>, Without Phase Management

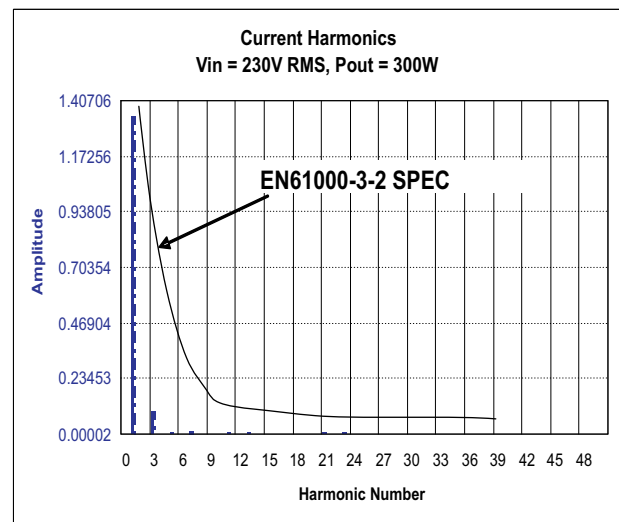

Figure 7. Current Harmonics

### 6.1 Output Ripple Voltage at Full Load

Figure 8 illustrates the output ripple voltage.

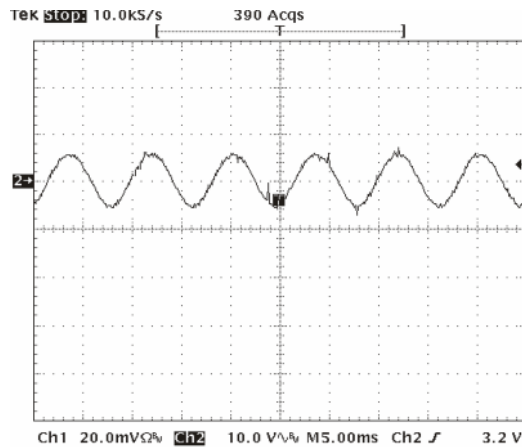

Figure 8.  $V_{OUT}$  Ripple,  $P_{OUT} = 300\text{ W}$

### 6.2 Input Ripple Current Cancellation

Figure 9 through Figure 14 show the input current ( $M_1 = I_{L1} + I_{L2}$ ), Inductor Ripple Current ( $I_{L1}$ ,  $I_{L2}$ ) versus rectified line voltage. From these graphs, it can be observed that interleaving reduces the magnitude of input ripple current caused by the inductor ripple current.

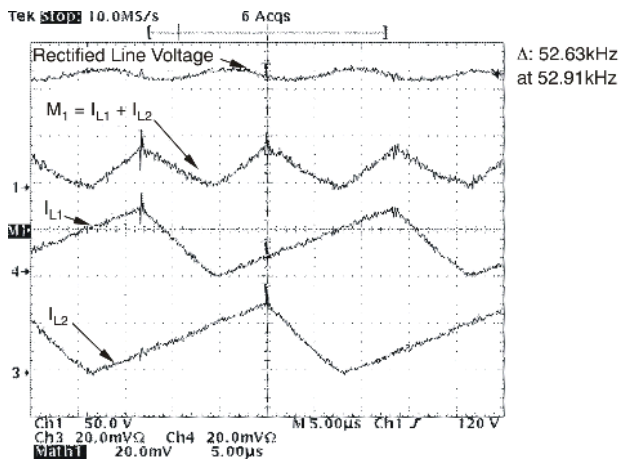

Figure 9. Inductor and Input Ripple Current at  $85\text{ V}_{RMS}$  at Peak of Line Voltage

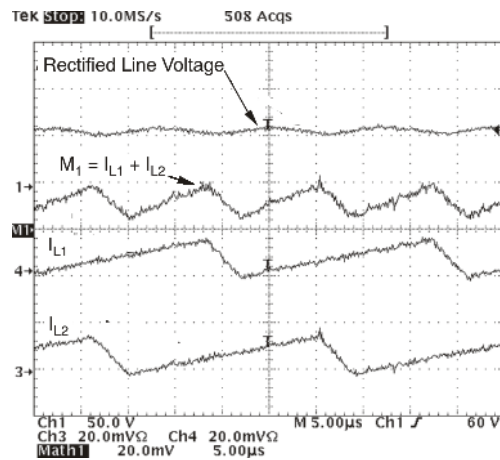

Figure 10. Inductor and Input Ripple Current at  $85\text{ V}_{RMS}$  Input at Half the Line Voltage

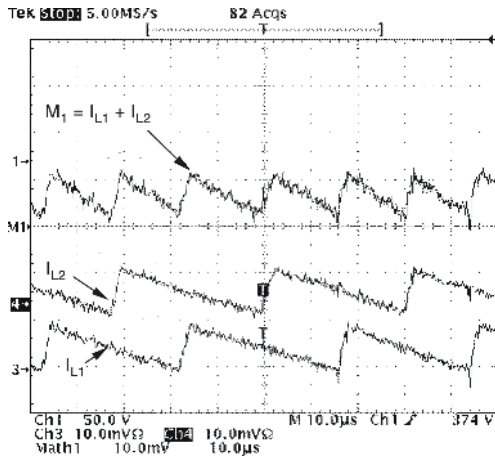

Figure 11. Inductor and Input Ripple Current at 265  $V_{RMS}$  Input at Peak Line Voltage

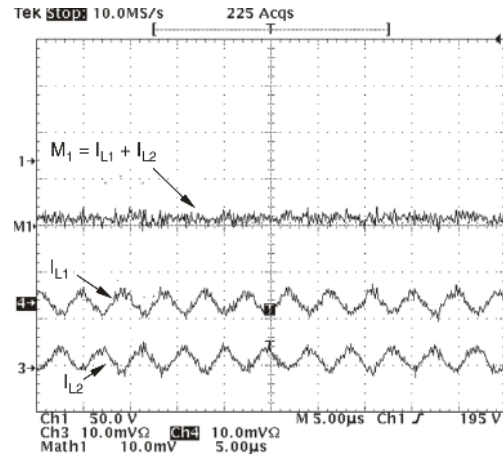

Figure 12. Inductor and Input Ripple Current at 265  $V_{RMS}$  Input at Half Peak Line Voltage

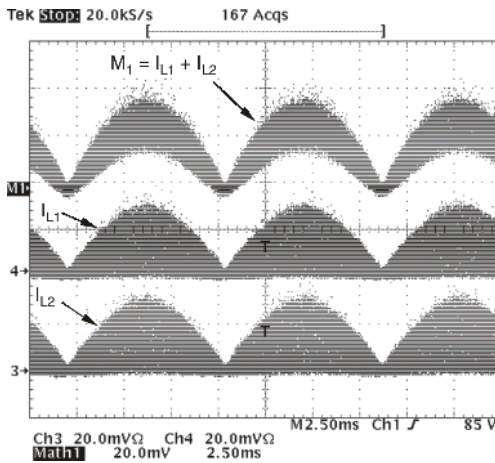

Figure 13. Inductor and Input Ripple Current at  $V_{IN} = 85 V_{RMS}$ ,  $P_{OUT} = 300 W$

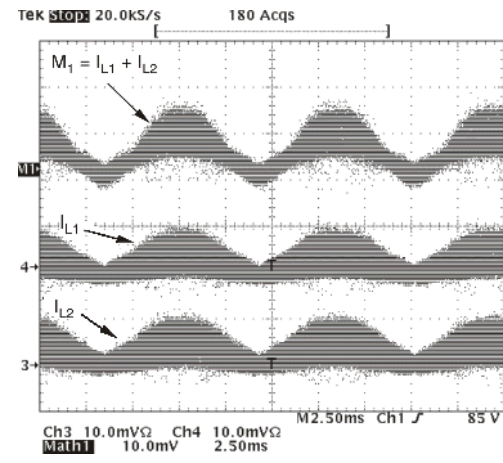

Figure 14. Inductor and Input Ripple Current at  $V_{IN} = 265 V_{RMS}$ ,  $P_{OUT} = 300 W$



### 6.3 Startup Characteristics

Figure 15 and Figure 16 illustrate the UCC28063EVM-723 startup characteristics.

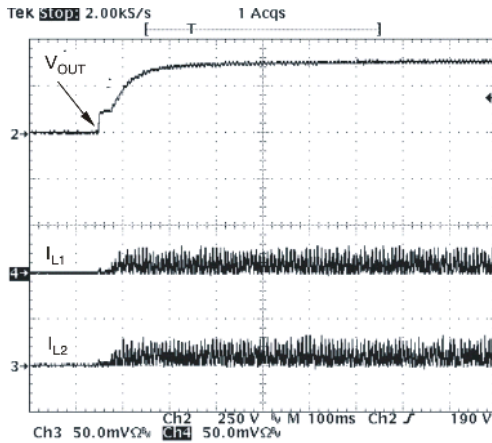

Figure 15. Start-Up at  $V_{IN} = 85 V_{RMS}$ ,  $P_{OUT} = 300 W$

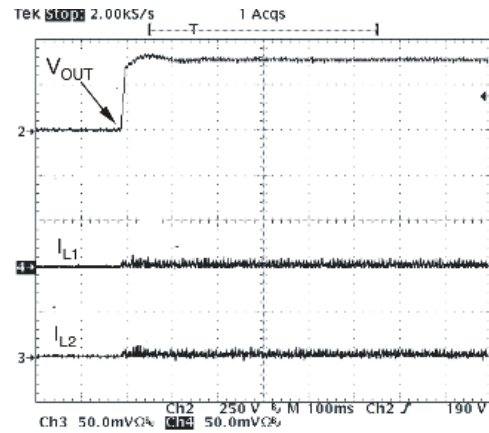

Figure 16. Start-Up at  $V_{IN} = 265 V_{RMS}$ ,  $P_{OUT} = 0 W$

### 6.4 Brownout Protection

The UCC28063 has a brownout protection that shuts down both gate drives (GDA and GDB) when the VINAC pin detects that the RMS input voltage is too low. This EVM was designed to go into a brownout state when the line drops below  $64 V_{RMS}$ . Once the UCC28063 control device has determined that the input is in a brownout condition, a 400-ms timer starts to allow the line to recover before shutting down the gate drivers. After 400 ms of brownout, both gate drivers turn off, as shown in Figure 17 and Figure 18.

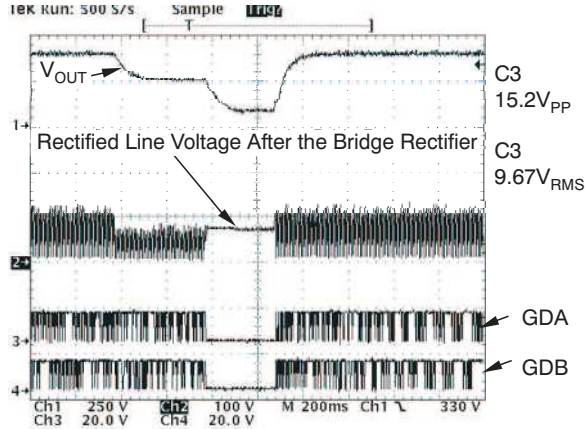

Figure 17. Brownout at  $85 V_{RMS}$

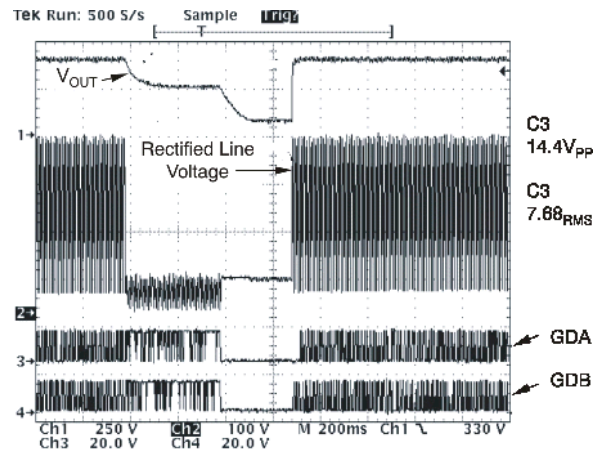

Figure 18. Brownout at  $265 V_{RMS}$

### 6.5 Line Transient

A line transient test was conducted with an ac source on the reference design. The line was varied from 230 V<sub>RMS</sub> to 115 V<sub>RMS</sub> to 230 V<sub>RMS</sub> and the transient response was evaluated in each case. From the oscilloscope image in Figure 19, it can be observed that the output recovered from line transients within 300ms at full load.

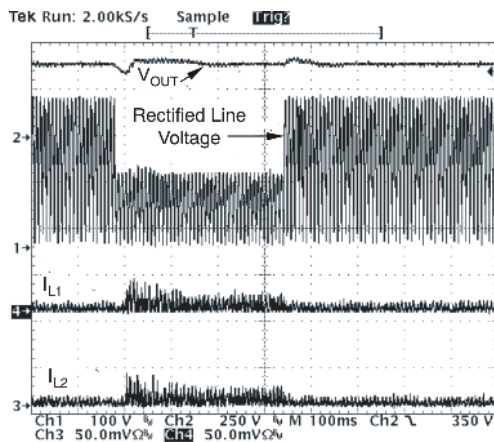

Figure 19. Line Transient, P<sub>OUT</sub> = 300W

## 7 Reference Design Assembly Drawing

Figure 20 and Figure 22 show the top and bottom layers (respectively) of the UCC28063EVM-723.

**NOTE:** Board layouts are not to scale. These figures are intended to show how the board is laid out; they are not intended to be used for manufacturing UCC28063EVM-723 PCBs.

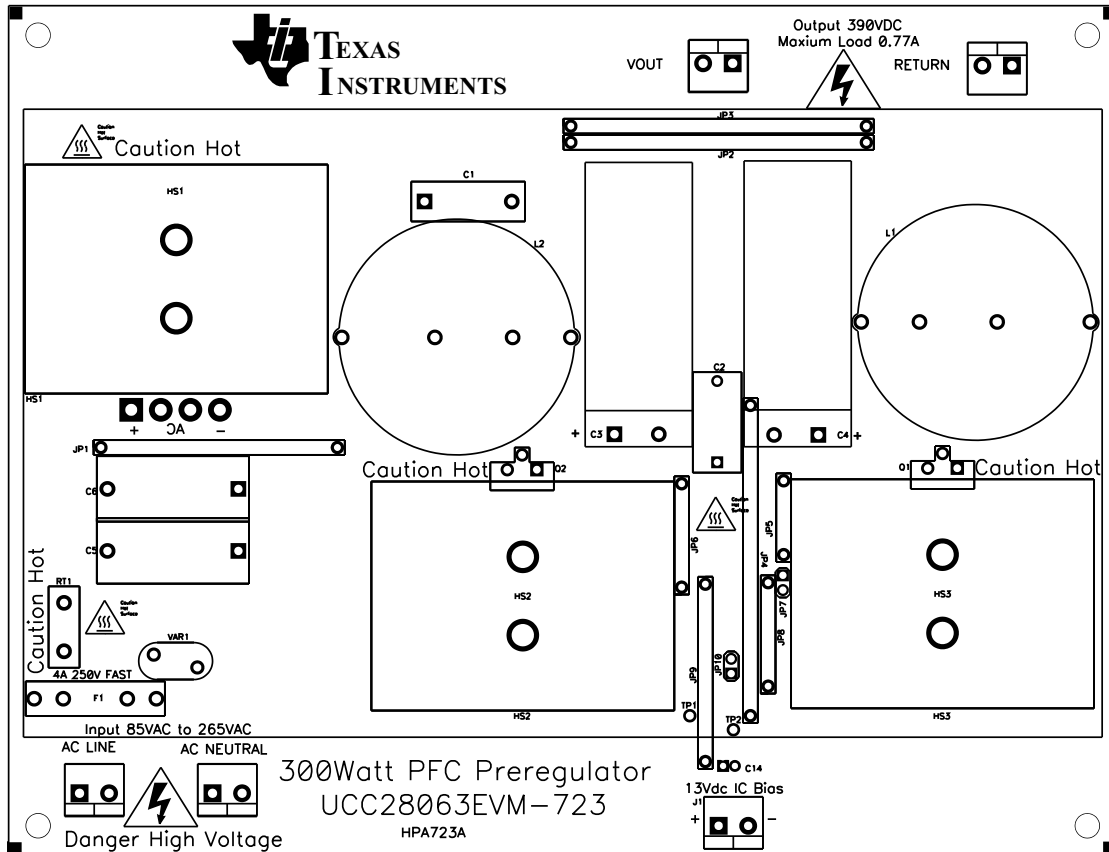

Figure 20. Top Layer Assembly

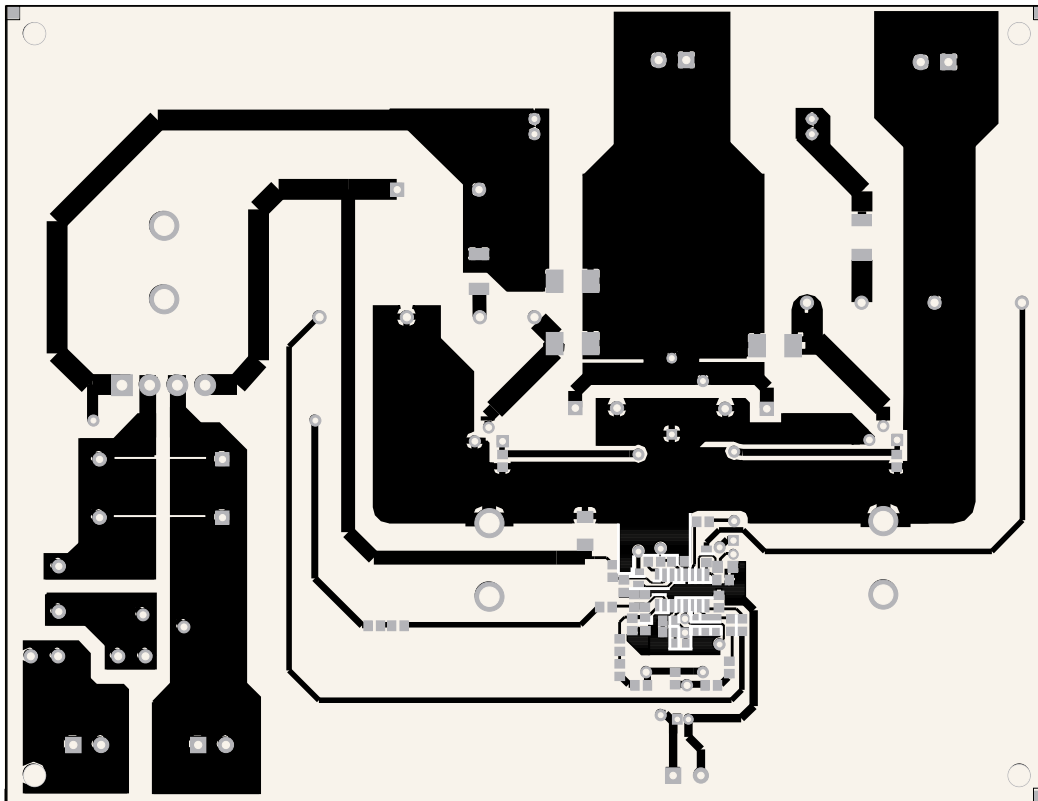
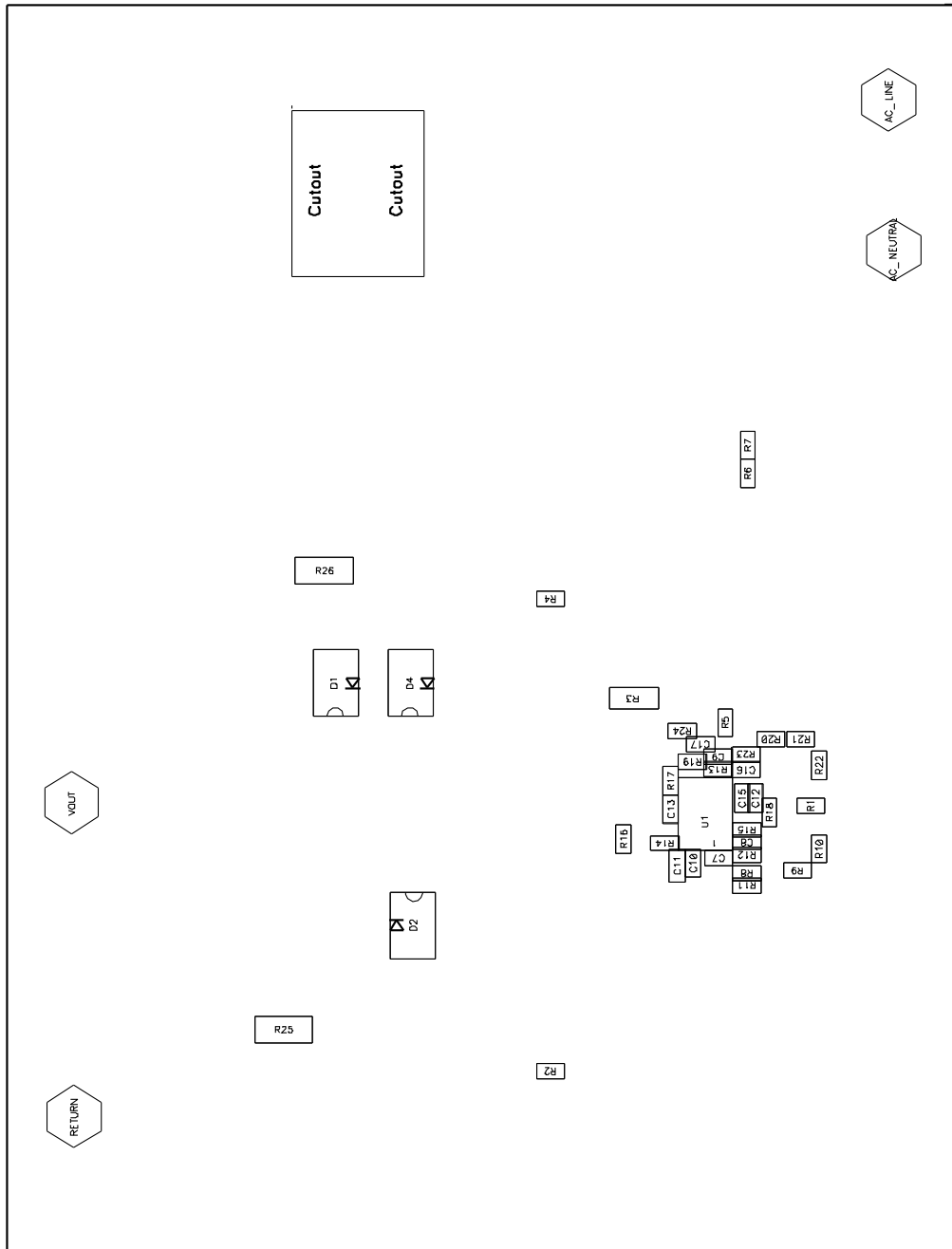

Figure 21. Bottom Layer Copper



**Figure 22. Bottom Layer Assembly**

## 8 List of Materials

Table 2 lists the EVM components as configured according to the schematics (see Section 4).

**Table 2. List of Materials**

COUNT	REF DES	DESCRIPTION	PART NUMBER	MFR
4	AC_LINE, AC_NEUTRAL, RETURN, VOUT	Terminal block, 2 pin, 15 A, 5.1 mm	ED120/2DS	OST
1	C1	Capacitor, film, 275VAC, 20±%, 0.1 µF, 0.689 x 0.236 inch	ECQU2A104BC1	Panasonic
1	C11	Capacitor, ceramic, 16 V, X7R, 10%, 220 nF, 1206	Std	Std
2	C12, C13	Capacitor, ceramic, 16 V, X7R, 10%, 2.2 µF, 0805	Std	Std
1	C14	Capacitor, aluminum, 35 V, ±20%, 22 µF, 0.200 * 0.435 inch	ECA-1VM220	Panasonic
1	C15	Capacitor, ceramic, 25 V, X7R, 10%, 820 pF, 0805	Std	Std
1	C17	Capacitor, ceramic, 25 V, X7R, 10%, 10 nF, 0805	Std	Std
1	C2	Capacitor, polyester, 630 V, 10%, 0.047 µF, 0.256 x 0.650 inch	ECQ-E6473KZ	Panasonic
2	C3, C4	Capacitor, aluminum, 450 VDC, ±20% , 100 µF, 18 x 40 mm	EKXG451ELL101 MM40S	Nippon Chemi-con
2	C5, C6	Capacitor, film, 275 VAC, 20±%, 0.47 µF, 0.236 X 0.591	ECQ-U2A474MG	Panasonic
2	C7, C10	Capacitor, ceramic, 25 V, X7R, 10%, 22 pF, 0805	Std	Std
3	C8, C9, C16	Capacitor, ceramic, 25 V, X7R, 10%, 1.2 nF, 0805	Std	Std
3	D1, D2, D4	Diode, 3000 mA, 600 V, SMC	MURS360T3	On Semi
1	D3	Diode, bridge, 6 A, 600 V, BU6	GBU6J	Vishay
2	F1	Fuse clip, 5x20 mm	0100056H	Wickmann
3	HS1, HS2, HS3	Heatsink, universal-mount TO-220, 7-345-2PP, 1.500 x 2.000 inch	7-345-2PP	IERC-CTS
1	J1	Terminal block, 2 pin, 15 A, 5.1 mm, ED1609-ND, 0.40 x 0.35 inch	ED1609	OST
3	JP1, JP2, JP3	Jumper, 2.000 inch length, PVC insulation, AWG 22, 0.035 inch dia.	923345-20-C	3M
1	JP4	Jumper, 2.100 inch length, PVC insulation, AWG 22, 0.035 inch dia.	923345-21-C	3M
1	JP5	Jumper, 0.500 inch length, PVC insulation, AWG 22, 0.035 inch dia	923345-05-C	3M
2	JP6, JP8	Jumper, 0.700 inch length, PVC insulation, AWG 22	923345-07-C	3M
1	JP7	Jumper, 0.100 inch length, non-insulated, AWG 22	923345-01-C	3M
1	JP10	Header, 2-pin, 100-mil spacing, 0.100 inch x 2	PEC02SAAN	Sullins
1	JP9	Jumper, 1.2 inch length, PVC insulation, AWG 22, 0.035 inch dia.	923345-20-C	3M
2	L1, L2**	Inductor, boost PFC with aux. 330 uH @ 5.3 A PK, 1.555 Dia. inch	CTX16-17769R	Cooper
2	Q1, Q2	MOSFET, N-channel, 500 V, 11 A, 520 mΩ, TO-220V	IRFB11N50APbF	IR

**Table 2. List of Materials (continued)**

COUNT	REF DES	DESCRIPTION	PART NUMBER	MFR
1	R1	Resistor, chip, 1/10 W, 1%, 51.1 $\Omega$ , 0805	Std	Std
2	R11, R14	Resistor, chip, 1/10 W, 1%, 20.5 k $\Omega$ , 0805	Std	Std
2	R12, R13	Resistor, chip, 1/10 W, 1%, 133 k $\Omega$ , 0805	Std	Std
1	R15	Resistor, chip, 1/10 W, 1%, 121 k $\Omega$ , 0805	Std	Std
2	R16, R19	Resistor, chip, 1/10 W, 1%, 5.11 $\Omega$ , 0805	Std	Std
1	R18	Resistor, chip, 1/10 W, 1%, 9.53 k $\Omega$ , 0805	Std	Std
3	R2, R4, R17	Resistor, chip, 1/10 W, 1%, 10.0 k $\Omega$ , 0805	Std	Std
1	R23	Resistor, chip, 1/10 W, 1%, 82.5 k $\Omega$ , 0805	Std	Std
1	R24	Resistor, chip, 1/10 W, 1%, 100 $\Omega$ , 0805	Std	Std
2	R25, R26	Resistor, chip, 1 W, 5%, 0 $\Omega$ , 2512	Std	Std
1	R3	Resistor, chip, 1/2 W, 1%, 0.015 $\Omega$ , 2010	WSL2010R0150F EA	Vishay
3	R5, R6, R7	Resistor, Chip, 1/10 W, 1%, 2.87 M $\Omega$	Std	Std
5	R8, R9, R20, R21, R22	Resistor, chip, 1/10 W, 1%, 2.74 M $\Omega$ , 0805	Std	Std
1	R10	Resistor, Chip, 1/10 W, 1%, 3.01 M $\Omega$ , 0805	Std	Std
1	RT1	Thermistor, NTC, 5 $\Omega$ , 6 A, 5 $\Omega$ , 0.180 X 0.550 inch	CL-40	Thermometrics
2	TP1, TP2	Pin, thru hole, tin plate, for 0.062 PCB's, K24A/M, 0.039 inch	K24A/M	Vector
1	U1	Interleave PFC Controller, SO16	UCC28063D	TI
1	VAR1	Varistor 275 V RMS, 0.472 x 0.213 inch	S10K275E2	Epcos
1	PCB	HPA343 printed circuit board	HPA343	
1	X1 @ F1	4 A, fast acting fuse, BK/GDA-4A, 5mmX20mm	BK/S501-4-R	Cooper/Bussman
6	"X1 @ HS1 and D3, HS2 and Q1, HS3 and Q2"	Nut #4-40 (steel)	Std	Std
6	"X1 @ HS1 and D3, HS2 and Q1, HS3 and Q2"	Pan head screw #4-40X3/8 (steel)	Std	Std
1	X1 D3 and HS1	Thermal grease	Std	Std
6	"X1 @ HS1 and D3, HS2 and Q1, HS3 and Q2"	Split lock washer #4(steel)	Std	Std
6	"X1 @ HS1 and D3, HS2 and Q1, HS3 and Q2"	Nylon shoulder washer #4	3049	Keystone Electronics
2	"X1 @ HS2 and Q1, HS3 and Q2"	Thermal pad silicon TO220	3223-07FR-51	BERQUIST
4	1903C	Standoff hex .500/6-32THR nylon	1903C	Keystone Electronics
4	4824	Nut	4824	Keystone Electronics

## Evaluation Board/Kit Important Notice

Texas Instruments (TI) provides the enclosed product(s) under the following conditions:

This evaluation board/kit is intended for use for **ENGINEERING DEVELOPMENT, DEMONSTRATION, OR EVALUATION PURPOSES ONLY** and is not considered by TI to be a finished end-product fit for general consumer use. Persons handling the product(s) must have electronics training and observe good engineering practice standards. As such, the goods being provided are not intended to be complete in terms of required design-, marketing-, and/or manufacturing-related protective considerations, including product safety and environmental measures typically found in end products that incorporate such semiconductor components or circuit boards. This evaluation board/kit does not fall within the scope of the European Union directives regarding electromagnetic compatibility, restricted substances (RoHS), recycling (WEEE), FCC, CE or UL, and therefore may not meet the technical requirements of these directives or other related directives.

Should this evaluation board/kit not meet the specifications indicated in the User's Guide, the board/kit may be returned within 30 days from the date of delivery for a full refund. **THE FOREGOING WARRANTY IS THE EXCLUSIVE WARRANTY MADE BY SELLER TO BUYER AND IS IN LIEU OF ALL OTHER WARRANTIES, EXPRESSED, IMPLIED, OR STATUTORY, INCLUDING ANY WARRANTY OF MERCHANTABILITY OR FITNESS FOR ANY PARTICULAR PURPOSE.**

The user assumes all responsibility and liability for proper and safe handling of the goods. Further, the user indemnifies TI from all claims arising from the handling or use of the goods. Due to the open construction of the product, it is the user's responsibility to take any and all appropriate precautions with regard to electrostatic discharge.

**EXCEPT TO THE EXTENT OF THE INDEMNITY SET FORTH ABOVE, NEITHER PARTY SHALL BE LIABLE TO THE OTHER FOR ANY INDIRECT, SPECIAL, INCIDENTAL, OR CONSEQUENTIAL DAMAGES.**

TI currently deals with a variety of customers for products, and therefore our arrangement with the user **is not exclusive.**

TI assumes **no liability for applications assistance, customer product design, software performance, or infringement of patents or services described herein.**

Please read the User's Guide and, specifically, the Warnings and Restrictions notice in the User's Guide prior to handling the product. This notice contains important safety information about temperatures and voltages. For additional information on TI's environmental and/or safety programs, please contact the TI application engineer or visit [www.ti.com/esh](http://www.ti.com/esh).

No license is granted under any patent right or other intellectual property right of TI covering or relating to any machine, process, or combination in which such TI products or services might be or are used.

## FCC Warning

This evaluation board/kit is intended for use for **ENGINEERING DEVELOPMENT, DEMONSTRATION, OR EVALUATION PURPOSES ONLY** and is not considered by TI to be a finished end-product fit for general consumer use. It generates, uses, and can radiate radio frequency energy and has not been tested for compliance with the limits of computing devices pursuant to part 15 of FCC rules, which are designed to provide reasonable protection against radio frequency interference. Operation of this equipment in other environments may cause interference with radio communications, in which case the user at his own expense will be required to take whatever measures may be required to correct this interference.

## EVM Warnings and Restrictions

It is important to operate this EVM within the input voltage range of xxx V to xxx V and the output voltage range of xxx V to xxx V . Exceeding the specified input range may cause unexpected operation and/or irreversible damage to the EVM. If there are questions concerning the input range, please contact a TI field representative prior to connecting the input power.

Applying loads outside of the specified output range may result in unintended operation and/or possible permanent damage to the EVM. Please consult the EVM User's Guide prior to connecting any load to the EVM output. If there is uncertainty as to the load specification, please contact a TI field representative.

During normal operation, some circuit components may have case temperatures greater than xxx° C. The EVM is designed to operate properly with certain components above xxx° C as long as the input and output ranges are maintained. These components include but are not limited to linear regulators, switching transistors, pass transistors, and current sense resistors. These types of devices can be identified using the EVM schematic located in the EVM User's Guide. When placing measurement probes near these devices during operation, please be aware that these devices may be very warm to the touch.

Mailing Address: Texas Instruments, Post Office Box 655303, Dallas, Texas 75265  
Copyright © 2011, Texas Instruments Incorporated



## EVALUATION BOARD/KIT/MODULE (EVM) ADDITIONAL TERMS

Texas Instruments (TI) provides the enclosed Evaluation Board/Kit/Module (EVM) under the following conditions:

The user assumes all responsibility and liability for proper and safe handling of the goods. Further, the user indemnifies TI from all claims arising from the handling or use of the goods.

Should this evaluation board/kit not meet the specifications indicated in the User's Guide, the board/kit may be returned within 30 days from the date of delivery for a full refund. THE FOREGOING LIMITED WARRANTY IS THE EXCLUSIVE WARRANTY MADE BY SELLER TO BUYER AND IS IN LIEU OF ALL OTHER WARRANTIES, EXPRESSED, IMPLIED, OR STATUTORY, INCLUDING ANY WARRANTY OF MERCHANTABILITY OR FITNESS FOR ANY PARTICULAR PURPOSE. EXCEPT TO THE EXTENT OF THE INDEMNITY SET FORTH ABOVE, NEITHER PARTY SHALL BE LIABLE TO THE OTHER FOR ANY INDIRECT, SPECIAL, INCIDENTAL, OR CONSEQUENTIAL DAMAGES.

Please read the User's Guide and, specifically, the Warnings and Restrictions notice in the User's Guide prior to handling the product. This notice contains important safety information about temperatures and voltages. For additional information on TI's environmental and/or safety programs, please visit [www.ti.com/esh](http://www.ti.com/esh) or contact TI.

No license is granted under any patent right or other intellectual property right of TI covering or relating to any machine, process, or combination in which such TI products or services might be or are used. TI currently deals with a variety of customers for products, and therefore our arrangement with the user is not exclusive. TI assumes no liability for applications assistance, customer product design, software performance, or infringement of patents or services described herein.

## REGULATORY COMPLIANCE INFORMATION

As noted in the EVM User's Guide and/or EVM itself, this EVM and/or accompanying hardware may or may not be subject to the Federal Communications Commission (FCC) and Industry Canada (IC) rules.

For EVMs **not** subject to the above rules, this evaluation board/kit/module is intended for use for ENGINEERING DEVELOPMENT, DEMONSTRATION OR EVALUATION PURPOSES ONLY and is not considered by TI to be a finished end product fit for general consumer use. It generates, uses, and can radiate radio frequency energy and has not been tested for compliance with the limits of computing devices pursuant to part 15 of FCC or ICES-003 rules, which are designed to provide reasonable protection against radio frequency interference. Operation of the equipment may cause interference with radio communications, in which case the user at his own expense will be required to take whatever measures may be required to correct this interference.

### General Statement for EVMs including a radio

*User Power/Frequency Use Obligations:* This radio is intended for development/professional use only in legally allocated frequency and power limits. Any use of radio frequencies and/or power availability of this EVM and its development application(s) must comply with local laws governing radio spectrum allocation and power limits for this evaluation module. It is the user's sole responsibility to only operate this radio in legally acceptable frequency space and within legally mandated power limitations. Any exceptions to this are strictly prohibited and unauthorized by Texas Instruments unless user has obtained appropriate experimental/development licenses from local regulatory authorities, which is responsibility of user including its acceptable authorization.

### For EVMs annotated as FCC – FEDERAL COMMUNICATIONS COMMISSION Part 15 Compliant

#### Caution

This device complies with part 15 of the FCC Rules. Operation is subject to the following two conditions: (1) This device may not cause harmful interference, and (2) this device must accept any interference received, including interference that may cause undesired operation.

Changes or modifications not expressly approved by the party responsible for compliance could void the user's authority to operate the equipment.

### FCC Interference Statement for Class A EVM devices

This equipment has been tested and found to comply with the limits for a Class A digital device, pursuant to part 15 of the FCC Rules. These limits are designed to provide reasonable protection against harmful interference when the equipment is operated in a commercial environment. This equipment generates, uses, and can radiate radio frequency energy and, if not installed and used in accordance with the instruction manual, may cause harmful interference to radio communications. Operation of this equipment in a residential area is likely to cause harmful interference in which case the user will be required to correct the interference at his own expense.

### **FCC Interference Statement for Class B EVM devices**

This equipment has been tested and found to comply with the limits for a Class B digital device, pursuant to part 15 of the FCC Rules. These limits are designed to provide reasonable protection against harmful interference in a residential installation. This equipment generates, uses and can radiate radio frequency energy and, if not installed and used in accordance with the instructions, may cause harmful interference to radio communications. However, there is no guarantee that interference will not occur in a particular installation. If this equipment does cause harmful interference to radio or television reception, which can be determined by turning the equipment off and on, the user is encouraged to try to correct the interference by one or more of the following measures:

- Reorient or relocate the receiving antenna.
- Increase the separation between the equipment and receiver.
- Connect the equipment into an outlet on a circuit different from that to which the receiver is connected.
- Consult the dealer or an experienced radio/TV technician for help.

### **For EVMs annotated as IC – INDUSTRY CANADA Compliant**

This Class A or B digital apparatus complies with Canadian ICES-003.

Changes or modifications not expressly approved by the party responsible for compliance could void the user's authority to operate the equipment.

### **Concerning EVMs including radio transmitters**

This device complies with Industry Canada licence-exempt RSS standard(s). Operation is subject to the following two conditions: (1) this device may not cause interference, and (2) this device must accept any interference, including interference that may cause undesired operation of the device.

### **Concerning EVMs including detachable antennas**

Under Industry Canada regulations, this radio transmitter may only operate using an antenna of a type and maximum (or lesser) gain approved for the transmitter by Industry Canada. To reduce potential radio interference to other users, the antenna type and its gain should be so chosen that the equivalent isotropically radiated power (e.i.r.p.) is not more than that necessary for successful communication.

This radio transmitter has been approved by Industry Canada to operate with the antenna types listed in the user guide with the maximum permissible gain and required antenna impedance for each antenna type indicated. Antenna types not included in this list, having a gain greater than the maximum gain indicated for that type, are strictly prohibited for use with this device.

Cet appareil numérique de la classe A ou B est conforme à la norme NMB-003 du Canada.

Les changements ou les modifications pas expressément approuvés par la partie responsable de la conformité ont pu vider l'autorité de l'utilisateur pour actionner l'équipement.

### **Concernant les EVMs avec appareils radio**

Le présent appareil est conforme aux CNR d'Industrie Canada applicables aux appareils radio exempts de licence. L'exploitation est autorisée aux deux conditions suivantes : (1) l'appareil ne doit pas produire de brouillage, et (2) l'utilisateur de l'appareil doit accepter tout brouillage radioélectrique subi, même si le brouillage est susceptible d'en compromettre le fonctionnement.

### **Concernant les EVMs avec antennes détachables**

Conformément à la réglementation d'Industrie Canada, le présent émetteur radio peut fonctionner avec une antenne d'un type et d'un gain maximal (ou inférieur) approuvé pour l'émetteur par Industrie Canada. Dans le but de réduire les risques de brouillage radioélectrique à l'intention des autres utilisateurs, il faut choisir le type d'antenne et son gain de sorte que la puissance isotrope rayonnée équivalente (p.i.r.e.) ne dépasse pas l'intensité nécessaire à l'établissement d'une communication satisfaisante.

Le présent émetteur radio a été approuvé par Industrie Canada pour fonctionner avec les types d'antenne énumérés dans le manuel d'usage et ayant un gain admissible maximal et l'impédance requise pour chaque type d'antenne. Les types d'antenne non inclus dans cette liste, ou dont le gain est supérieur au gain maximal indiqué, sont strictement interdits pour l'exploitation de l'émetteur.

## **【Important Notice for Users of this Product in Japan】**

### **This development kit is NOT certified as Confirming to Technical Regulations of Radio Law of Japan**

If you use this product in Japan, you are required by Radio Law of Japan to follow the instructions below with respect to this product:

1. Use this product in a shielded room or any other test facility as defined in the notification #173 issued by Ministry of Internal Affairs and Communications on March 28, 2006, based on Sub-section 1.1 of Article 6 of the Ministry's Rule for Enforcement of Radio Law of Japan,
2. Use this product only after you obtained the license of Test Radio Station as provided in Radio Law of Japan with respect to this product, or
3. Use of this product only after you obtained the Technical Regulations Conformity Certification as provided in Radio Law of Japan with respect to this product. Also, please do not transfer this product, unless you give the same notice above to the transferee. Please note that if you could not follow the instructions above, you will be subject to penalties of Radio Law of Japan.

**Texas Instruments Japan Limited**  
**(address) 24-1, Nishi-Shinjuku 6 chome, Shinjuku-ku, Tokyo, Japan**

<http://www.tij.co.jp>

#### **【ご使用にあたっての注】**

本開発キットは技術基準適合証明を受けておりません。

本製品のご使用に際しては、電波法遵守のため、以下のいずれかの措置を取っていただく必要がありますのでご注意ください。

1. 電波法施行規則第6条第1項第1号に基づく平成18年3月28日総務省告示第173号で定められた電波暗室等の試験設備でご使用いただく。
2. 実験局の免許を取得後ご使用いただく。
3. 技術基準適合証明を取得後ご使用いただく。

なお、本製品は、上記の「ご使用にあたっての注意」を譲渡先、移転先に通知しない限り、譲渡、移転できないものとします。

上記を遵守頂けない場合は、電波法の罰則が適用される可能性があることをご留意ください。

日本テキサス・インスツルメンツ株式会社  
東京都新宿区西新宿6丁目24番1号  
西新宿三井ビル

<http://www.tij.co.jp>

## EVALUATION BOARD/KIT/MODULE (EVM) WARNINGS, RESTRICTIONS AND DISCLAIMERS

**For Feasibility Evaluation Only, in Laboratory/Development Environments.** Unless otherwise indicated, this EVM is not a finished electrical equipment and not intended for consumer use. It is intended solely for use for preliminary feasibility evaluation in laboratory/development environments by technically qualified electronics experts who are familiar with the dangers and application risks associated with handling electrical mechanical components, systems and subsystems. It should not be used as all or part of a finished end product.

Your Sole Responsibility and Risk. You acknowledge, represent and agree that:

1. You have unique knowledge concerning Federal, State and local regulatory requirements (including but not limited to Food and Drug Administration regulations, if applicable) which relate to your products and which relate to your use (and/or that of your employees, affiliates, contractors or designees) of the EVM for evaluation, testing and other purposes.
2. You have full and exclusive responsibility to assure the safety and compliance of your products with all such laws and other applicable regulatory requirements, and also to assure the safety of any activities to be conducted by you and/or your employees, affiliates, contractors or designees, using the EVM. Further, you are responsible to assure that any interfaces (electronic and/or mechanical) between the EVM and any human body are designed with suitable isolation and means to safely limit accessible leakage currents to minimize the risk of electrical shock hazard.
3. You will employ reasonable safeguards to ensure that your use of the EVM will not result in any property damage, injury or death, even if the EVM should fail to perform as described or expected.
4. You will take care of proper disposal and recycling of the EVM's electronic components and packing materials.

**Certain Instructions.** It is important to operate this EVM within TI's recommended specifications and environmental considerations per the user guidelines. Exceeding the specified EVM ratings (including but not limited to input and output voltage, current, power, and environmental ranges) may cause property damage, personal injury or death. If there are questions concerning these ratings please contact a TI field representative prior to connecting interface electronics including input power and intended loads. Any loads applied outside of the specified output range may result in unintended and/or inaccurate operation and/or possible permanent damage to the EVM and/or interface electronics. Please consult the EVM User's Guide prior to connecting any load to the EVM output. If there is uncertainty as to the load specification, please contact a TI field representative. During normal operation, some circuit components may have case temperatures greater than 60°C as long as the input and output are maintained at a normal ambient operating temperature. These components include but are not limited to linear regulators, switching transistors, pass transistors, and current sense resistors which can be identified using the EVM schematic located in the EVM User's Guide. When placing measurement probes near these devices during normal operation, please be aware that these devices may be very warm to the touch. As with all electronic evaluation tools, only qualified personnel knowledgeable in electronic measurement and diagnostics normally found in development environments should use these EVMs.

**Agreement to Defend, Indemnify and Hold Harmless.** You agree to defend, indemnify and hold TI, its licensors and their representatives harmless from and against any and all claims, damages, losses, expenses, costs and liabilities (collectively, "Claims") arising out of or in connection with any use of the EVM that is not in accordance with the terms of the agreement. This obligation shall apply whether Claims arise under law of tort or contract or any other legal theory, and even if the EVM fails to perform as described or expected.

**Safety-Critical or Life-Critical Applications.** If you intend to evaluate the components for possible use in safety critical applications (such as life support) where a failure of the TI product would reasonably be expected to cause severe personal injury or death, such as devices which are classified as FDA Class III or similar classification, then you must specifically notify TI of such intent and enter into a separate Assurance and Indemnity Agreement.

Mailing Address: Texas Instruments, Post Office Box 655303, Dallas, Texas 75265  
Copyright © 2012, Texas Instruments Incorporated

## IMPORTANT NOTICE

Texas Instruments Incorporated and its subsidiaries (TI) reserve the right to make corrections, enhancements, improvements and other changes to its semiconductor products and services per JESD46, latest issue, and to discontinue any product or service per JESD48, latest issue. Buyers should obtain the latest relevant information before placing orders and should verify that such information is current and complete. All semiconductor products (also referred to herein as "components") are sold subject to TI's terms and conditions of sale supplied at the time of order acknowledgment.

TI warrants performance of its components to the specifications applicable at the time of sale, in accordance with the warranty in TI's terms and conditions of sale of semiconductor products. Testing and other quality control techniques are used to the extent TI deems necessary to support this warranty. Except where mandated by applicable law, testing of all parameters of each component is not necessarily performed.

TI assumes no liability for applications assistance or the design of Buyers' products. Buyers are responsible for their products and applications using TI components. To minimize the risks associated with Buyers' products and applications, Buyers should provide adequate design and operating safeguards.

TI does not warrant or represent that any license, either express or implied, is granted under any patent right, copyright, mask work right, or other intellectual property right relating to any combination, machine, or process in which TI components or services are used. Information published by TI regarding third-party products or services does not constitute a license to use such products or services or a warranty or endorsement thereof. Use of such information may require a license from a third party under the patents or other intellectual property of the third party, or a license from TI under the patents or other intellectual property of TI.

Reproduction of significant portions of TI information in TI data books or data sheets is permissible only if reproduction is without alteration and is accompanied by all associated warranties, conditions, limitations, and notices. TI is not responsible or liable for such altered documentation. Information of third parties may be subject to additional restrictions.

Resale of TI components or services with statements different from or beyond the parameters stated by TI for that component or service voids all express and any implied warranties for the associated TI component or service and is an unfair and deceptive business practice. TI is not responsible or liable for any such statements.

Buyer acknowledges and agrees that it is solely responsible for compliance with all legal, regulatory and safety-related requirements concerning its products, and any use of TI components in its applications, notwithstanding any applications-related information or support that may be provided by TI. Buyer represents and agrees that it has all the necessary expertise to create and implement safeguards which anticipate dangerous consequences of failures, monitor failures and their consequences, lessen the likelihood of failures that might cause harm and take appropriate remedial actions. Buyer will fully indemnify TI and its representatives against any damages arising out of the use of any TI components in safety-critical applications.

In some cases, TI components may be promoted specifically to facilitate safety-related applications. With such components, TI's goal is to help enable customers to design and create their own end-product solutions that meet applicable functional safety standards and requirements. Nonetheless, such components are subject to these terms.

No TI components are authorized for use in FDA Class III (or similar life-critical medical equipment) unless authorized officers of the parties have executed a special agreement specifically governing such use.

Only those TI components which TI has specifically designated as military grade or "enhanced plastic" are designed and intended for use in military/aerospace applications or environments. Buyer acknowledges and agrees that any military or aerospace use of TI components which have **not** been so designated is solely at the Buyer's risk, and that Buyer is solely responsible for compliance with all legal and regulatory requirements in connection with such use.

TI has specifically designated certain components which meet ISO/TS16949 requirements, mainly for automotive use. Components which have not been so designated are neither designed nor intended for automotive use; and TI will not be responsible for any failure of such components to meet such requirements.

### Products

Audio	<a href="http://www.ti.com/audio">www.ti.com/audio</a>
Amplifiers	<a href="http://amplifier.ti.com">amplifier.ti.com</a>
Data Converters	<a href="http://dataconverter.ti.com">dataconverter.ti.com</a>
DLP® Products	<a href="http://www.dlp.com">www.dlp.com</a>
DSP	<a href="http://dsp.ti.com">dsp.ti.com</a>
Clocks and Timers	<a href="http://www.ti.com/clocks">www.ti.com/clocks</a>
Interface	<a href="http://interface.ti.com">interface.ti.com</a>
Logic	<a href="http://logic.ti.com">logic.ti.com</a>
Power Mgmt	<a href="http://power.ti.com">power.ti.com</a>
Microcontrollers	<a href="http://microcontroller.ti.com">microcontroller.ti.com</a>
RFID	<a href="http://www.ti-rfid.com">www.ti-rfid.com</a>
OMAP Applications Processors	<a href="http://www.ti.com/omap">www.ti.com/omap</a>
Wireless Connectivity	<a href="http://www.ti.com/wirelessconnectivity">www.ti.com/wirelessconnectivity</a>

### Applications

Automotive and Transportation	<a href="http://www.ti.com/automotive">www.ti.com/automotive</a>
Communications and Telecom	<a href="http://www.ti.com/communications">www.ti.com/communications</a>
Computers and Peripherals	<a href="http://www.ti.com/computers">www.ti.com/computers</a>
Consumer Electronics	<a href="http://www.ti.com/consumer-apps">www.ti.com/consumer-apps</a>
Energy and Lighting	<a href="http://www.ti.com/energy">www.ti.com/energy</a>
Industrial	<a href="http://www.ti.com/industrial">www.ti.com/industrial</a>
Medical	<a href="http://www.ti.com/medical">www.ti.com/medical</a>
Security	<a href="http://www.ti.com/security">www.ti.com/security</a>
Space, Avionics and Defense	<a href="http://www.ti.com/space-avionics-defense">www.ti.com/space-avionics-defense</a>
Video and Imaging	<a href="http://www.ti.com/video">www.ti.com/video</a>

### TI E2E Community

[e2e.ti.com](http://e2e.ti.com)