

DESCRIPTION: MALE - DIP SOLDER / MACHINED - ECONOMY

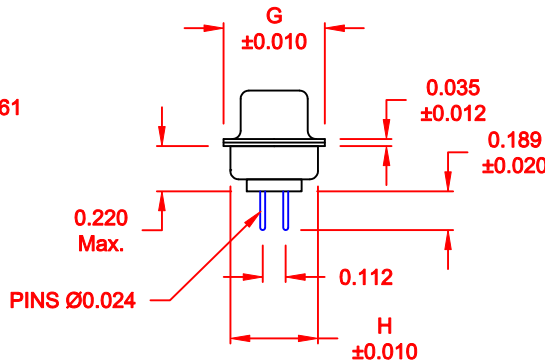
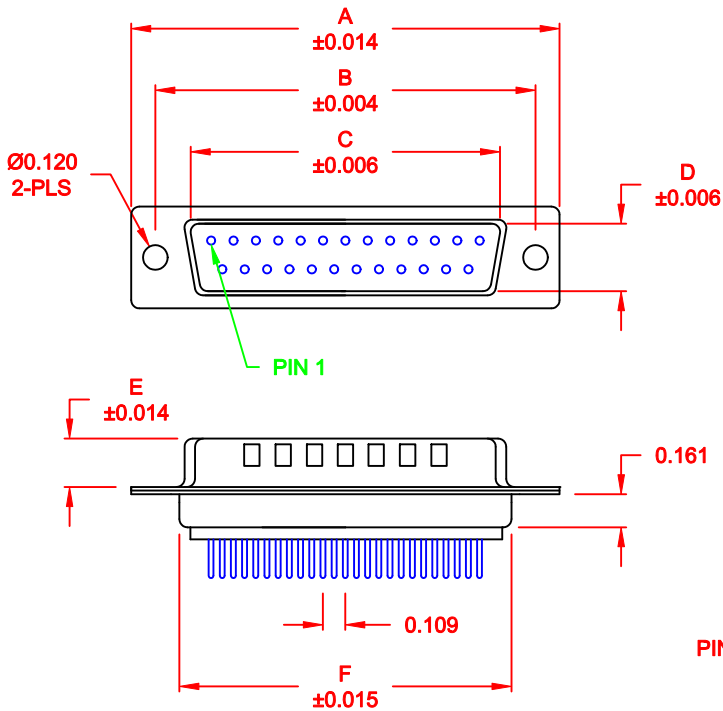

No. OF PINS	DIMENSIONS							
	A	B	C	D	E	F	G	H
9	1.213	0.984	0.666	0.329	0.236	0.756	0.496	0.427
	30.80	24.99	16.92	8.36	5.99	19.20	12.60	10.85
15	1.541	1.312	0.994	0.329	0.236	1.091	0.496	0.427
	39.15	33.32	25.25	8.36	5.99	27.70	12.60	10.85
25	2.087	1.852	1.534	0.329	0.236	1.618	0.496	0.427
	53.00	47.04	38.96	8.36	5.99	41.10	12.60	10.85
37	2.728	2.500	2.182	0.329	0.236	2.256	0.496	0.427
	69.30	63.50	55.42	8.36	5.99	57.30	12.60	10.85
50	2.638	2.406	2.079	0.436	0.240	2.169	0.602	0.527
	67.00	61.11	52.80	11.07	6.10	55.10	15.30	13.39

172-EYY-111RYY1

- SERIES: 172-EYY-111RYY1
- POSITIONS: E09, E15, E25, E37, E50
- GENDER: 1 = MALE
- TERMINATION: 1 = DIP SOLDER
- SHELL PLATING: 1 = YELLOW CHROMATE (NON-ROHS)
- HARDWARE OPTIONS: 00 = NO HARDWARE, 01 = .098" CLINCH NUT (BOARD SIDE), 02 = .236" CLINCH NUT (BOARD SIDE), 03 = .236" CLINCH NUT (MOUNTING SIDE), 05 = .237" 4-40 BOARD LOCK, 91 = .237" 4-40 SPACER/ BOARD LOCK
- PLATING OPTIONS: 1 = GOLD FLASH, 2 = 30MICRO-INCH GOLD

MATERIAL:

SHELL: STEEL, YELLOW CHROMATE
 INSULATOR: UL 94V-O RATED, WHITE PA6T
 PROCESS TEMP.: 260° PROCESS TEMPERATURE
 CONTACT: BRASS

ELECTRICAL:

CURRENT RATING: 5 AMPS
 CONTACT RESISTANCE: 15 mOhms Max.
 INSULATION RESISTANCE: 1,000 MOhms min.
 VOLTAGE: 500VAC FOR 1 MINUTE
 TEMPERATURE: -50° C TO 100° C

DO NOT SCALE FROM DRAWING

	THESE DRAWINGS AND SPECIFICATIONS ARE THE PROPERTY OF NorComp AND SHALL NOT BE REPRODUCED, COPIED OR USED AS THE BASIS FOR THE MANUFACTURE OF SALE OF APPARATUS WITHOUT WRITTEN PERMISSION.	DRAWN: PAM JENKINS CHECKED:	DATE: 11-28-05 DATE:
	<h1>NorComp</h1>	SCALE: 1:1 DWG NO. 172-EYY-111RYY1	SHEET 1 OF 3 REV 1

DESCRIPTION: PCB LAYOUT - STANDARD "D" - MALE & FEMALE

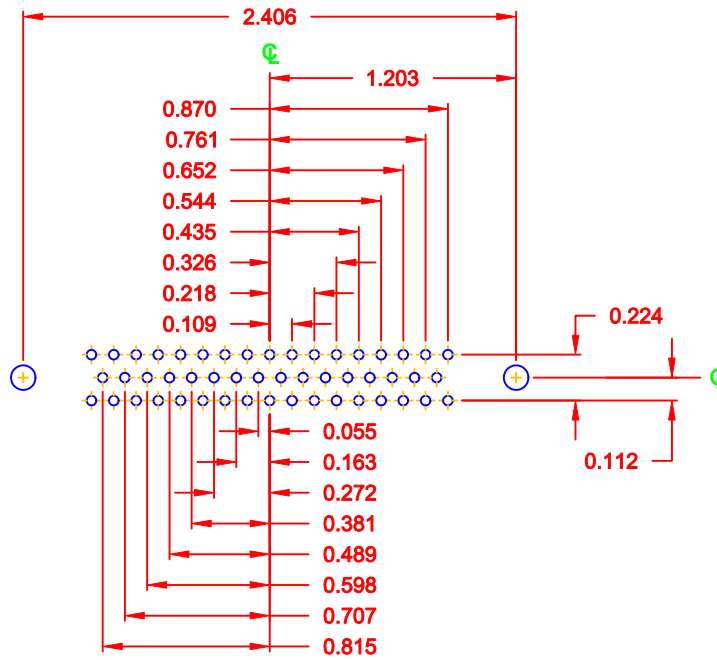
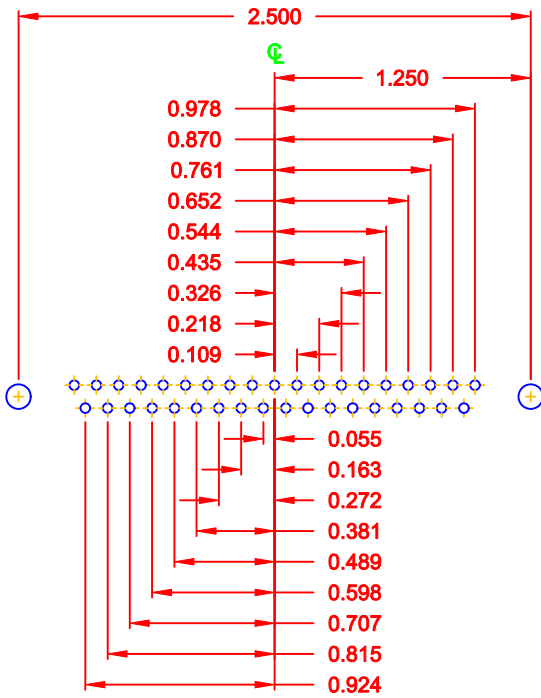
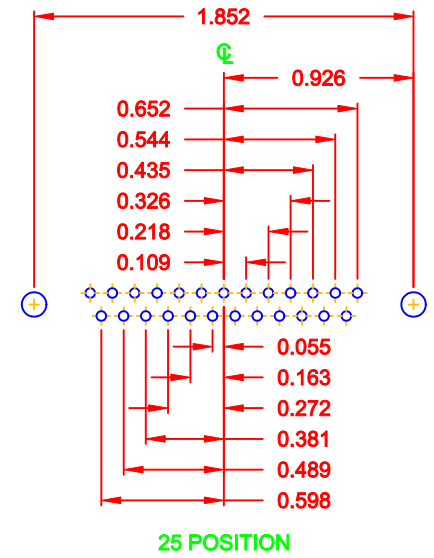
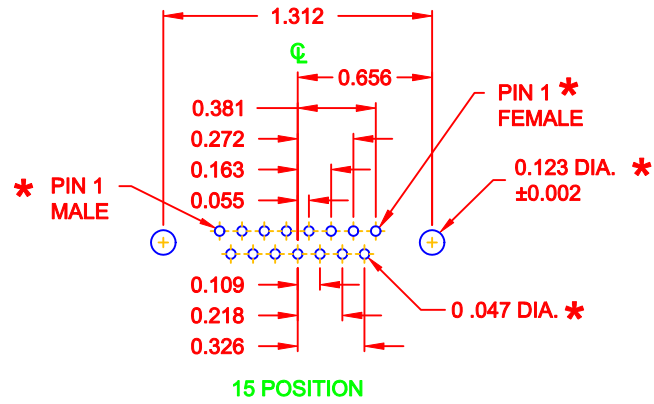
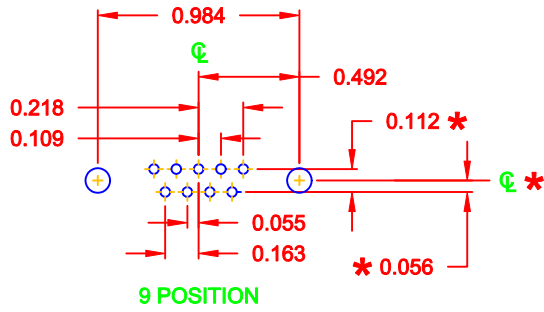

* TYP. ON ALL SIZES

DO NOT SCALE FROM DRAWING

	THESE DRAWINGS AND SPECIFICATIONS ARE THE PROPERTY OF NorComp AND SHALL NOT BE REPRODUCED, COPIED OR USED AS THE BASIS FOR THE MANUFACTURE OF SALE OF APPARATUS WITHOUT WRITTEN PERMISSION.		DRAWN: C. SMITH	DATE: 03-08-06
			CHECKED:	DATE:
<h1>NorComp</h1>	SCALE: FULL	SHEET 2 OF 3	REV 1	
	DWG NO. 172-EYY-111RYY1			

DESCRIPTION: CLINCH NUT HARDWARE

TOLERANCE:
ALL DIMENSIONS ARE ± 0.010

ALL CLINCH-NUTS ARE 4-40 INTERNAL THREADS

01X 0.098" (BOARD SIDE) - CN1

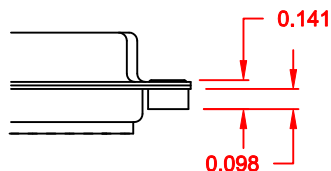

02X 0.236" (BOARD SIDE) - CN2

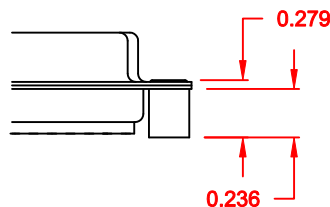

03X..... 0.236" (MATING SIDE) - CN8

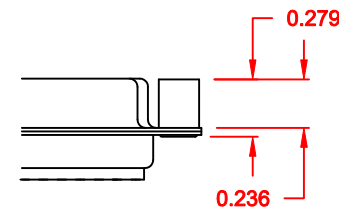

05X 0.237" (BOARD SIDE) - CN10

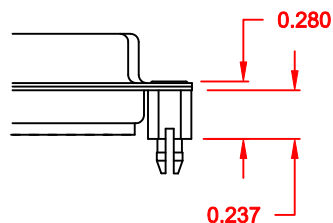

91X 0.237" BOARD SIDE
0.197" MATING SIDE
CN10/SFSO4404

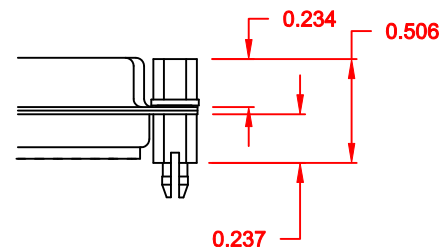

NOTE: 4-40 FEMALE SCREW LOCK IS REMOVABLE

DO NOT SCALE FROM DRAWING

	THESE DRAWINGS AND SPECIFICATIONS ARE THE PROPERTY OF NorComp AND SHALL NOT BE REPRODUCED, COPIED OR USED AS THE BASIS FOR THE MANUFACTURE OF SALE OF APPARATUS WITHOUT WRITTEN PERMISSION.		DRAWN: WAYNE ROBBINS	DATE: 11-28-05
			CHECKED:	DATE:
<h1>NorComp</h1>		SCALE:	SHEET 3 OF 3	REV 1
		DWG NO. 172-EYY-111RYY1		