



Pressure sensors

Pressure transmitter with SPI output

Series/Type: AVR 0.100 KA D4 Z14E L ST B537
Ordering code: B58621V2712B537

Date: 2020-05-26

Version: 2

Applications

- Differential pressure measurement
- Gauge pressure measurement



Features

- Piezoresistive MEMS technology
- Measured media (Port A): Air, non-aggressive gases (gas humidity 0 ... 100% r.h.). Unsuitable for substances reacting with glass, silicon, gold, epoxy glue or silicone glue.
- Measured media (Port B): Air, non-aggressive gases (gas humidity 0 ... 85% r.h., without dew) Unsuitable for substances reacting with glass, silicon, gold, aluminum, nickel, epoxy glue, silicone glue or silicone gel.
- Digital SPI output proportional to pressure: 10 ... 90% of digital output range (14 bit)
- Integrated temperature measurement
- RoHS-compatible
- Alternative pressure ranges on request
- Integrated temperature measurement on request
- Alternative configuration of SPI output on request
- I²C output on request

Dimensional drawings

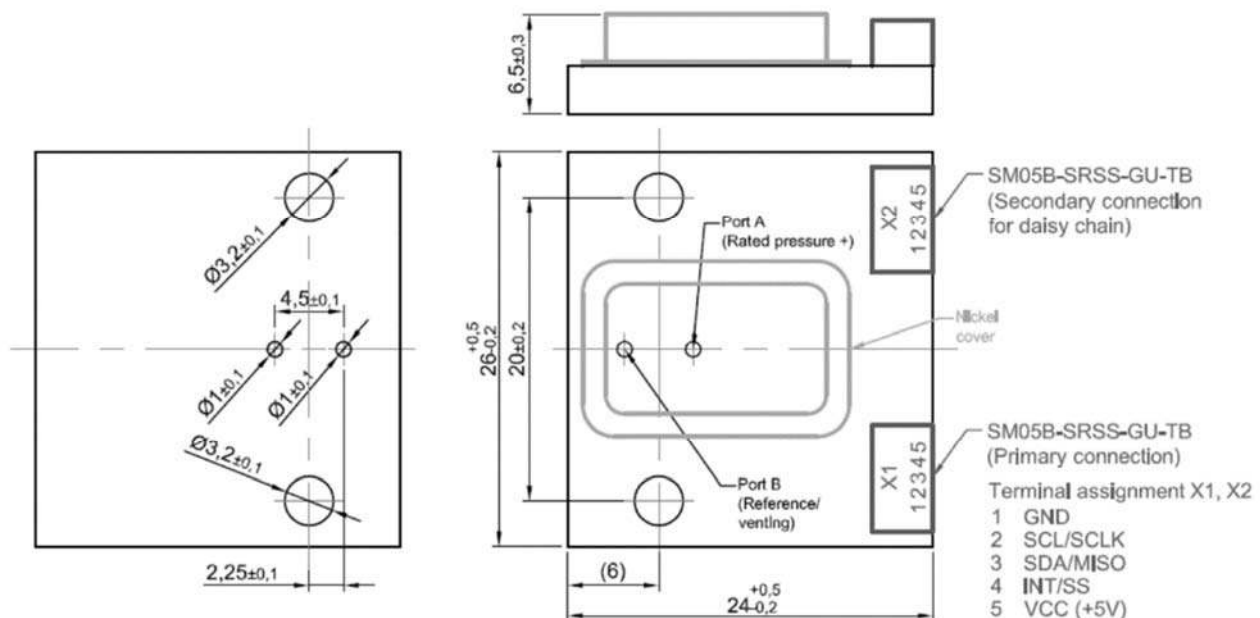

All dimensions in mm

Technical data
Absolute maximum ratings

Parameter	Symbol	Conditions	Min.	Typ.	Max.	Unit
Temperature ranges						
Storage temperature range	T_{st}	¹⁾	-30		+70	°C
Operating temperature range	T_a	²⁾	-20		+70	°C
Compensated temperature range	T_c	³⁾	-20		+70	°C
Pressure ranges						
Rated pressure range	p_r	Gauge pressure, port A ⁴⁾	-5		100	mbar
Overpressure	p_{ov}	Gauge pressure, port A ⁵⁾	-1000		1000	mbar
		Gauge pressure, port B ⁵⁾	-1000		1000	
Supply voltage /-current						
Supply voltage	V_{CC}	⁶⁾	2.7		5.5	V
Supply current	I_{CC}			3	10	mA

Parameter	Symbol	Conditions	Min.	Typ.	Max.	Unit
Output signal @ $T_a = 25\text{ °C}$, $V_{CC} = 5\text{ V}$						
Digital output range			0		16384	digit
Output @ $p_{r,min}$	$D_{pr,min}$	@ 25°C		1638		digit
Offset ^{1F)}	D_{A0}	@ 25°C ⁷⁾		2262		digit
Signal span (Full Scale)	D_{FS}	@ 25°C ⁸⁾		13107		digit
Offset error	E_{0LTS}	@ 25°C ⁹⁾		±0.2	±1	% FS
Nonlinearity	L	@ 25°C ¹⁰⁾		±0.15	±0.5	% FS
Characteristic curve error	E_c	@ $T_a = -20 \dots 70\text{ °C}$ ^{3) 11)}		±0.25	±0.75	% FS
Total error ($E_{0LTS} + E_c$)	E_{total}	@ $T_a = -20 \dots 70\text{ °C}$ ^{3) 12)}		±0.45	±1.75	% FS

Configuration, digital interface			
System clock frequency		¹³⁾	4 MHz
Update period		¹³⁾	0.5 ms
Communication type		¹³⁾	SPI
Sensor connection check		¹³⁾	inactive
Sensor short check		¹³⁾	inactive
I ² C-adress		¹³⁾	0 x 20

Anti-aliasing filter				
Attenuation reference		3Hz	0	dB
Attenuation		30Hz	8±1.5	dB
Attenuation		200Hz	32±8	dB

Characteristics

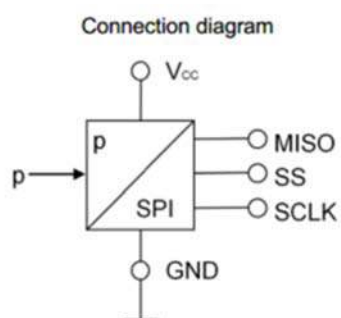
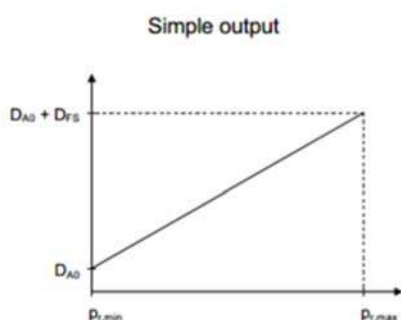

Materials in contact to the measured media

- Gloptop material based on epoxy
- Silicone adhesive
- Silicone gel
- Glass
- Silicon
- Aluminium
- Nickel
- ENIG surface on pcb

Symbols and terms

1) **Storage temperature range T_{st}**

A storage of the pressure sensor within the temperature range $T_{st,min}$ up to $T_{st,max}$ and without applied pressure and supply voltage will not affect the performance of the pressure sensor.

2) **Operating temperature range T_a**

An operation of the pressure sensor within the temperature range $T_{a,min}$ up to $T_{a,max}$ will not affect the performance of the pressure sensor.

3) **Compensated temperature range T_c**

While operating the pressure sensor within the temperature range $T_{c,min}$ up to $T_{c,max}$, the deviation of the output signal from the values at 25 °C will not exceed the temperature coefficients. Out of the compensated temperature range, the deviations may increase.

4) **Rated pressure p_r**

Within the rated pressure range $p_{r,min}$ up to $p_{r,max}$ the signal output characteristic corresponds to this specification.

5) **Over pressure p_{ov}**

Pressure cycles within the pressure range 0 up to p_{ov} will not affect the performance of the pressure sensor.

6) **Supply voltage V_{CC}**

$V_{CC,max}$ is the maximum permissible supply voltage, which can be applied without damages. $V_{CC,min}$ is the minimum required supply voltage, which has to be applied for normal operation.

7) **Offset D_{A0}**

The offset D_{A0} is the signal output D_A ($p = 0$).

8) **Signal span (Full Scale)**

$D_{FS} = FS = D_A(p_{r,max}) - D_A(p_{r,min})$

9) **Offset error E_{0LTS}**

Sum of temperature hysteresis and all non systematic offset changes.

The temperature hysteresis is the change of offset, starting from the value at 25 °C after a temperature change and return to 25 °C. Determined during temperature cycles in operating temperature range (cycles with 1 K/min).

10) **Non-linearity L (including pressure hysteresis)**

The non-linearity is the deviation of the real sensor characteristic $I_{CC} = f(p)$ from the ideal straight line.

It can be approximated by a polynomial of second order, with the maximum at $p_x = p_r / 2$.

The equation to calculate the non-linearity is:

$$L = \frac{D_A(p_x) - D_{A0} - p_x}{D_A(p_r) - D_{A0} \quad p_r}$$

11) **Characteristic curve error E_c**

Within the compensated temperature range $T_{c,min}$ up to $T_{c,max}$

the error of characteristic curve E_c is the maximum deviation to the ideal characteristic curve, including non-linearity, calibration tolerances as well as temperature errors of offset and span.

Out of the compensated temperature range, the deviations may increase.

12) **Total error $E_{total} = E_{0LTS} + E_c$**

Sum of Offset error and characteristic curve error. The offset error E_{0LTS} is a parallel translation of the whole tolerance zone of the characteristic error. A periodic (to be defined by the user) offset correction at a defined pressure (e.g. zero) may considerably improve the measurement accuracy.

13) **Functional description**

For detailed description of the SPI digital interface see the data sheet "ZSC31014_iLite_datasheet_rev1.51". (Provided by ZMDi)

IF) Significant characteristic

Internal function relevant significant characteristic

Cautions and warnings

Storage

The pressure sensors should be stored in their original packaging. They should not be placed in harmful environments such as corrosive gases nor exposed to heat or direct sunlight, which may cause deformations. Similar effects may result from extreme storage temperatures and climatic conditions.

Avoid storing the pressure sensors in an environment where condensation may form or in a location exposed to corrosive gases, which will adversely affect their performance.

Soldering

The thermal capacity of the pressure sensor is normally low, so measurements should be taken to minimize the effects of external heat. High temperatures may lead to damage or changes in characteristics.

A no-clean flux should normally be used. Flux removal processes are not recommended.

Avoid rapid cooling due to dipping in solvent. Note that the output signal may change if pressure is applied to the terminals during soldering.

Operation

Media compatibility with the pressure sensors must be ensured to prevent their failure (see page 2).

The use of inappropriate media can cause damage and malfunction.

Never use them in atmospheres containing explosive liquids or gases.

Ensure pressure equalization to the environment, if relative pressure sensors are used.

Avoid operating the pressure sensors in an environment where condensation may form or in a location exposed to corrosive gases. These environments adversely affect performance of the sensors.

If the operating pressure is not within the rated pressure range, it may change the output characteristics.

Do not exceed the rated overpressure, it may damage the pressure sensor.

Do not exceed the maximum rated supply voltage, it may damage the pressure sensor.

Do not exceed the rated storage temperature range, it may damage the pressure sensor.

Temperature variations in both the ambient conditions and the media (liquid or gas) can affect the accuracy of the output signal from the pressure sensors. Check the operating temperature range and thermal error specification of the pressure sensors to determine their suitability for the application.

Connections must be wired in accordance with the terminal assignment specified in this publication.

Care should be taken as reversed pin connections can damage the pressure sensors or degrade their performance.

Contact between the pressure sensor terminals and metals or other materials may cause errors in the output characteristics.

This listing does not claim to be complete, but merely reflects the experience of TDK Sensors AG & Co. KG.

Display of ordering codes for TDK Electronics products

The ordering code for one and the same product can be represented differently in data sheets, data books, other publications, on the company website, or in order-related documents such as shipping notes, order confirmations and product labels. **The varying representations of the ordering codes are due to different processes employed and do not affect the specifications of the respective products.** Detailed information can be found on the Internet under www.tdk-electronics.tdk.com/orderingcodes.

Important notes

The following applies to all products named in this publication:

1. Some parts of this publication contain **statements about the suitability of our products for certain areas of application**. These statements are based on our knowledge of typical requirements that are often placed on our products in the areas of application concerned. We nevertheless expressly point out **that such statements cannot be regarded as binding statements about the suitability of our products for a particular customer application**. As a rule we are either unfamiliar with individual customer applications or less familiar with them than the customers themselves. For these reasons, it is always ultimately incumbent on the customer to check and decide whether a product with the properties described in the product specification is suitable for use in a particular customer application.
2. We also point out that **in individual cases, a malfunction of electronic components or failure before the end of their usual service life cannot be completely ruled out in the current state of the art, even if they are operated as specified**. In customer applications requiring a very high level of operational safety and especially in customer applications in which the malfunction or failure of an electronic component could endanger human life or health (e.g. in accident prevention or life-saving systems), it must therefore be ensured by means of suitable design of the customer application or other action taken by the customer (e.g. installation of protective circuitry or redundancy) that no injury or damage is sustained by third parties in the event of malfunction or failure of an electronic component.
3. **The warnings, cautions and product-specific notes must be observed.**
4. In order to satisfy certain technical requirements, **some of the products described in this publication may contain substances subject to restrictions in certain jurisdictions (e.g. because they are classed as hazardous)**. Useful information on this will be found in our Material Data Sheets on the Internet (www.tdk-electronics.tdk.com/material). Should you have any more detailed questions, please contact our sales offices.
5. We constantly strive to improve our products. Consequently, **the products described in this publication may change from time to time**. The same is true of the corresponding product specifications. Please check therefore to what extent product descriptions and specifications contained in this publication are still applicable before or when you place an order.

We also **reserve the right to discontinue production and delivery of products**. Consequently, we cannot guarantee that all products named in this publication will always be available. The aforementioned does not apply in the case of individual agreements deviating from the foregoing for customer-specific products.

6. Unless otherwise agreed in individual contracts, **all orders are subject to our General Terms and Conditions of Supply**.
7. **Our manufacturing sites serving the automotive business apply the IATF 16949 standard**. The IATF certifications confirm our compliance with requirements regarding the quality management system in the automotive industry. Referring to customer requirements and customer specific requirements ("CSR") TDK always has and will continue to have the policy of respecting individual agreements. Even if IATF 16949 may appear to support the acceptance of unilateral requirements, we hereby like to emphasize that **only requirements mutually agreed upon can and will be implemented in our Quality Management System**. For clarification purposes we like to point out that obligations from IATF 16949 shall only become legally binding if individually agreed upon.

Important notes

8. The trade names EPCOS, CeraCharge, CeraDiode, CeraLink, CeraPad, CeraPlas, CSMP, CTVS, DeltaCap, DigiSiMic, ExoCore, FilterCap, FormFit, LeaXield, MiniBlue, MiniCell, MKD, MKK, ModCap, MotorCap, PCC, PhaseCap, PhaseCube, PhaseMod, PhiCap, PowerHap, PQSine, PQvar, SIFERRIT, SIFI, SIKOREL, SilverCap, SIMDAD, SiMic, SIMID, SineFormer, SIOV, ThermoFuse, WindCap, XieldCap are **trademarks registered or pending** in Europe and in other countries. Further information will be found on the Internet at www.tdk-electronics.tdk.com/trademarks.

Release 2020-05