

ScintiClear SC-14x1c-SiPM-T



ScintiClear SC-14x1c-SiPM-T

Description

ScintiClear™ SC-14x1c-SiPM-T is a new high-performance $\text{SrI}_2(\text{Eu})$ -based solid state X-ray radiation detector made in the USA. Our proprietary crystal growth, manufacturing, and encapsulation processes improve the inherently excellent properties of $\text{SrI}_2(\text{Eu})$ scintillator and utilize all the benefits of cutting edge SiPM technology. Build-in temperature sensor allows precise monitoring of SiPM/crystal temperature.

Specifications

Shape	Cuboid
Detector type	$\text{SrI}_2(\text{Eu})$
Detector size	14x14x1 mm
Energy range	From 2 keV
Typical resolution	30% at 5.9 keV
Typical sensitivity to gamma radiation, cps/ $(\mu\text{Sv}\cdot\text{h}^{-1})$	N/A
Readout	2x2 6mm SiPMs
Dimensions	17x17x18 mm
Weight	8 g
Additional Features	0.1mm Be window for low energy X-rays. Fast and standard outputs. Integrated temperature sensor

Benefits

- High sensitivity – 2cm² scintillator area
- Ultra compact design
- Fully solid state detector not sensitive to magnetic field
- Low bias requirements: 26-32V
- High signal amplitude (can be used without preamp)
- Sensor for Temperature-compensated Multichannel Analysis
- Operating temperature: -40 to 55 °C

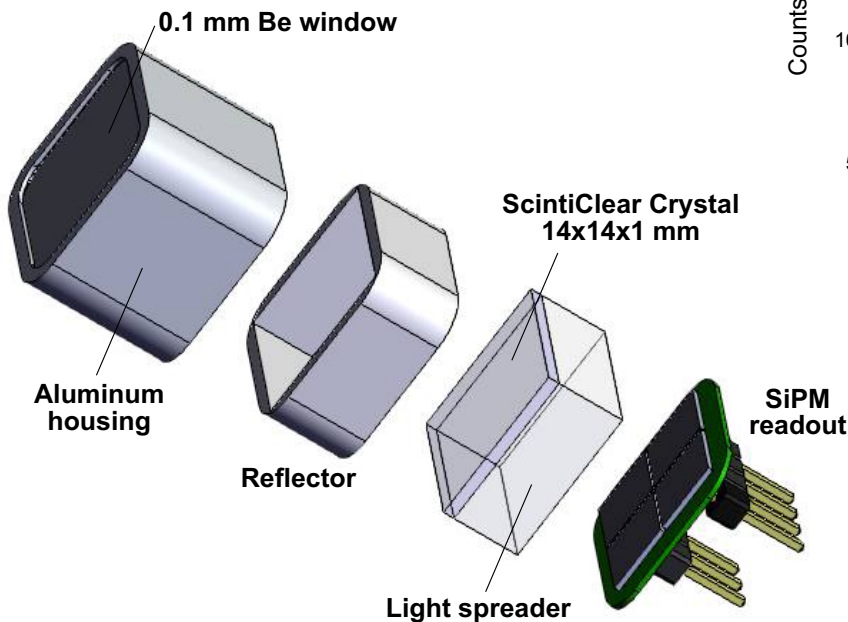
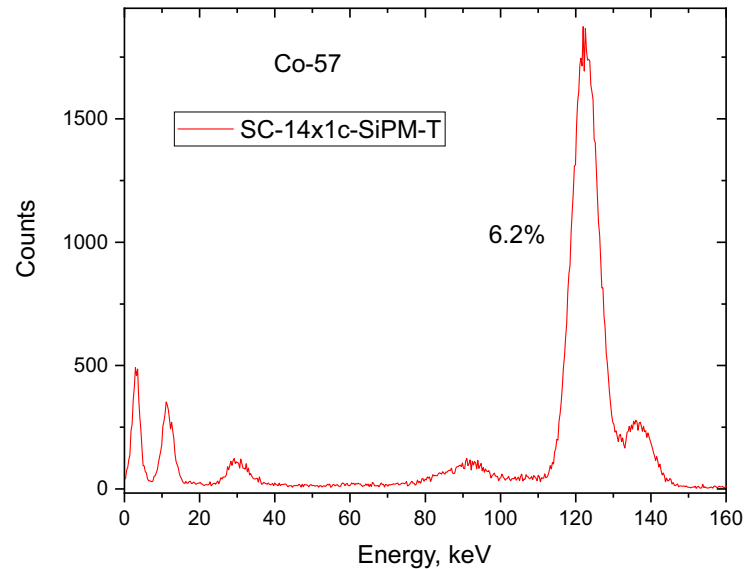

SC-14x1c-SiPM-T includes 14x14x1 mm $\text{SrI}_2(\text{Eu})$ crystal coupled to 2x2 MicroFJ SiPM array with T-sensor on the back side of the carrier board. SC-14x1c-SiPM-T has 0.1 mm thick Be window and is designed for low energy X-ray measurements down to 2 keV.

ScintiClear SC-14x1c-SiPM-T



2D drawing

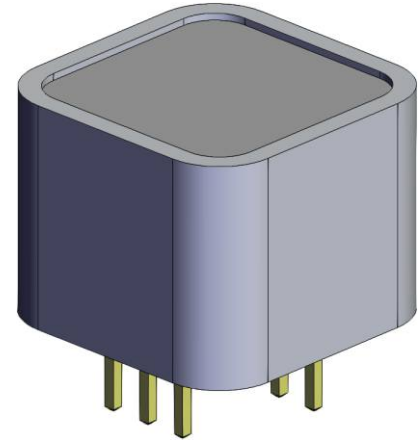
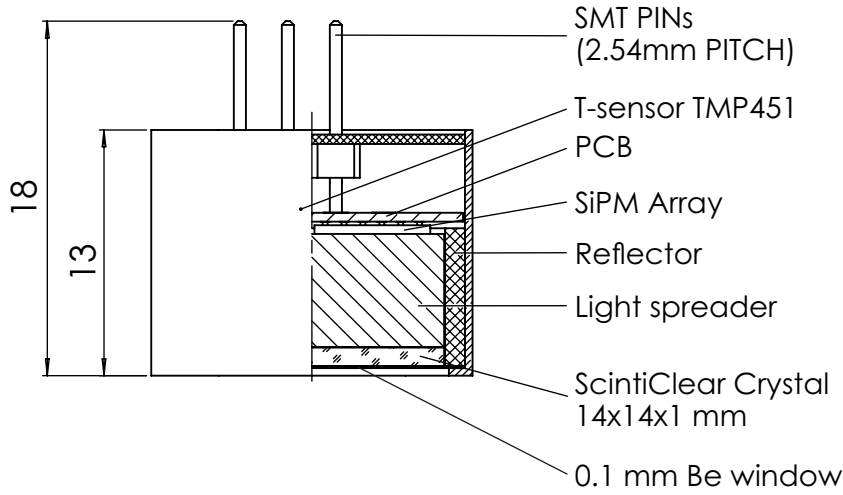

SCALE 2.5:1

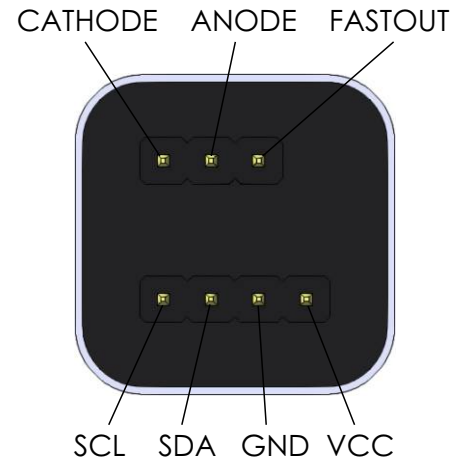
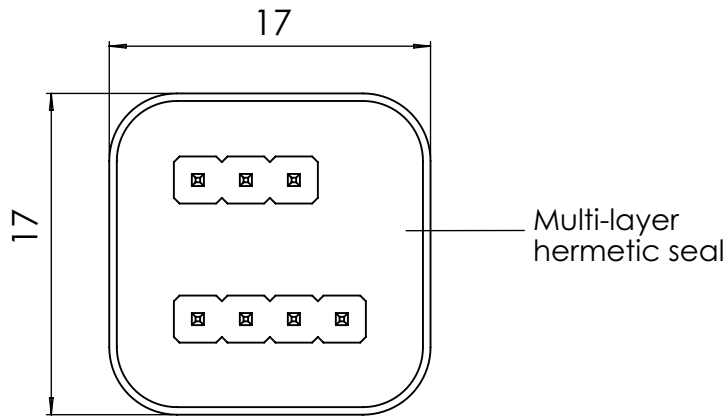

Block Diagram

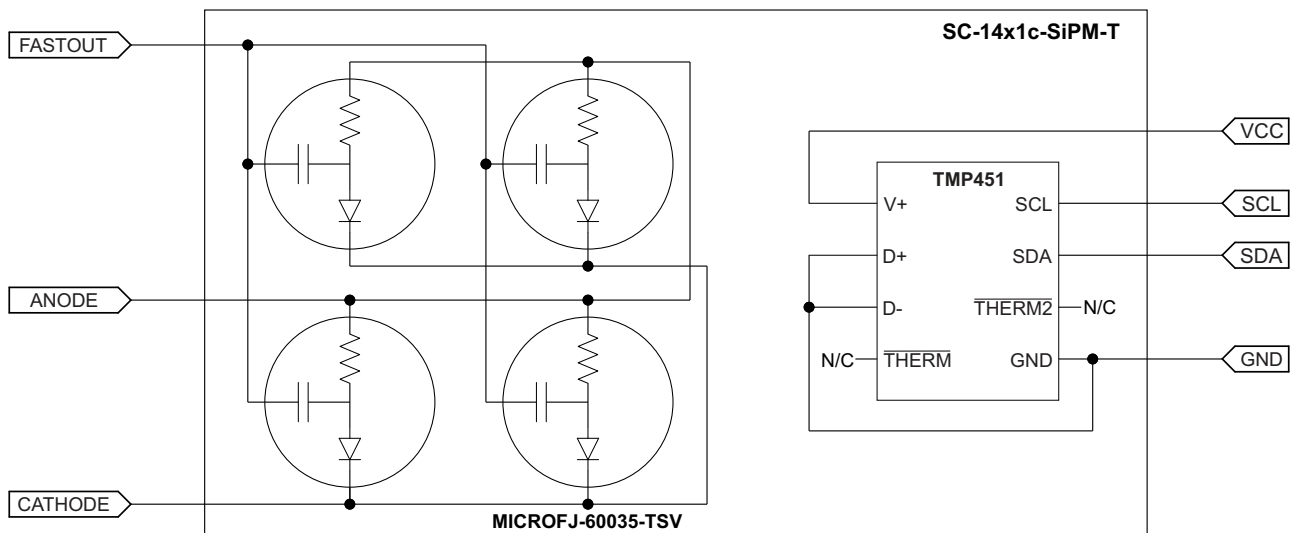



Biasing Alternatives & Signal Polarity

This Appendix lists all of the possible ways in which a J-Series SiPM can be biased. For each biasing arrangement, the standard and fast signal polarities are given. **A** and **B** are the recommended configurations. **C** and **D** will work, but are not recommended for use with the fast output. The following abbreviations are used throughout:

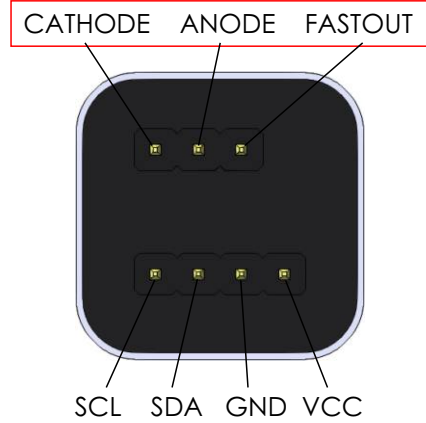

- V_{bias} = bias voltage
- S_{out} = standard output
- F_{out} = fast output
- R_s = load resistor for the standard output
- R_f = load resistor for the fast output
- V_s = standard output voltage
- V_f = fast output voltage
- R_Q = quench resistor (included on the SiPM die)
- C_1 = decoupling capacitor 10nF (50V), low ESR, ceramic

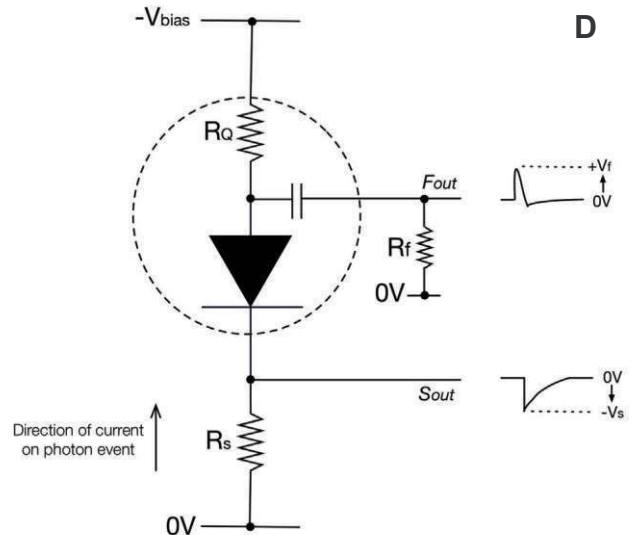
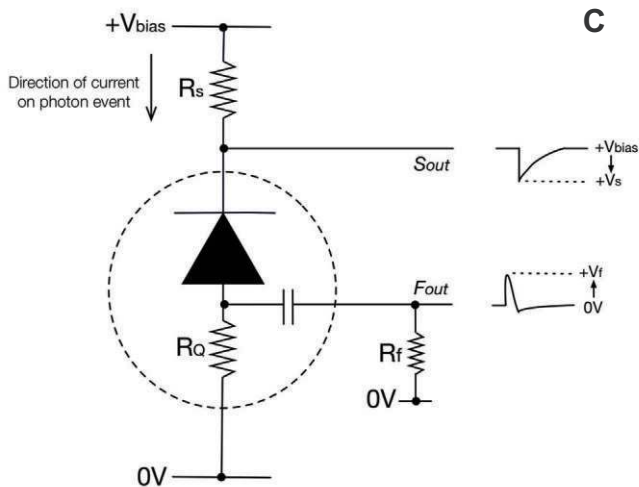
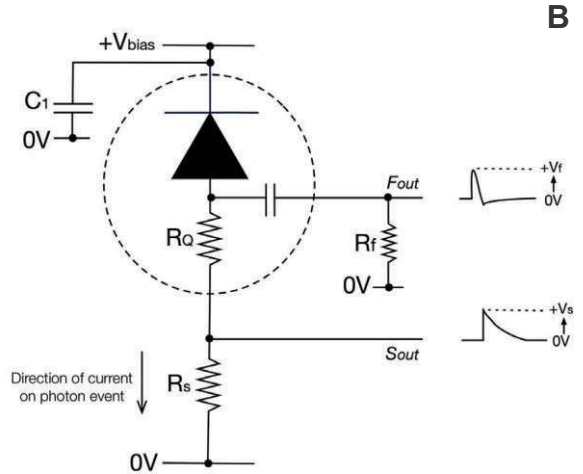
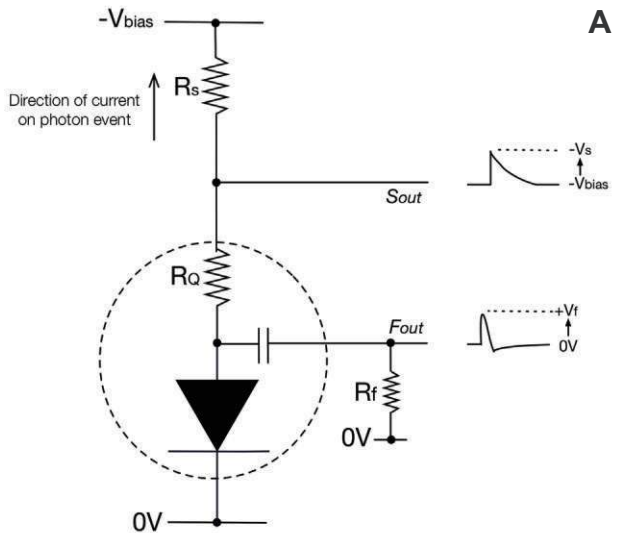

Ref.: J-Series High PDE and Timing Resolution, TSV Package, Datasheet, SensL

ScintiClear SC-14x1c-SiPM-T



TMP451 Temperature Sensor

The TMP451 device is a high-accuracy, low-power remote temperature sensor monitor with a built-in local temperature sensor.

- $\pm 1^\circ\text{C}$ Accuracy Diode
- 1.7-V to 3.6-V Supply and Logic Voltage Range
- 27- μA Operating Current
- The temperature is represented as a 12-bit digital code
- Two-Wire and SMBus™ Serial Interface
- The sensor is (SANS) specified for operation over a supply voltage range of 1.7 V to 3.6 V and a temperature range of -40°C to 125°C .

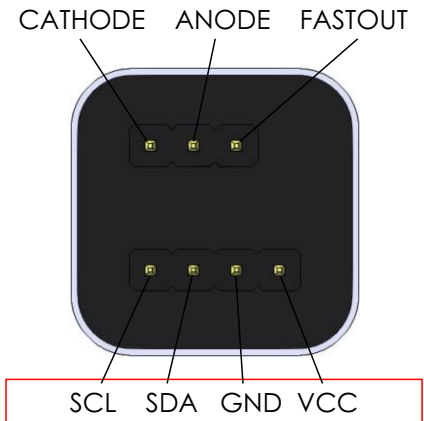

Typical Application

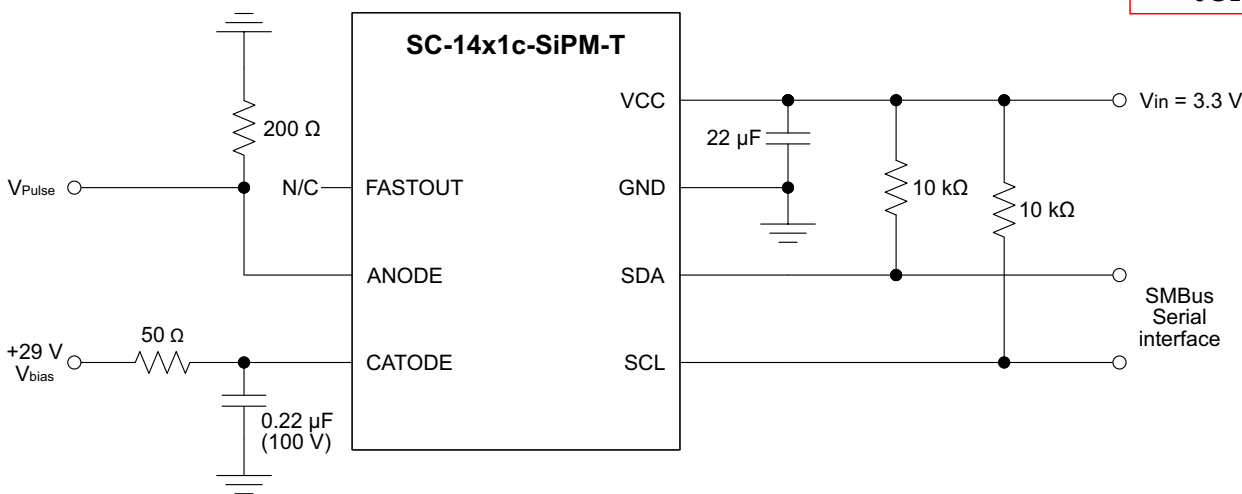

Pin Functions

PIN NAME	TYPE	DESCRIPTION
SCL	Digital input	Serial clock line for SMBus. Input; requires pullup resistor to voltage between 1.7 V and 3.6 V if driven by open-drain output.
SDA	Bidirectional digital input-output	Serial data line for SMBus. Open-drain; requires pullup resistor to voltage between 1.7 V and 3.6 V.
GND	Ground	Supply ground connection.
VCC	Power supply	Positive supply voltage, 1.7 V to 3.6 V.

Absolute Maximum Ratings

Over operating free-air temperature range, unless otherwise noted.⁽¹⁾

	MIN	MAX	UNIT
Power supply (VCC)	-0.3	3.6	V
Input voltage (SDA and SCL)	-0.3	3.6	V
Input current		10	mA
Operating temperature	-55	127	$^\circ\text{C}$
Junction temperature (T _{Jmax})		150	$^\circ\text{C}$
Storage temperature (T _{stg})	-60	150	$^\circ\text{C}$

(1) Stresses above these ratings may cause permanent damage. Exposure to absolute maximum conditions for extended periods may degrade device reliability. These are stress ratings only, and functional operation of the device at these or any other conditions beyond those specified is not implied.

Recommended Operating Conditions

Over operating free-air temperature range (unless otherwise noted)

	MIN	NOM	MAX	UNIT
Supply voltage	1.7	3.3	3.6	V
Operating free-air temperature (T _A)	-40		125	$^\circ\text{C}$

Ref.: TMP451 / SBOS686A – JUNE 2013 –
REVISED DECEMBER 2014 /
Texas Instruments



Application note: How to use “traditional” analog electronics with MacroPixel

To start acquiring spectra with MacroPixel is easy and straight-forward. All you need is the following “traditional” analog electronics available in many labs dealing with scintillators and radiation measurements:

1) Stable programmable current source, capable of providing ripple-free bias up to +30 V and limited to 0.5 mA or three 9 V batteries. Apply this bias to the cathode of the MacroPixel. Additional filter can be used to minimize the noise coming from the power supply and connection lines (Figure 1).

2) There is no need to use a preamplifier. Signal can be monitored directly from the anode of the MacroPixel connected to the ground through a 50 Ohms (up to a 1000 Ohms) resistor (Figure 2). At +30 V bias a typical pulse corresponding to 3000 keV deposited energy is about 200mV in amplitude and 20 μ s long for SC-14x25c-SiPM-T.

3) Shaping spectroscopy amplifier. The most commonly available models are: Ortec 671, 672, and 673, and Canberra 2025 or 2026.

4) Multi-channel analyzer (MCA) with a software. In our example we used Ortec’s Easy MCA with Maestro (Figure 3) but any other MCA can be used.

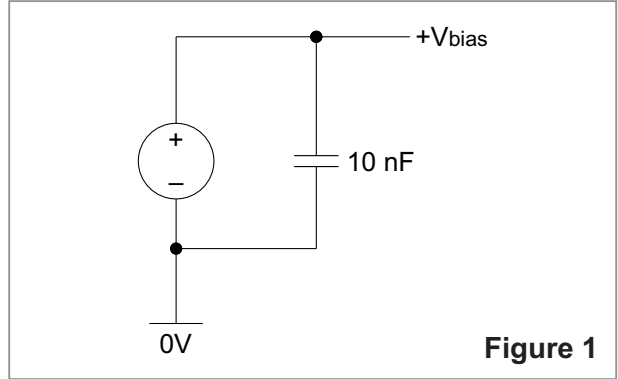

Figure 1

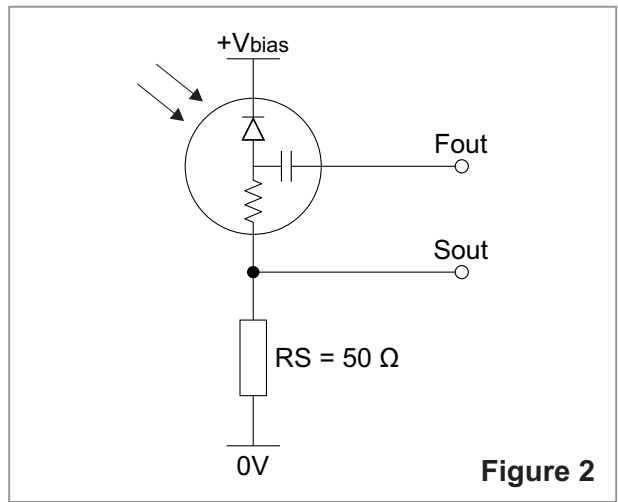

Figure 2

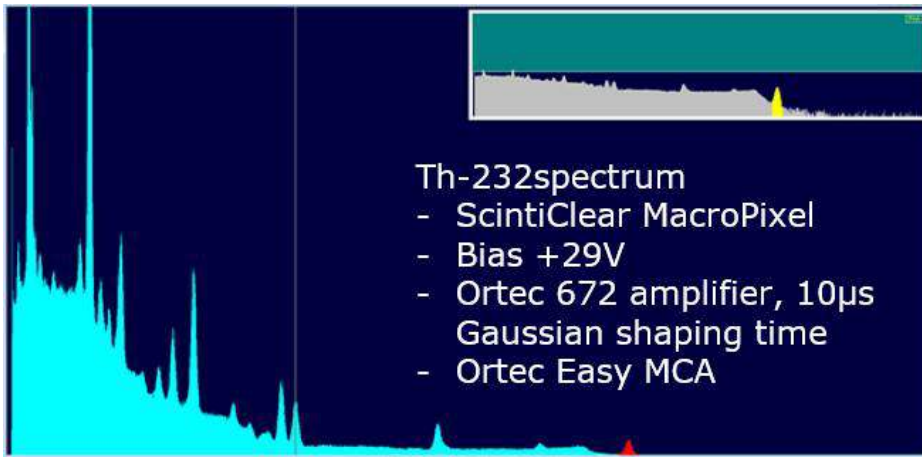

Figure 3

Th-232 emission spectrum measured with ScintiClear MacroPixel and “traditional” analog electronics. Bias +29 V, Ortec 672 amplifier, 10 μ s Gaussian shaping time, “+ NORM” input, 20 coarse gain



About CapeScint

CapeScint is a subsidiary of CapeSym, Inc. a multi-faceted company with 100+ years of combined experience in scintillators, semiconductors, and radiation detection instruments. CapeScint has its warehouse facilities and customer support staff located in Greater Boston Area, Massachusetts, USA.

Founded in 1992 as Cape Simulations, CapeSym, Inc. is now a multi-faceted company offering novel technical crystals and detectors for nuclear detection, including ScintiClear™ SrI₂(Eu) and Elpasolight™ CLYC(Ce) scintillators. In addition, CapeSym offers radiation detection instruments and equipment through www.zievert.com.

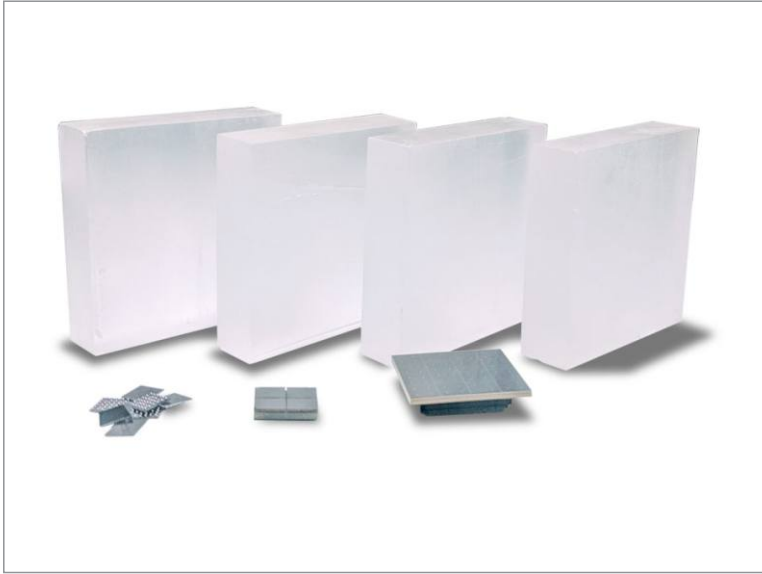

Our ongoing R&D leverages decades of experience in crystal growth, solid state physics, analytical chemistry, materials science, thermo-fluid transport, and engineering design. CapeScint as a subsidiary of CapeSym, Inc. has a long history working with the US Government as a contractor and as a supplier of essential goods and services. During the last 30 years CapeSym, Inc. and supported missions of multiple US Government agencies including NASA, MDA, USAF, DoE, DTRA, NIH, CWMD, and US Navy.



Design and specifications are subject to change without notice