

RoHS COMPLIANT 515-1204F
 Part Numbers with the "F" suffix ending are RoHS Compliant.
 Packaging is marked with "RoHS Compliant" label or equivalent markings.

REV	ECN NO	REVISIONS	DRN	CKD	APP	DATE
A		NEW RELEASE	WFB	JTD	KLJ	8-21-13

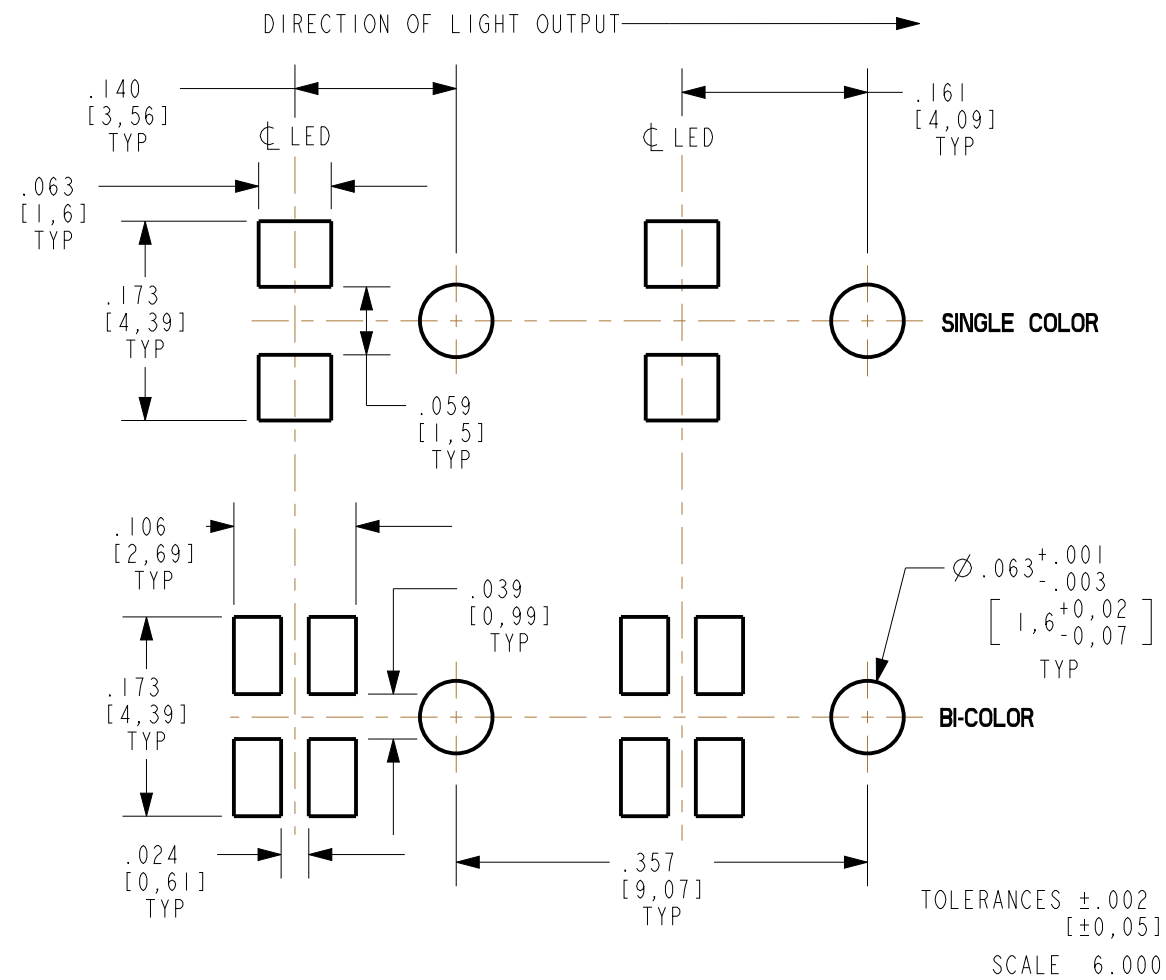
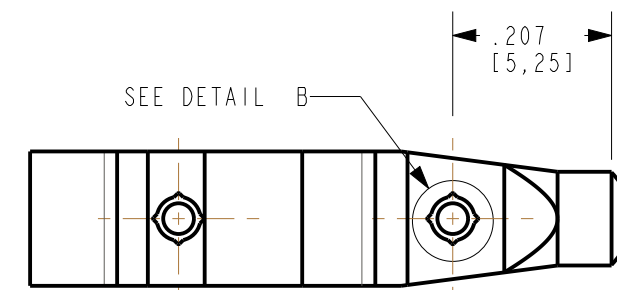
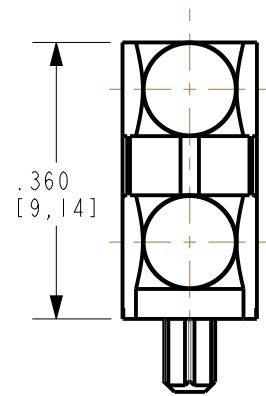
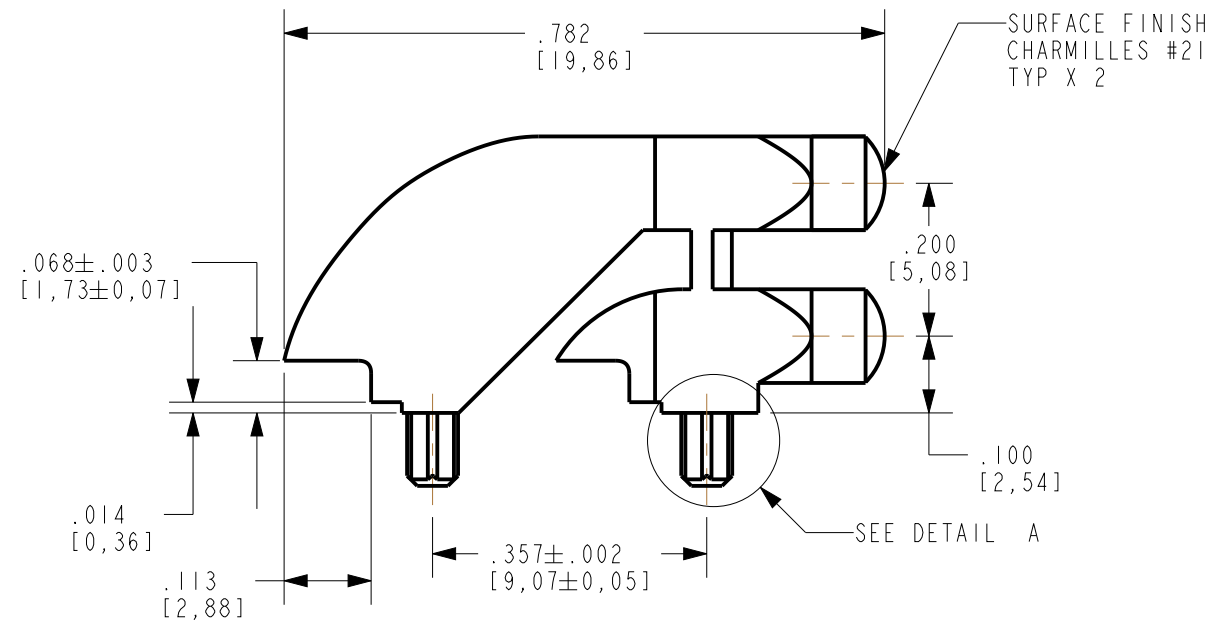
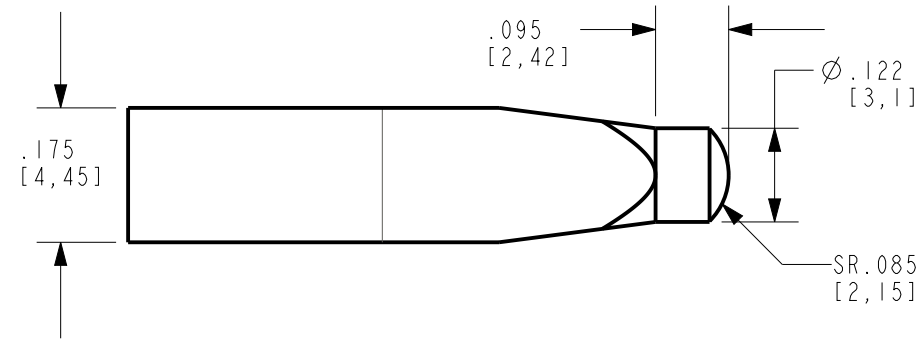
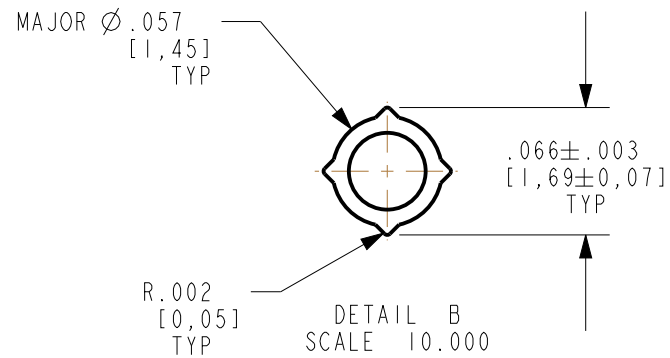
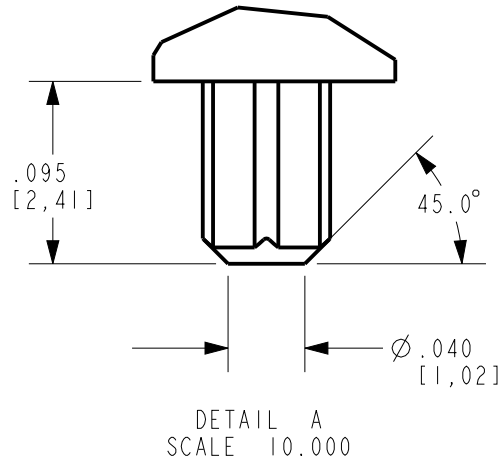

RECOMMENDED SOLDER PAD LAYOUT & HOLE PATTERN GAUGE

NOTES:

- DIALIGHT PART NUMBER 515-1204F
- UNLESS OTHERWISE SPECIFIED, ALL SURFACES MUST HAVE FINISH OF SPI A1 TO A2.
- MATERIAL TO BE CLEAR, TRANSMISSIBLE POLYCARBONATE (UL 94V-0 FLAMMABILITY).
- COMPONENTS DESIGNED TO BE PRESSED INTO PC BOARD.
- RECOMMENDED LIGHT SOURCE: DIALIGHT P/N 597-3XX2-50XF, 597-77X1-50XF OR EQUIVALENT 1208 OR 1210 PACKAGE

THIS DRAWING AND THE CONTENTS HEREIN ARE CONFIDENTIAL AND THE SOLE PROPERTY OF DIALIGHT. REPRODUCTION OF THIS DRAWING OR CONSTRUCTION OF ANY PARTS WITHIN THIS DRAWING ARE FORBIDDEN WITHOUT THE WRITTEN CONSENT OF DIALIGHT.		
SCALE: 4.000 ALL DIM'S IN: INCHES (MM)	DRAWING NUMBER C-18024	REV A
TOLERANCES: UNLESS OTHERWISE SPECIFIED FRACTIONS: ±1/64 DECIMALS (.XX): ±.01 DECIMALS (.XXX): ±.005 DECIMALS (.XXXX): ±.0005 ANGLES: ±1°	TITLE BI-LEVEL LP Ø.122 X .782 LENGTH	
FINISH: SEE NOTES	MATERIAL SEE NOTES	
FSCM 83330	Dialight 1501 ROUTE 34 SOUTH FARMINGDALE, NJ 07727	
SHEET 1 OF 1 FAMILY TABLE:		