

FF2 & FF3 SERIES

004748

Issue 4

Non-Contact Safety Switches

DESCRIPTION

The FF2 Series and FF3 Series are magnetically actuated, non-contact safety switches incorporated into a threaded plastic housing for use in machine guarding applications. These products provide a preferred solution where misalignment between guards, gates, or doors may occur and locking of the guard, gate, or door is not required. The FF2 Series has an 18 mm threaded diameter plastic housing while the FF3 Series has a 30 mm threaded diameter plastic housing. The threaded magnetic actuator of the corresponding switch diameter (18 mm or 30 mm) and hex mounting hardware are included with each switch. The FF2 and FF3 Series are certified to CE, UKCA and UL. The switches and actuators are sealed to IP67 for wet or dusty environments.

VALUE TO CUSTOMERS

- Non-contact sensing minimizes installation and set-up time
- Ø18 mm or Ø30 mm mounting for switch and actuator simplifies installation
- Cable with color-coded wire leads integral to switch reduces installation time
- Target may approach switch from head-on, slide by, or rotational/hinge for flexible installation

DIFFERENTIATION

- Non-contact sensing requires no mechanical linkage to actuate switch
- Threaded housing for switch and actuator for ease of installation
- Choice of one or two safety contacts to close when actuated
- Optional auxiliary contact closes when actuator moves out of operating range

FEATURES

- Tough, ABS threaded plastic housing with diameters of 18 mm or 30 mm
- Option of one or two safety contacts (normally closed when target is present)
- Optional auxiliary monitoring contact (normally closed when target is not sensed)
- CE, UKCA and UL508 certifications

POTENTIAL APPLICATIONS

- Equipment and machinery guards
- Can forming and filling (aluminum, steel, and plastic)
- Pick-and-place packaging equipment
- Pick-and-place assembly equipment
- Plastic molding equipment
- Printing machinery
- Semiconductor equipment
- Textile machinery
- Woodworking machinery



PORTFOLIO

Honeywell offers a wide range of FF Series magnetically actuated non-contact switches as well as other non-interlocking safety switches which include the GSS Series electromechanical limit switches, and the cable/rope pull switches (1CPS Series single head and 2CPS Series dual head). Honeywell safety interlocking switches include the metal housing EN50041 GK Series, metal housing solenoid GKL/R Series, miniature plastic housing GKM Series, EN50047 plastic housing GKE Series, and plastic housing GKN Series.

Honeywell

NON-CONTACT SAFETY SWITCHES FF2 SERIES AND FF3 SERIES

TABLE 1. SPECIFICATIONS

Characteristic	Parameter			
	FF2-10-AC (Ø18) FF2-11-AC (Ø18)	FF2-10-DC (Ø18) FF2-11-DC (Ø18)	FF3-20-AC (Ø30) FF3-21-AC (Ø30)	FF3-20-DC (Ø30) FF3-21-DC (Ø30)
Contact arrangement	1NC (FF2-10-AC) 1NC/1NO (FF2-11-AC)	1NC (FF2-10-DC) 1NC/1NO (FF2-11-DC)	2NC (FF3-20-AC) 2NC/1NO (FF3-21-AC)	2NC (FF3-20-AC) 2NC/1NO (FF3-21-AC)
Contact rating (safety contact)	2 A at 230 Vac	1 A ind./res. at 30 Vdc	2 A at 230 Vac	1 A ind./res. at 30 Vdc
Sensing distance* (safety contact)	10 mm [0.4 in] ON 30 mm [1.18 in] OFF		10 mm [0.4 in] ON 35 mm [1.38 in] OFF	
Close/drop-out/bounce (safety contact)	3 ms/2.1 ms/0.7 ms			
Contact rating (aux. contact)	15 W/10 VA			
Sensing distance* (aux. contact)	7 mm [0.28 in] OFF 14 mm [0.55 in] ON		7 mm [0.28 in] OFF 20 mm [0.79 in] ON	
Close/drop-out/bounce (aux. contact)	0.5 ms/0.3 ms/0.7 ms			
Internal fuse**	ac: 2 A fast acting	dc: 1 A fast acting	ac: 2 A fast acting	dc: 1 A fast acting
External fuse** (customer supplied)	ac: 1.6 A fast acting	dc: 0.8 A fast acting	ac: 1.6 A fast acting	dc: 0.8 A fast acting
Environmental seal rating	IP67			
Vibration/shock	50 Hz to 100 Hz/10 g			
Operating temperature	-10°C to 55°C [14°F to 131°F]			
Housing material	ABS resin filled			
Mounting and alignment	Actuator and switch concentric when safety contact actuated			
Agency certifications	CE, UKCA, UL			
Wiring	3 m [9.8 ft] pre-wired			

*Sensing distance is measured from the surface of the switch to the surface of the magnetic actuator.

**All safety contacts should be fused externally as the internal fuse is not resettable.

FIGURE 1. CONNECTION DIAGRAMS

FF2 Series

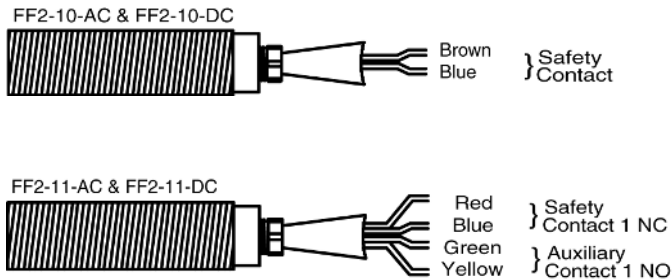

FF3 Series

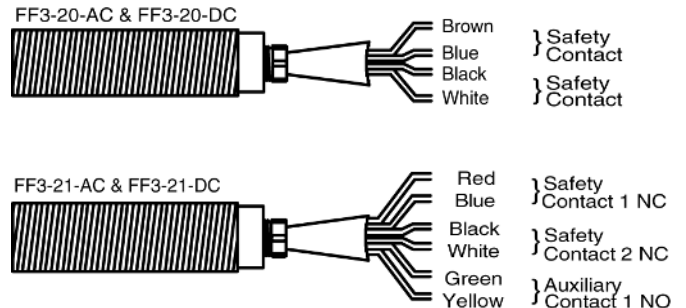

NON-CONTACT SAFETY SWITCHES FF2 SERIES AND FF3 SERIES

FIGURE 2. CONTACT CONFIGURATION DIAGRAMS*



* Contact configurations shown under closed condition for guard device. Actuator has energized switch contacts, as shown.

FIGURE 3. MOUNTING DIMENSIONS (FOR REFERENCE ONLY: mm [in])

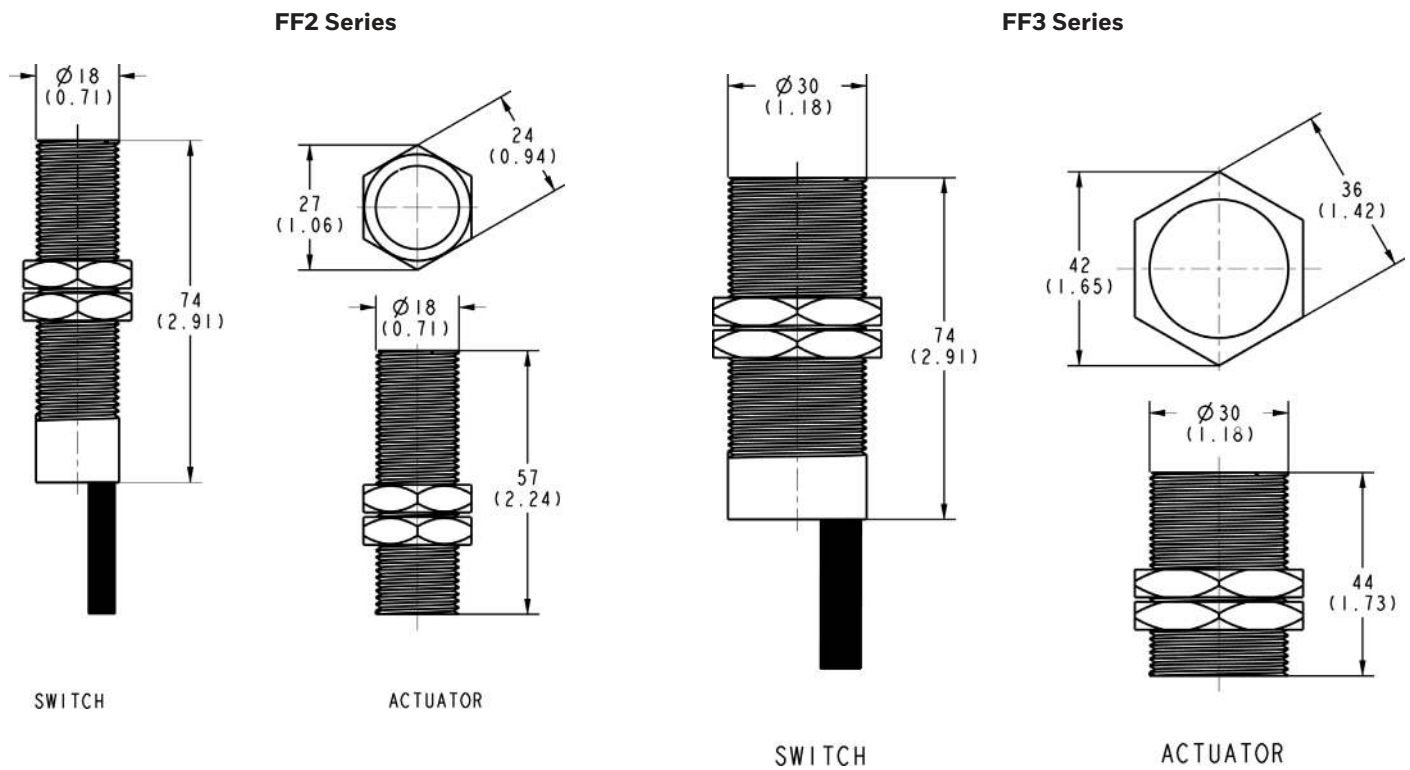

TABLE 2. ORDER GUIDE

Catalog Listing	Description
FF2 Series	
FF2-10-AC-03	FF2 Series safety switch and actuator, Ø18 mm [0.71 in], 1NC, Vac contact rating
FF2-11-AC-03	FF2 Series safety switch and actuator, Ø18 mm [0.71 in], 1NC/1NO, Vac contact rating
FF2-10-DC-03	FF2 Series safety switch and actuator, Ø18 mm [0.71 in], 1NC, Vdc contact rating
FF2-11-DC-03	FF2 Series safety switch and actuator, Ø18 mm [0.71 in], 1NC/1NO, Vdc contact rating
FF3 Series	
FF3-20-AC-03	FF3 Series safety switch and actuator, Ø30 mm [1.18 in], 2NC, Vac contact rating
FF3-21-AC-03	FF3 Series safety switch and actuator, Ø30 mm [1.18 in], 2NC/1NO, Vac contact rating
FF3-20-DC-03	FF3 Series safety switch and actuator, Ø30 mm [1.18 in], 2NC, Vdc contact rating
FF3-21-DC-03	FF3 Series safety switch and actuator, Ø30 mm [1.18 in], 2NC/1NO, Vdc contact rating

WARRANTY/REMEDY

Honeywell warrants goods of its manufacture as being free of defective materials and faulty workmanship during the applicable warranty period. Honeywell's standard product warranty applies unless agreed to otherwise by Honeywell in writing; please refer to your order acknowledgment or consult your local sales office for specific warranty details. If warranted goods are returned to Honeywell during the period of coverage, Honeywell will repair or replace, at its option, without charge those items that Honeywell, in its sole discretion, finds defective. The foregoing is buyer's sole remedy and is in lieu of all other warranties, expressed or implied, including those of merchantability and fitness for a particular purpose. In no event shall Honeywell be liable for consequential, special, or indirect damages.

While Honeywell may provide application assistance personally, through our literature and the Honeywell web site, it is buyer's sole responsibility to determine the suitability of the product in the application.

Specifications may change without notice. The information we supply is believed to be accurate and reliable as of this writing. However, Honeywell assumes no responsibility for its use.

FOR MORE INFORMATION

Honeywell Advanced Sensing Technologies services its customers through a worldwide network of sales offices and distributors. For application assistance, current specifications, pricing or the nearest Authorized Distributor, visit [our website](#) or call:

USA/Canada	+1 302 613 4491
Latin America	+1 305 805 8188
Europe	+44 1344 238258
Japan	+81 (0) 3-6730-7152
Singapore	+65 6355 2828
Greater China	+86 4006396841

Honeywell Advanced Sensing Technologies

830 East Arapaho Road
Richardson, TX 75081
sps.honeywell.com/ast

WARNING MISUSE OF DOCUMENTATION

- The information presented in this product sheet is for reference only. Do not use this document as a product installation guide.
- Complete installation, operation, and maintenance information is provided in the instructions supplied with each product.

Failure to comply with these instructions could result in death or serious injury.

WARNING IF USED IN APPLICATIONS CONCERNING HUMAN SAFETY

- Only use NC direct opening  ("positive opening"/"positive break") contacts, identified by the symbol.
- Do NOT use flexible/adjustable actuators. Only use actuators designed for safety applications.
- Do NOT defeat, tamper, remove, or bypass this switch.
- Hazardous voltage, disconnect power before servicing.
- Strictly adhere to all installation and maintenance instructions
- Consult with local safety agencies and their requirements when designing a machine-control link, interface, and all control elements that affect safety.

Failure to comply with these instructions could result in death or serious injury.