

FEATURES

- 5.8 GHz to 18 GHz frequency range
- 68 dB typical small signal gain
- 49.3 dBm typical saturated RF output power (P_{SAT})
- 61 dB gain control range with 1 dB LSB
- 20°C to +64°C operating baseplate temperature (T_{BP})
- Status and control interface 5 V TTL compatible
- 8-bit SPI attenuator control
- Overtemperature and RF OUT overvoltage standing wave ratio protection
- Alarm status communicated via control connector
- Conductively cooled through baseplate
- Active RF circuitry hermetically sealed
- Control printed wiring assemblies conformal coated for environmental protection
- Meets Grade A, high impact shock per MIL-S-901D
- Meets MIL-STD-167-1A vibration

APPLICATIONS

- Test and measurement equipment
- Electronic warfare (EW)
- Commercial and military radars

GENERAL DESCRIPTION

The HMC8114 is a 90 W, gallium nitride (GaN), monolithic microwave integrated circuit (MMIC) power amplifier (PA) module that operates between 5.8 GHz and 18 GHz, provided in an environmentally sealed chassis.

FUNCTIONAL BLOCK DIAGRAM

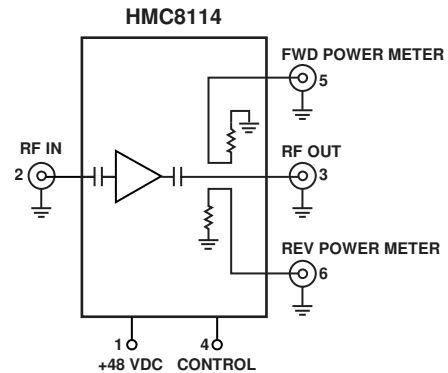

Figure 1.

The amplifier typically provides 68 dB of small signal gain and 49.3 dBm of saturated radio frequency (RF) output power. The amplifier draws 1 kW of power from a 48 V dc supply. The RF inputs and outputs are dc blocked and matched to 50 Ω for ease of use.

TABLE OF CONTENTS

Features	1	Pin Configuration and Function Descriptions.....	5
Applications.....	1	Typical Performance Characteristics	7
Functional Block Diagram	1	Theory of Operation	8
General Description	1	Applications Information	9
Revision History	2	Outline Dimensions	10
Specifications.....	3	Ordering Guide	10
Absolute Maximum Ratings.....	4		
ESD Caution.....	4		

REVISION HISTORY

10/2017—Revision 0: Initial Version

SPECIFICATIONS

Power = 48 V dc, $T_{BP} = 25^{\circ}\text{C}$, digital attenuator (DAT) set to 0 dB attenuation, unless otherwise noted.

Table 1.

Parameter	Symbol	Min	Typ	Max	Unit	Test Conditions/Comments
FREQUENCY RANGE		5.8		18	GHz	
GAIN						
Small Signal Gain		53	68		dB	Input power (P_{IN}) = -45 dBm
Power Gain			48		dB	$P_{IN} = 0$ dBm
VOLTAGE STANDING WAVE RATIO (VSWR)						
Input			2:1			
RF OUTPUT						
Saturated Output Power	P_{SAT}					$P_{IN} = 0$ dBm
5.8 GHz to 11.9 GHz			50.4		dBm	
12 GHz to 14.9 GHz			49.3		dBm	
15 GHz to 18 GHz			49.3		dBm	
Gain Control Range			61		dB	
Output Power for 1 dB Compression	OP1dB		45		dBm	
Output Third-Order Intercept	OIP3		52		dBm	
Third-Order Intermodulation Products			-37		dBc	Output power (P_{OUT}) = $P_{1dB} - 10$ dB 10 MHz spacing on two tones
Spurious			-60		dBc	Excluding harmonics
Harmonics			-16		dBc	
RF COUPLED OUTPUTS						
Forward Port Level		32	36	38	dBc	
Reverse Port Level		38	40	44	dBc	
CONTROL INPUTS						
Input Voltage						
High	V_{INH}		2.0 to 5.0		V	
Low	V_{INL}		0 to 0.8		V	
SWITCHING CHARACTERISTICS						
Cold Start			0.2		sec	$P_{IN} = -45$ dBm
Standby Mode to Enable (EN)			0.2		ms	From dc applied to the +48 VDC connector
Attenuation Level Change			0.5		ms	From rising edge of EN to the RF OUT connector
Attenuation Level Change						From rising edge of ATTN_SYNC pin to the RF OUT connector
ATTENUATION STEP ACCURACY						$P_{IN} = -45$ dBm, frequency = 12 GHz
1 dB Bit		-2	-1	0	dB	
2 dB Bit		-3	-2	-1	dB	
4 dB Bit		-5	-4	-3	dB	
8 dB Bit		-9	-8	-7	dB	
16 dB Bit		-18	-15	-14	dB	
31 dB Bit		-33	-31	-29	dB	
SUPPLY INPUTS						
Input Voltage			48		V dc	
Input Power			1050	1200	W	

ABSOLUTE MAXIMUM RATINGS

Table 2.

Parameter	Rating
RF Input (RF IN) Power	5 dBm
Operating Temperature Range	-20°C to +64°C
Storage Temperature Range	-40°C to +70°C

Stresses at or above those listed under Absolute Maximum Ratings may cause permanent damage to the product. This is a stress rating only; functional operation of the product at these or any other conditions above those indicated in the operational section of this specification is not implied. Operation beyond the maximum operating conditions for extended periods may affect product reliability.

ESD CAUTION



ESD (electrostatic discharge) sensitive device. Charged devices and circuit boards can discharge without detection. Although this product features patented or proprietary protection circuitry, damage may occur on devices subjected to high energy ESD. Therefore, proper ESD precautions should be taken to avoid performance degradation or loss of functionality.

PIN CONFIGURATION AND FUNCTION DESCRIPTIONS

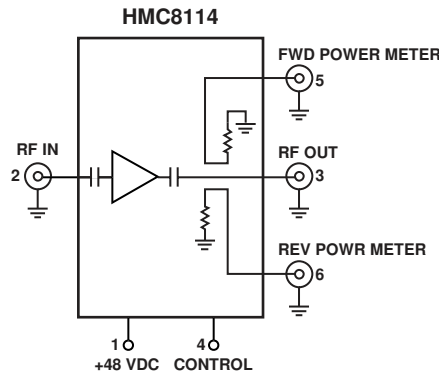

NOTES
 1. THE EXPOSED METAL PARTS OF THE CHASSIS CAN BE CONNECTED TO THE RF AND INTERNALLY GENERATED TO DC GROUND.

15285-003

Figure 2. Pin Configuration

Table 3. Connector Function Descriptions

Connector No.	Mnemonic	Description
1	+48 VDC	Supply Voltage Connector. +48 VDC connects to a 48 V dc typical source. See Table 4 for pin descriptions.
2	RF IN	RF Input. This connector is ac-coupled and matches to 50 Ω. See Table 6 for the connector type.
3	RF OUT	RF Output. This connector is ac-coupled and matched to 50 Ω. See Table 6 for the connector type.
4	CONTROL	Alarm and Command Interfaces. See Table 5 for pin descriptions. This connector contains multiple pin options available within the main connector. See Table 6 for the connector type.
5	FWD POWER METER	RF Output, Forward. This connector is ac-coupled and matched to 50 Ω. See Table 6 for the connector type.
6	REV POWER METER	RF Output, Reversed. This connector is ac-coupled and matched to 50 Ω. See Table 6 for the connector type.
Chassis	GND	Ground. The exposed metal parts of the chassis can be connected to the RF and internally generated to dc ground.

Table 4. +48 VDC Connector Pins

Pin Label	Description
A to D	48 V dc
E to H	DC return

Table 5. CONTROL Connector Pins

Pin No.	Mnemonic	High Power Amplifier (HPA) Input or Output	Description
1	VENDOR	Transistor to transistor logic (TTL) output	Low = normal
2	ALARM	TTL output	High = alarm (over/under current condition or gate voltage dropout)
	TEMPERATURE		Low = normal
3	VSWR	TTL output	High = alarm
			Low = normal
4	PWR_SUPPLY	TTL output	High = alarm
			Low = power supply not functioning properly
5, 6, 7	GROUND	Not applicable	High = normal
8	ENABLE	TTL input	Ground
			Low = standby (RF amp off)
9	RESET	TTL input	High = enabled (RF amp on)
			Low = normal
10	NC	NC	High = reset latched alarms (held high for at least 500 ns)
			Not connected
11	ATTN_CLOCK	Serial peripheral interface (SPI)	Not connected
12	ATTN_DIN	SPI	SPI clock for gain control (up to 10 MHz)
			SPI 8-bit data for gain control, clocked in on negative edge of ATTN_CLOCK ¹
13	ATTN_SYNC	SPI	SPI latch enable for gain control (active low)
14	BATTLE_MODE	TTL input	Low = normal
			High = do not shut down for alarms/self protection
15	CAPTAIN	GND/open input	Power supply alarms excluded
			Ground = allow HPA to be enabled
16, 17	GROUND	Not applicable	Open = prohibit HPA from being enabled
			Ground
18, 19	NC	NC	Ground
20, 21	NC	NC	Not connected

¹ Bit Sequence 0 0 0 0 D7 D6 D4 D3 D2 D1 D0 0 0 0 0 = 16 bits total. D7 to D0 represents the 8-bit gain control data, where D7 is the MSB.

Table 6. Connector Type

Connector No.	Mnemonic	Description or Part Number
1	+48 VDC	MS3450W22-23P
2	RF IN	N-type female jack
3	RF OUT	N-type female jack
4	CONTROL	M28840/10AC1S1
5	FWD POWER METER	N-type female jack
6	REV POWER METER	N-type female jack

TYPICAL PERFORMANCE CHARACTERISTICS

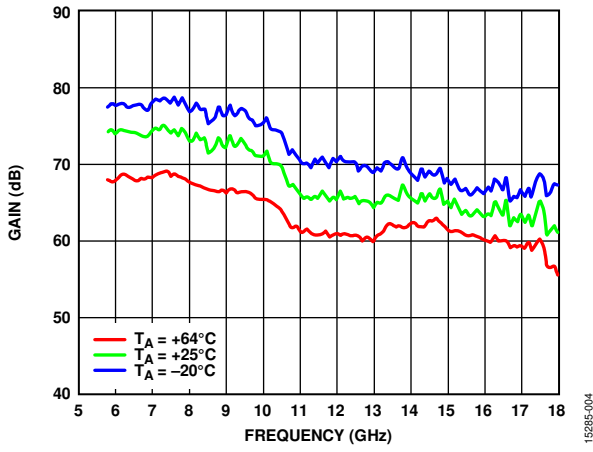

Figure 3. Gain vs. Frequency at Various Temperatures

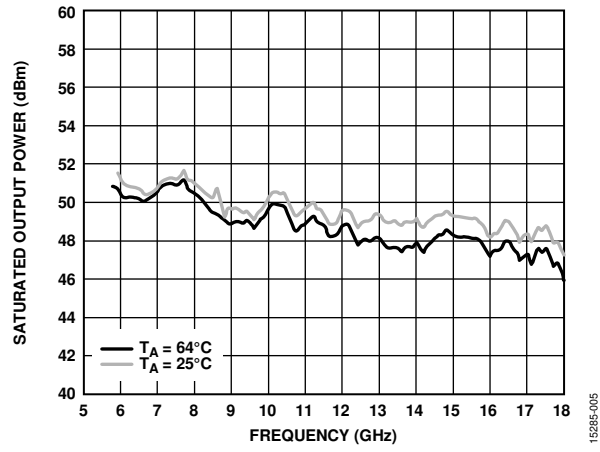

Figure 4. P_{SAT} vs. Frequency at Various Temperatures

THEORY OF OPERATION

The HMC8114 is a 90 W, GaN, MMIC PA module that operates between 5.8 GHz and 18 GHz, provided in an EIA-310D standard 5U 19-inch rack-mount chassis. The amplifier typically provides 68 dB small signal gain and 49.3 dBm saturated RF output power. The amplifier draws 1 kW of power from a 48 V dc supply.

The RF inputs and outputs are dc blocked and matched to 50 Ω for ease of use. The HMC8114 operates from a 48 V dc power supply.

The GaN MMICs in the HMC8114 are provided within a hermetically sealed module. The driver amplifiers, bias, and pulse circuitry are integrated in the HMC8114. The HMC8114 is conduction cooled, and proper cooling design is required when operating the HMC8114.

The HMC8114 meets MIL-STD-167-1A vibration and meets Grade A, high impact shock per MIL-S-901D.

APPLICATIONS INFORMATION

To turn on the amplifier, complete the following steps:

1. Apply 48 V dc to the +48 VDC pin.
2. Apply the RF input power to the RF IN pin.

To turn off the amplifier, complete the following steps:

1. Remove the RF input power from the RF IN pin.
2. Disconnect 48 V dc from the +48 VDC pin.

OUTLINE DIMENSIONS

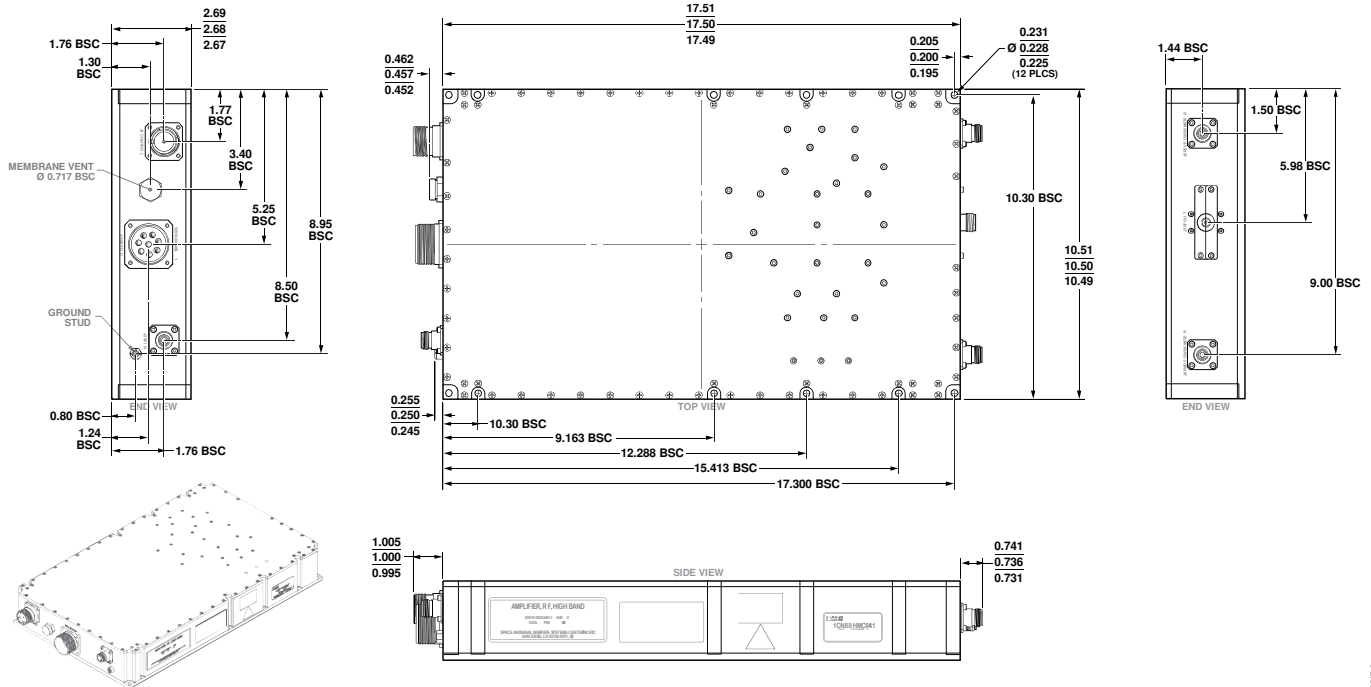

Figure 5. 6-Connectorized Module [MODULE]
(ML-6-1)
Dimensions shown in inches

ORDERING GUIDE

Model	Temperature Range	Package Description	Package Option
HMC8114	-20°C to +64°C	6-Connectorized Module [MODULE]	ML-6-1