

PART NUMBER	REVISION	DESCRIPTION	FEED TYPE
2150449-1	C	FINE CRIMP HEIGHT ADJUST	MECHANICAL
2150449-2	C	FINE CRIMP HEIGHT ADJUST	PNEUMATIC
7-2150449-1	C	MECHANICAL AND CRIMP TOOLING KIT	MECHANICAL
7-2150449-2	C	PNEUMATIC AND CRIMP TOOLING KIT	PNEUMATIC
7-2150449-7	A	CRIMP TOOLING KIT	-

ATLANTIC VERSION TERMINATOR INTERFACE ADAPTER



APPLICATOR DATA		
CRIMP	SIZE	TYPE
WIRE	3.94 mm [.155]	F
INSUL	3.94 mm [.155]	OV
APPL INSTRUCTIONS 408-35043		

TERMINAL DATA: TE TERMINAL		TE CRIMP SPECIFICATION	
TERMINAL NAME: RECEPTACLE, FASTON FLAG, AMPLIVAR			
WIRE STRIP LENGTH		INSULATION DIAMETER RANGE	
4.39-5.15 mm [.173-.203 IN]		∅2.79-3.81 mm [1.10-.150 IN]	
TERMINAL APPLICATION SPECIFICATION	114-2152		
TERMINALS APPLIED			
TE TERMINAL	TE TERMINAL	TE TERMINAL	TE TERMINAL
1742979-1			

WIRE SIZE	CRIMP HEIGHT mm [INCH]	CRIMP HEIGHT REFERENCE SETTING
8500 CMA	2.11 +/- 0.05 [.083 +/- .002]	5.3
4000 CMA	1.65 +/- 0.05 [.065 +/- .002]	10.1

- RECOMMENDED SPARE PARTS
  - REFER TO SUPPLIED INSTRUCTION SHEET FOR CLEANING, LUBRICATION AND STORAGE OF APPLICATOR.
  - APPLY PART NUMBER 2-23419-6 LOCTITE TO THREADS OF ITEM 242.
  - CRIMP HEIGHT REFERENCE SETTING WAS THE SETTING USED WHEN THE APPLICATOR WAS QUALIFIED AT THE FACTORY. ADJUSTMENT MAY BE NECESSARY WHEN RUNNING APPLICATOR IN THE FIELD.
  - TERMINAL LUBRICANT IS RECOMMENDED.
  - REFER TO TERMINAL CUSTOMER DRAWING FOR CRIMP HEIGHT FORMULA.
7. UNLESS SPECIFIED OTHERWISE TORQUE VALUES SHALL BE USED PER DOCUMENT, 101-35000.

**\*WARNING**  
ON INSTALLATION, SET WIRE DISC TO CRIMP HEIGHT REFERENCE SETTING FOR LARGEST WIRE SIZE. CRIMP HEIGHT REFERENCE SETTINGS GREATER THAN THE VALUE SHOWN MAY CAUSE DAMAGE TO THE CRIMP TOOLING. REFER TO THE INSTRUCTION SHEET FOR PROPER SETUP AND ADJUSTMENTS.

**ATLANTIC VERSION**  
Shown on sheets 1 of 4 & 2 of 4  
(Pacific version shown on sheets 3 of 4 & 4 of 4)

LOC	DIST	REVISIONS					
		P	LTN	DESCRIPTION	DATE	DWN	APVD
A	66			RELEASED	16JAN2015	KS	TE
				ECR-23-166935	20FEB2023	JWC	TE
				ECR-23-168351	06MAR2023	JWC	TE

-	1	-	1	-	2119641-1	FEED CAM, AIR FEED	248
-	1	1	1	1	2119082-4	CAM, SNAIL, INSULATION ADJUSTMENT	244
-	1	1	1	1	2079764-1	WASHER, WAVE SPRING, CREST-TO-CREST	243
	-	1	1	1	2119083-1	RETAINER, INSULATION DIAL	242
-	-	1	-	1	2119580-1	MECHANICAL FEED ASSEMBLY	239
-	1	-	1	-	2844940-3	AIR FEED MODULE	238
-	1	1	1	1	1-18028-0	WASHER, FLAT, REG M8	192
-	2	2	2	2	1-2168083-1	SCR, SKT HD CAP, RoHS, M3 X 6	191
-	REF	REF	REF	REF	994970-2	COUNTER, MAGNETIC	164
	-	1	1	1	2119955-2	ASSY, LUBRICATOR, END FEED	84
-	1	1	1	1	2-455888-4	SPACER, CRIMPER	82
-	1	1	1	1	1803607-4	DOCUMENTATION PACKAGE	71
-	2	2	2	2	3-18032-3	SCR, SET, FLT PNT, M3 X 20.0	70
-	1	1	1	1	2119740-1	TAG, IDENTIFICATION	67
-	2	2	2	2	2168078-1	SCREW, DRIVE, RH, RoHS, 2 x .188	66
-	1	1	1	1	2168083-2	SCR, SKT HD CAP, RoHS, M4 X 8.0	60
-	1	1	1	1	5-18022-5	SCR, HEX HD CAP, M4 X 6.0	59
-	-	1	-	1	2063961-1	FEED FINGER	58
-	4	4	4	4	2168400-1	SHCS, LOW HEAD, RoHS, M4 X 12	57
-	2	2	2	2	5018030-1	NUT, HEX, REG, RoHS, M3	54
-	2	2	2	2	986965-8	NUT, LOCK, HEX, TORQUE (M4)	53
-	1	-	1	-	2063961-1	FEED FINGER	51
-	1	2	1	2	18023-9	SCR, SKT HD CAP M4 X 6.0	49
-	-	1	-	1	2119652-1	FEED CAM, PRE FEED	48
-	-	1	-	1	2119653-1	FEED CAM, POST FEED	47
-	1	1	1	1	2119655-5	APPLICATOR BASIC ASSEMBLY, EF	46
-	1	1	1	1	1803517-2	RAM ASSEMBLY, EF ATLANTIC	44
-	1	1	1	1	1803602-2	SCR, BHSC, RoHS (M8 X 40)	41
-	8	8	8	8	1-18028-2	WASHER, FLAT, REG M4	33
-	2	2	2	2	2168083-8	SCR, SKT HD CAP, RoHS, M4 X 16	31
-	2	2	2	2	1-2168083-0	SCR, SKT HD CAP, RoHS, M4 X 10	29
-	1	1	1	1	240639-1	STRIPPER (MACHINING)	27
-	2	2	2	2	1-2168083-6	SCR, SKT HD CAP, RoHS, M4 X 35	25
-	1	1	1	1	2161922-5	PLATE, STRIP GUIDE	24
-	2	2	2	2	2-22281-3	SPRING, COMPRESSION	22
-	1	1	1	1	1-1633168-0	ARM, STOCK DRAG	21
-	1	1	1	1	464452-2	DRAG, STOCK	20
-	1	1	1	1	1-1901259-2	GUIDE, LOWER STRIP	19
-	1	1	1	1	4-1901695-9	STRIP GUIDE, FRONT	18
-	4	4	4	4	1-2079383-1	SCR, BHSC, RoHS (M6 X 12)	17
	-	1	1	1	461160-3	PLATE, REAR SHEAR	11
-	4	4	4	4	7-240645-4	SPACER, SHEAR PLATE	10
	-	1	1	1	455961-5	PLATE, FRONT SHEAR	9
	1	2	2	1	1-1803060-7	ANVIL, COMBINATION, END FEED	8
	-	1	1	1	2-459722-8	BLADE, SHEAR	7
-	-	-	-	-	-	-	6
-	1	1	1	1	1-238011-2	BLOCK, CRIMPER SPACER	4
	1	2	2	1	1803221-2	CRIMPER, INSULATION OVERLAP PREMIUM	3
-	1	1	1	1	2-455888-5	SPACER, CRIMPER	2
	1	2	2	1	1803188-8	CRIMPER, WIRE	1

DIMENSIONS:		TOLERANCES UNLESS OTHERWISE SPECIFIED:		MATERIAL:		FINISH:	
mm	0 PLC	±					
	1 PLC	±					
	2 PLC	±					
	3 PLC	±					
	4 PLC	±					
	ANGLES	±					
	FINISH						

CHK	L. STAKEM	30JUNE2014	DWN	L. STAKEM	30JUNE2014
CHK	G. BAILEY	30JUNE2014	APVD	T. ELRLIN	30JUNE2014
NAME		Ocean End Feed Applicator			
SIZE		CAGE CODE		DRAWING NO	
A1		00779		2150449	
Customer Accessible Production Drawing					
SCALE		SHEET		REV	
1:1		1 of 4		C	

LOC	DIST	REVISIONS					
A	66	P	LTM	DESCRIPTION	DATE	OWN	APVD
		-		SEE SHEET 1			

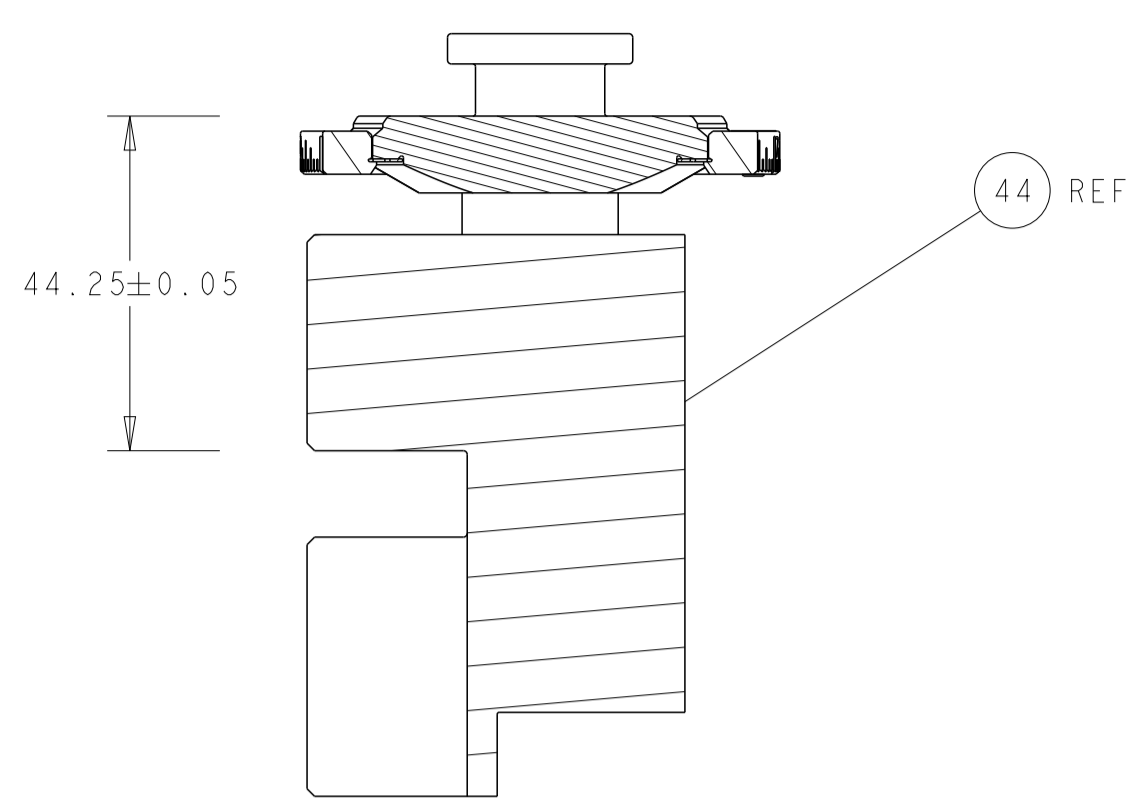

RAM SET-UP

FEED TYPE  
MECHANICAL

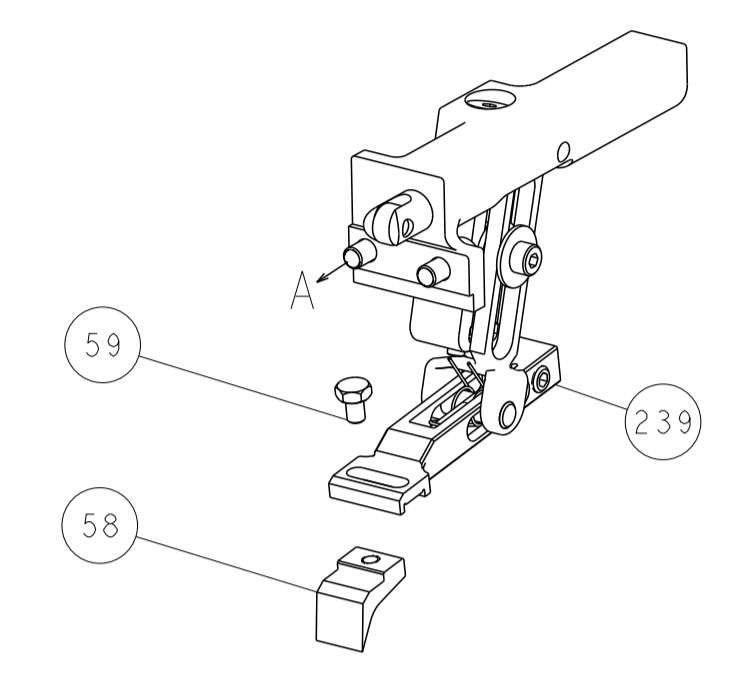

PNEUMATIC

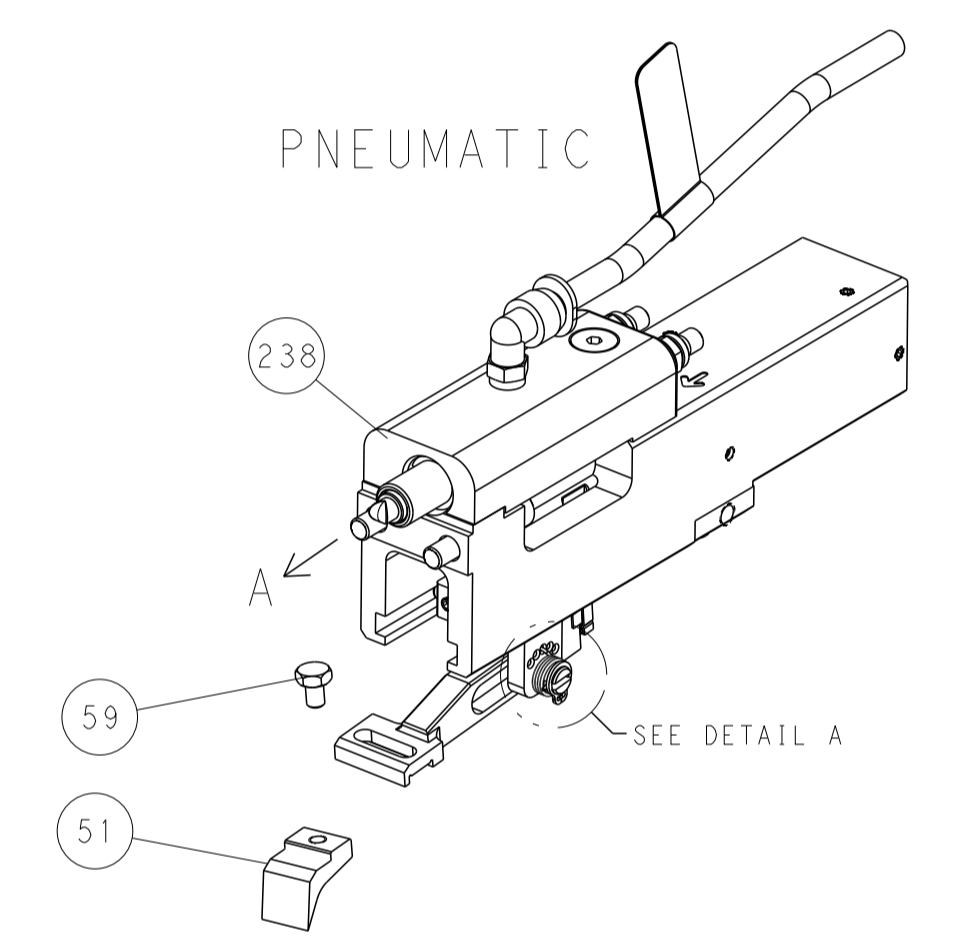

FEED SPRING  
SETTING POSITION

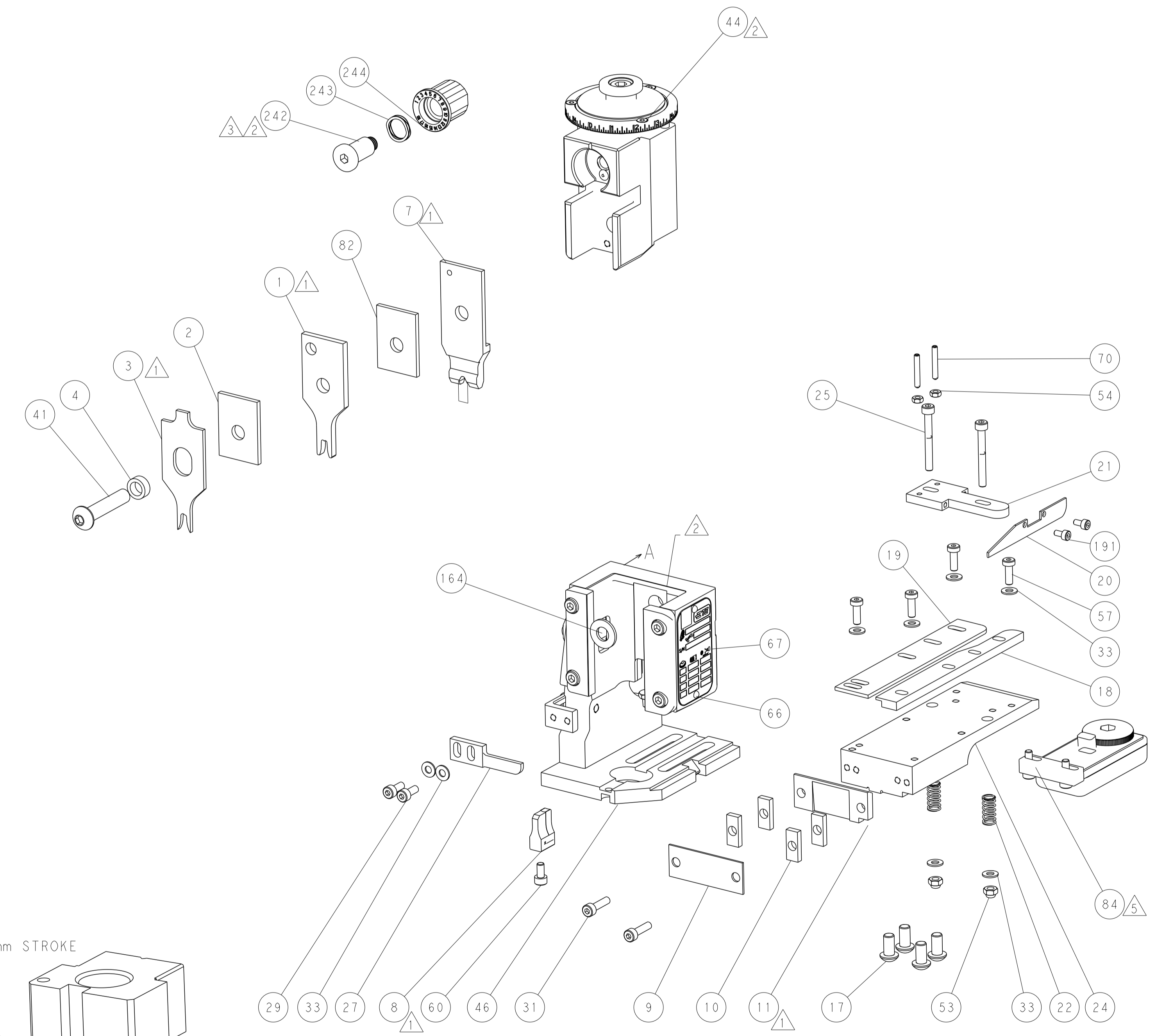
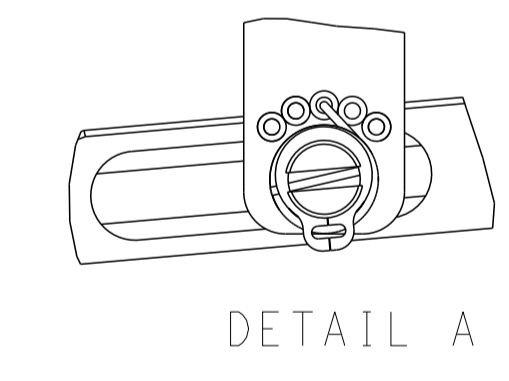

CAM POSITIONS

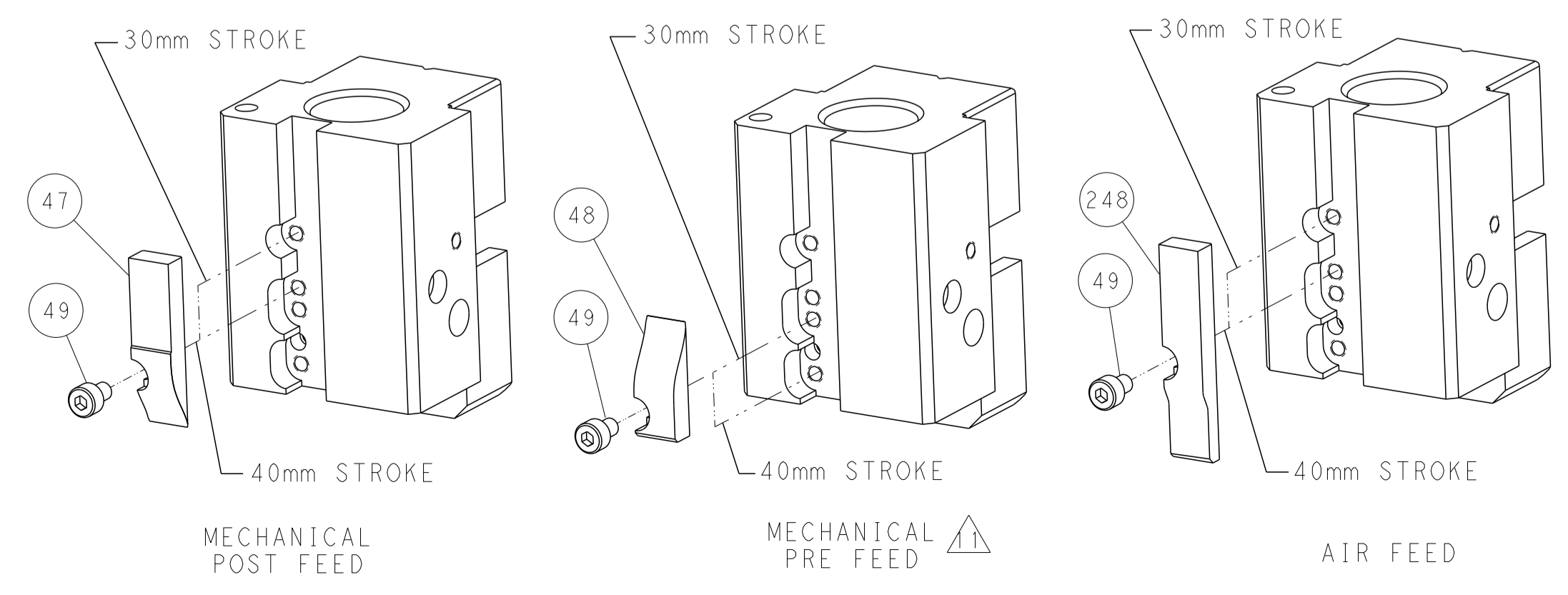

ATLANTIC VERSION  
 Shown on sheets 1 of 4 & 2 of 4  
 (Pacific version shown on sheets 3 of 4 & 4 of 4)

DIMENSIONS: mm 		TOLERANCES UNLESS OTHERWISE SPECIFIED: 0 PLC ± 1 PLC ± 2 PLC ± 3 PLC ± 4 PLC ± ANGLES ± FINISH		DWN K. STAKEM 30JUNE2014 CHK G. BAILEY 30JUNE2014 APVD T. ELRLIN 30JUNE2014 PRODUCT SPEC APPLICATION SPEC WEIGHT Customer Accessible Production Drawing		NAME Ocean End Feed Applicator SIZE CAGE CODE DRAWING NO A1 00779 C=2150449 SCALE 1:1 SHEET 2 OF 4 REV C		RESTRICTED TO TE Connectivity Harrisburg, PA 17105-3608	
-----------------------	--	---	--	---	--	--	--	---	--

PART NUMBER	REVISION	DESCRIPTION	FEED TYPE
2-2150449-1	C	FINE CRIMP HEIGHT ADJUST	MECHANICAL
2-2150449-2	C	FINE CRIMP HEIGHT ADJUST	PNEUMATIC
7-2150449-7	A	CRIMP TOOLING KIT	-

PACIFIC VERSION TERMINATOR  
INTERFACE ADAPTER

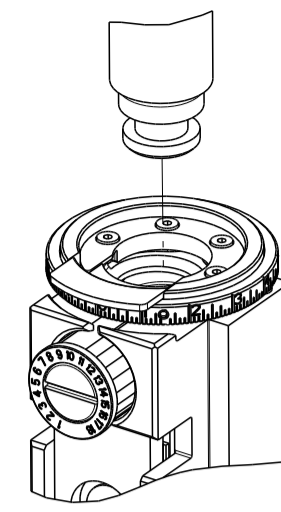

APPLICATOR DATA		
CRIMP	SIZE	TYPE
WIRE	3.94 mm [.155]	F
INSUL	3.94 mm [.155]	OV
APPL INSTRUCTIONS 408-35043		

TERMINAL DATA: TE TERMINAL		TE CRIMP SPECIFICATION	
TERMINAL NAME: RECEPTACLE, FASTON FLAG, AMPLIVAR			
WIRE STRIP LENGTH 4.39-5.15 mm [.173-.203 IN]		INSULATION DIAMETER RANGE Ø2.79-3.81 mm [.110-.150 IN]	
TERMINAL APPLICATION SPECIFICATION 114-2152			
TERMINALS APPLIED			
TE TERMINAL	TE TERMINAL	TE TERMINAL	TE TERMINAL
1742979-1			

WIRE SIZE	CRIMP HEIGHT mm [INCH]	CRIMP HEIGHT REFERENCE SETTING
8500 CMA	2.11+/-0.05 [.083+/-0.002]	5.3
4000 CMA	1.65+/-0.05 [.065+/-0.002]	10.1



- 1 RECOMMENDED SPARE PARTS
- 2 REFER TO SUPPLIED INSTRUCTION SHEET FOR CLEANING, LUBRICATION AND STORAGE OF APPLICATOR.
- 3 APPLY PART NUMBER 2-23419-6 LOCTITE TO THREADS OF ITEM 242.
- 4 CRIMP HEIGHT REFERENCE SETTING WAS THE SETTING USED WHEN THE APPLICATOR WAS QUALIFIED AT THE FACTORY. ADJUSTMENT MAY BE NECESSARY WHEN RUNNING APPLICATOR IN THE FIELD.
- 5 TERMINAL LUBRICANT IS RECOMMENDED.
- 6 REFER TO TERMINAL CUSTOMER DRAWING FOR CRIMP HEIGHT FORMULA.
- 7. UNLESS SPECIFIED OTHERWISE TORQUE VALUES SHALL BE USED PER DOCUMENT, 101-35000.

**\*WARNING**  
ON INSTALLATION, SET WIRE DISC TO CRIMP HEIGHT REFERENCE SETTING FOR LARGEST WIRE SIZE. CRIMP HEIGHT REFERENCE SETTINGS GREATER THAN THE VALUE SHOWN MAY CAUSE DAMAGE TO THE CRIMP TOOLING. REFER TO THE INSTRUCTION SHEET FOR PROPER SETUP AND ADJUSTMENTS.

**PACIFIC VERSION**  
Shown on sheets 3 of 4 & 4 of 4  
(Atlantic version shown on sheets 1 of 4 & 2 of 4)

LOC	DIST	REVISIONS					
		P	LTN	DESCRIPTION	DATE	DWN	APVD
A	66	-	-	SEE SHEET 1	-	-	-

-	1	1	2119082-4	CAM, SNAIL, INSULATION ADJUSTMENT	244	
-	1	1	2079764-1	WASHER, WAVE SPRING, CREST-TO-CREST	243	
3	-	1	2119083-1	RETAINER, INSULATION DIAL	242	
-	-	1	2119580-1	MECHANICAL FEED ASSEMBLY	239	
-	1	-	2844940-3	AIR FEED MODULE	238	
-	1	1	1-18028-0	WASHER, FLAT, REG M8	192	
-	2	2	1-2168083-1	SCR, SKT HD CAP, RoHS, M3 X 6	191	
-	4	4	2079383-9	SCR, BHSC, RoHS (M6 X 20)	186	
-	REF	REF	994970-2	COUNTER, MAGNETIC	164	
-	1	-	2119641-2	FEED CAM, AIR FEED	152	
-	1	1	2168083-8	SCR, SKT HD CAP, RoHS, M4 X 16	144	
-	-	1	2119653-2	FEED CAM, POST FEED	142	
-	1	1	2119655-6	APPLICATOR BASIC ASSEMBLY, EF	141	
-	1	1	1803518-2	RAM ASSEMBLY, EF PACIFIC	140	
5	-	1	2119955-2	ASSY, LUBRICATOR, END FEED	84	
-	1	1	2-455888-4	SPACER, CRIMPER	82	
-	1	1	1803607-4	DOCUMENTATION PACKAGE	71	
-	2	2	3-18032-3	SCR, SET, FLT PNT, M3 X 20.0	70	
-	1	1	2119740-1	TAG, IDENTIFICATION	67	
-	2	2	2168078-1	SCREW, DRIVE, RH, RoHS, 2 x .188	66	
-	1	1	5-18022-5	SCR, HEX HD CAP, M4 X 6.0	59	
-	-	1	2063961-1	FEED FINGER	58	
-	4	4	2168400-1	SHCS, LOW HEAD, RoHS, M4 X 12	57	
-	2	2	5018030-1	NUT, HEX, REG, RoHS, M3	54	
-	2	2	986965-8	NUT, LOCK, HEX, TORQUE (M4)	53	
-	1	-	2063961-1	FEED FINGER	51	
-	1	2	18023-9	SCR, SKT HD CAP M4 X 6.0	49	
-	-	1	2119652-1	FEED CAM, PRE FEED	48	
-	1	1	1803602-2	SCR, BHSC, RoHS (M8 X 40)	41	
-	8	8	1-18028-2	WASHER, FLAT, REG M4	33	
-	2	2	2168083-8	SCR, SKT HD CAP, RoHS, M4 X 16	31	
-	2	2	1-2168083-0	SCR, SKT HD CAP, RoHS, M4 X 10	29	
-	1	1	240639-1	STRIPPER (MACHINING)	27	
-	2	2	1-2168083-6	SCR, SKT HD CAP, RoHS, M4 X 35	25	
-	1	1	2161922-5	PLATE, STRIP GUIDE	24	
-	2	2	2-22281-3	SPRING, COMPRESSION	22	
-	1	1	1-1633168-0	ARM, STOCK DRAG	21	
-	1	1	464452-2	DRAG, STOCK	20	
-	1	1	1-1901259-2	GUIDE, LOWER STRIP	19	
-	1	1	4-1901695-9	STRIP GUIDE, FRONT	18	
1	-	1	461160-3	PLATE, REAR SHEAR	11	
1	-	4	7-240645-4	SPACER, SHEAR PLATE	10	
1	-	1	455961-5	PLATE, FRONT SHEAR	9	
1	-	1	1-1803060-7	ANVIL, COMBINATION, END FEED	8	
1	-	1	2-459722-8	BLADE, SHEAR	7	
-	-	-	-	-	6	
-	1	1	1-238011-2	BLOCK, CRIMPER SPACER	4	
1	-	1	1803221-2	CRIMPER, INSULATION OVERLAP PREMIUM	3	
-	1	1	2-455888-5	SPACER, CRIMPER	2	
1	-	1	1803188-8	CRIMPER, WIRE	1	
-	77	22	21	PART NO	DESCRIPTION	ITEM NO

DIMENSIONS:		TOLERANCES UNLESS OTHERWISE SPECIFIED:		DWG		NAME	
mm	0 PLC ±	1 PLC ±	2 PLC ±	3 PLC ±	4 PLC ±	5 PLC ±	6 PLC ±
	ANGLES	FINISH					
MATERIAL				WEIGHT		SCALE	

**STE** TE Connectivity  
Harrisburg, PA 17105-3608

**Ocean End Feed Applicator**

SIZE: A1 CAGE CODE: 00779 DRAWING NO: 2150449

Customer Accessible Production Drawing

LOC	DIST	REVISIONS					
A	66	P	LTN	DESCRIPTION	DATE	DWN	APVD
		-		SEE SHEET 1			

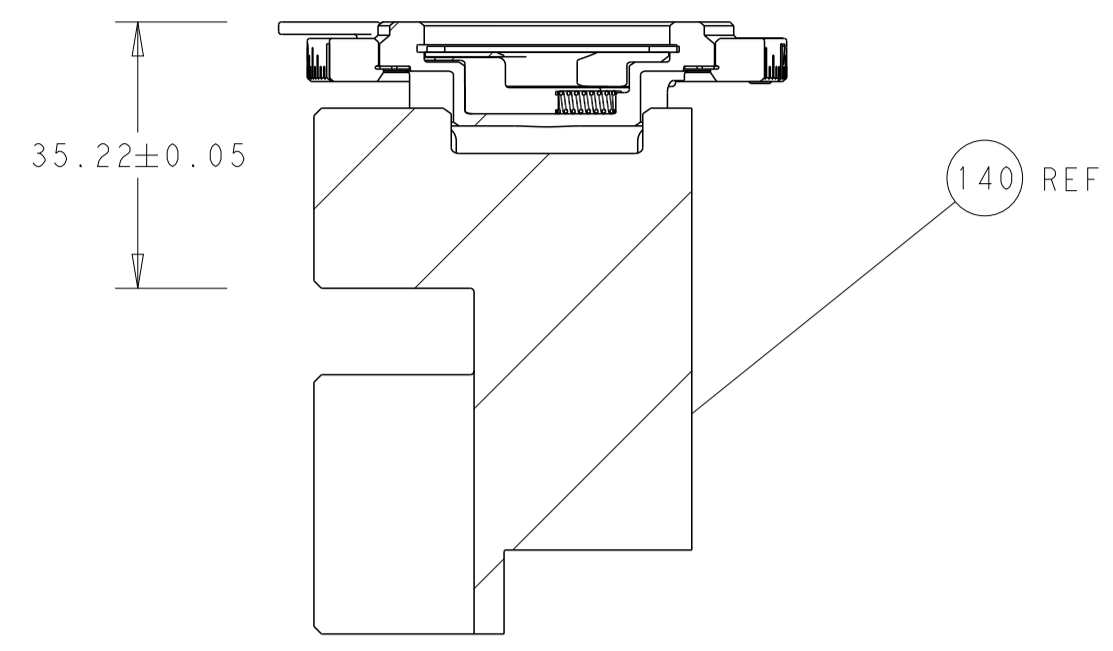

RAM SET-UP

FEED TYPE  
 MECHANICAL

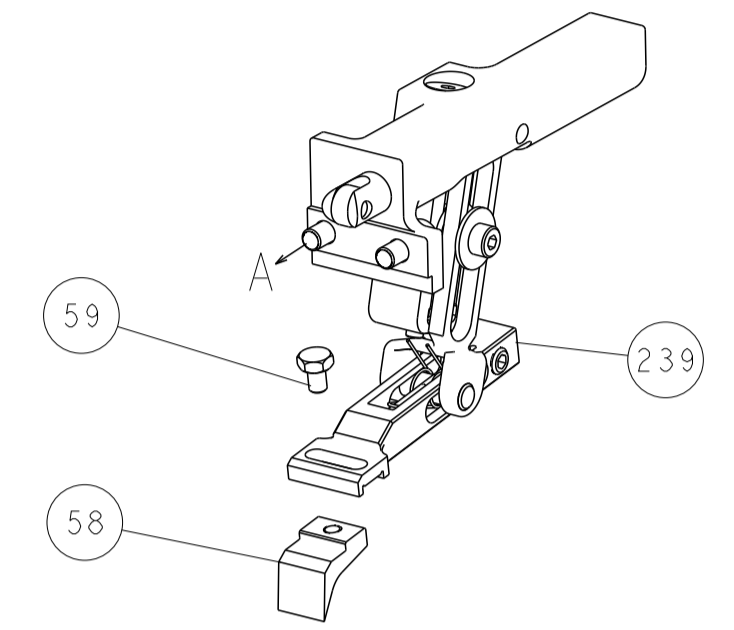

PNEUMATIC

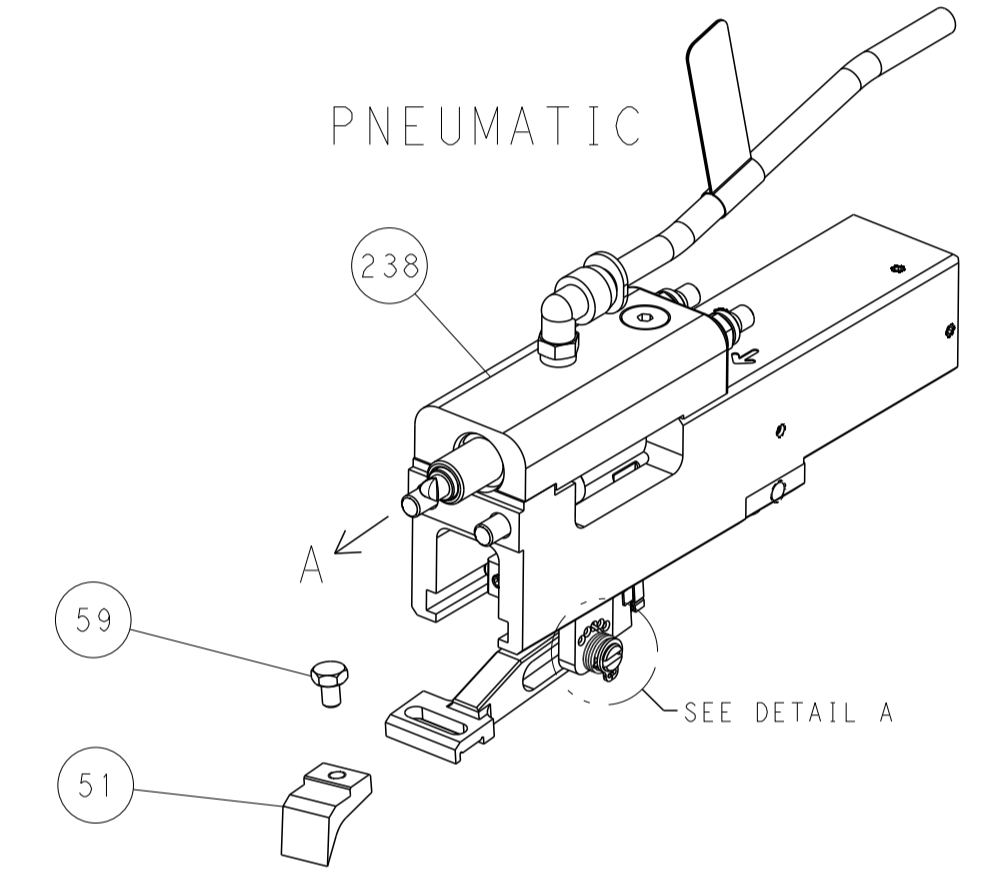

FEED SPRING  
 SETTING POSITION

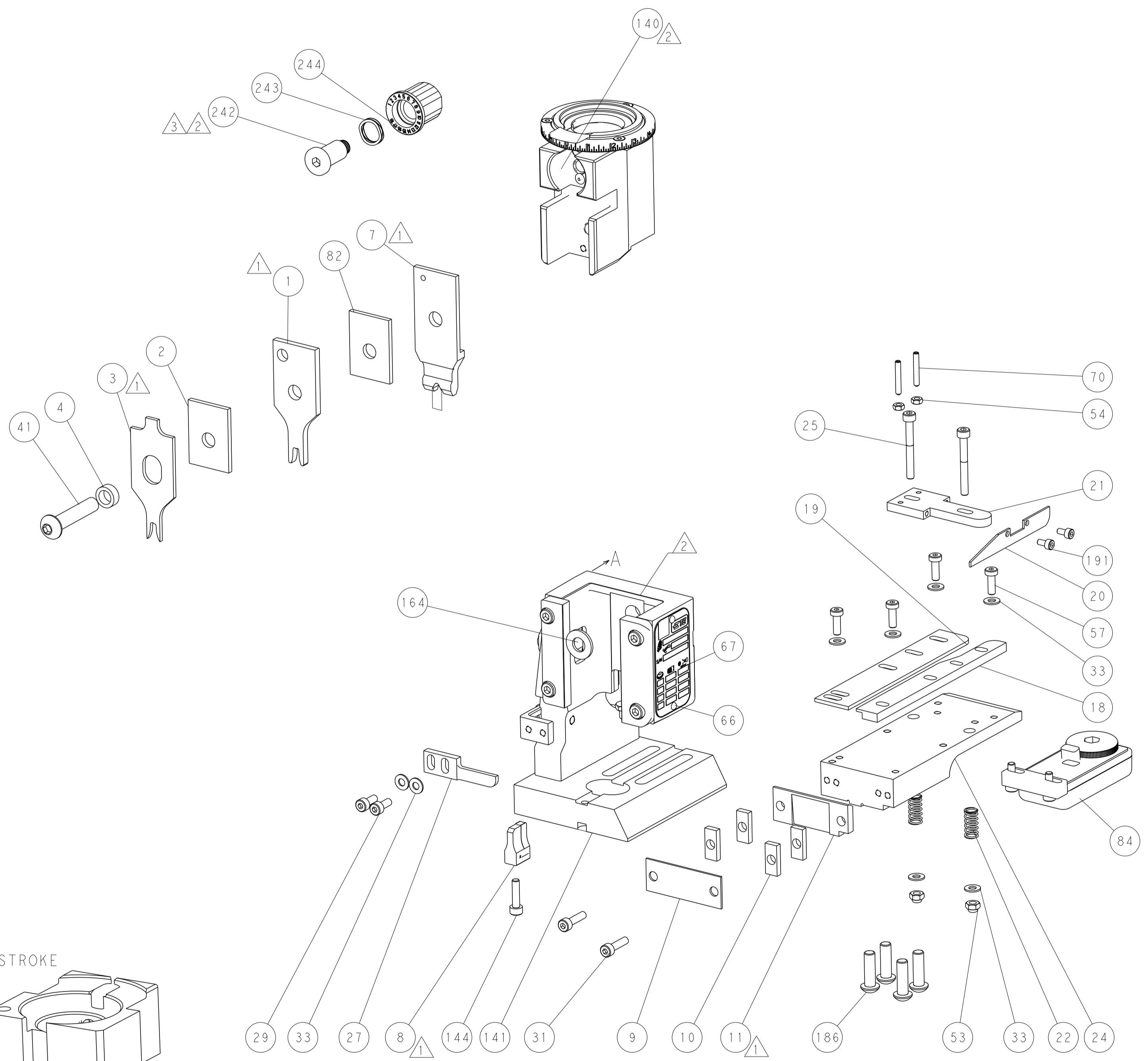
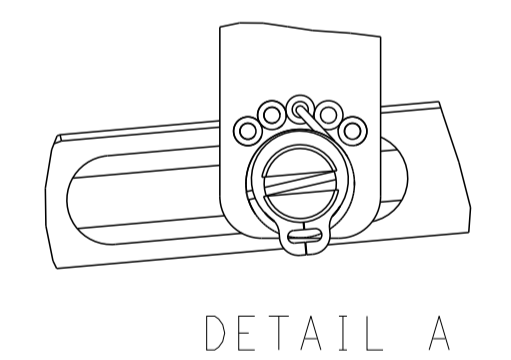

CAM POSITIONS

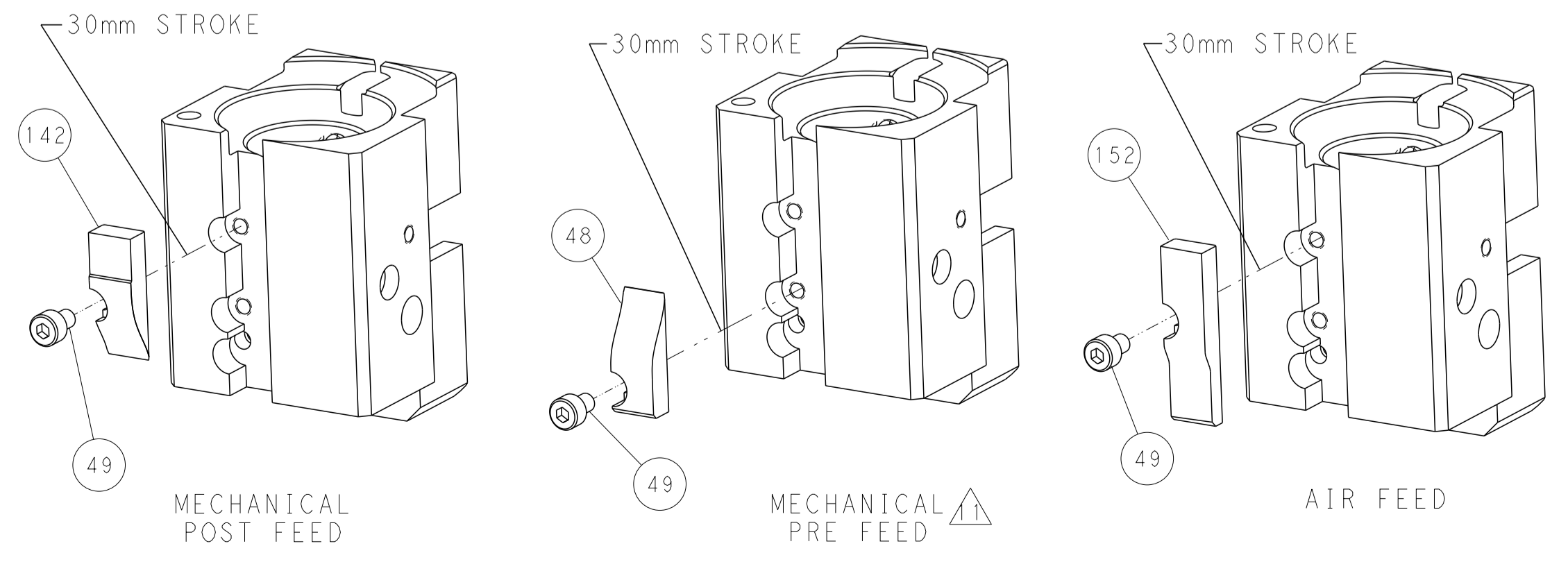

PACIFIC VERSION  
 Shown on sheets 3 of 4 & 4 of 4  
 (Atlantic version shown on sheets 1 of 4 & 2 of 4)

DIMENSIONS: mm 		TOLERANCES UNLESS OTHERWISE SPECIFIED: 0 PLC ± 1 PLC ± 2 PLC ± 3 PLC ± 4 PLC ± ANGLES ± FINISH		DWN: K. STAKEM 30JUNE2014 CHK: G. BAILEY 30JUNE2014 APVD: T. ERLIN 30JUNE2014 PRODUCT SPEC APPLICATION SPEC WEIGHT Customer Accessible Production Drawing		NAME: Ocean End Feed Applicator SIZE: A1 CAGE CODE: 00779 DRAWING NO: C-2150449 SCALE: 1:1 SHEET: 4 of 4 REV: C	
MATERIAL:				RESTRICTED TO:			