

PRODUCT NUMBER	DESCRIPTION	NOTES
10124464-XXXXHLF	HALOGEN FREE (H)	SEE SHT. 3

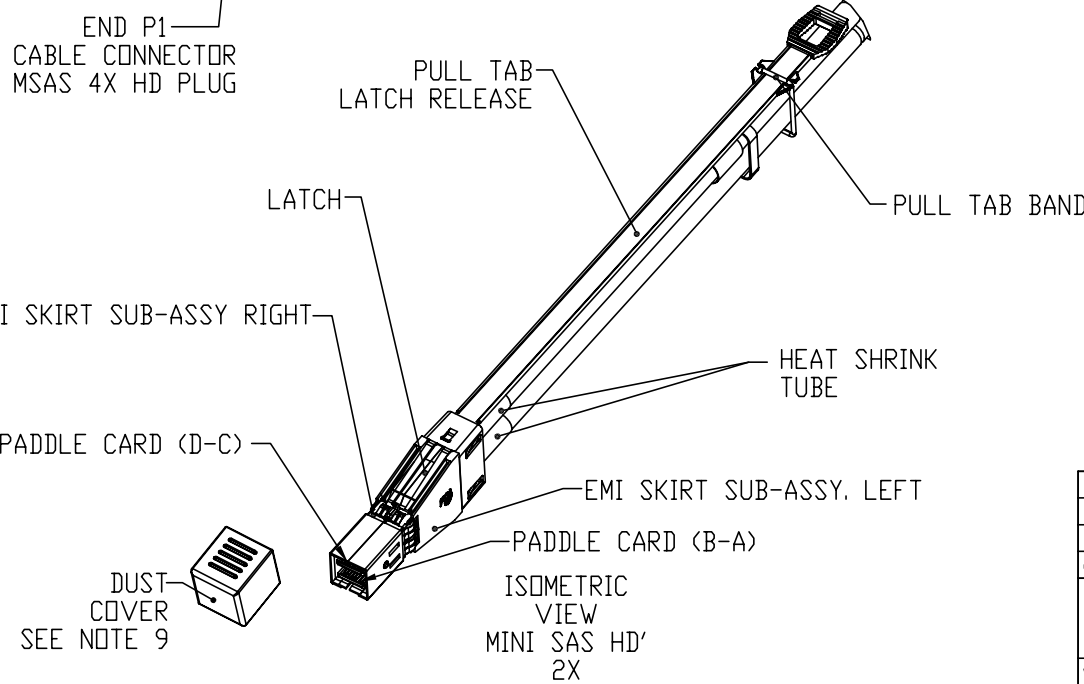

dr	TOMMY LIN	2013-04-01	projection	mm	size	A3	scale	1:2	
eng	TOMMY LIN	2013-04-01			ecn no				
chr	TOMMY LIN	2013-04-01	product family	C&A	rel level				
appr	ROGER CHENG	2013-04-01							
www.fci.com			title	FINAL ASSEMBLY (PASSIVE) MSAS HD 4X ASSEMBLY (12 Gb/s)		dwg no	10124464	rev	A
			cat. no.	-	Product - Customer Drw		sheet 1 of 3		

PRODUCT NUMBER	DESCRIPTION	NOTES
10124464-XXXXHLF	HALOGEN FREE (H)	SEE SHT. 3

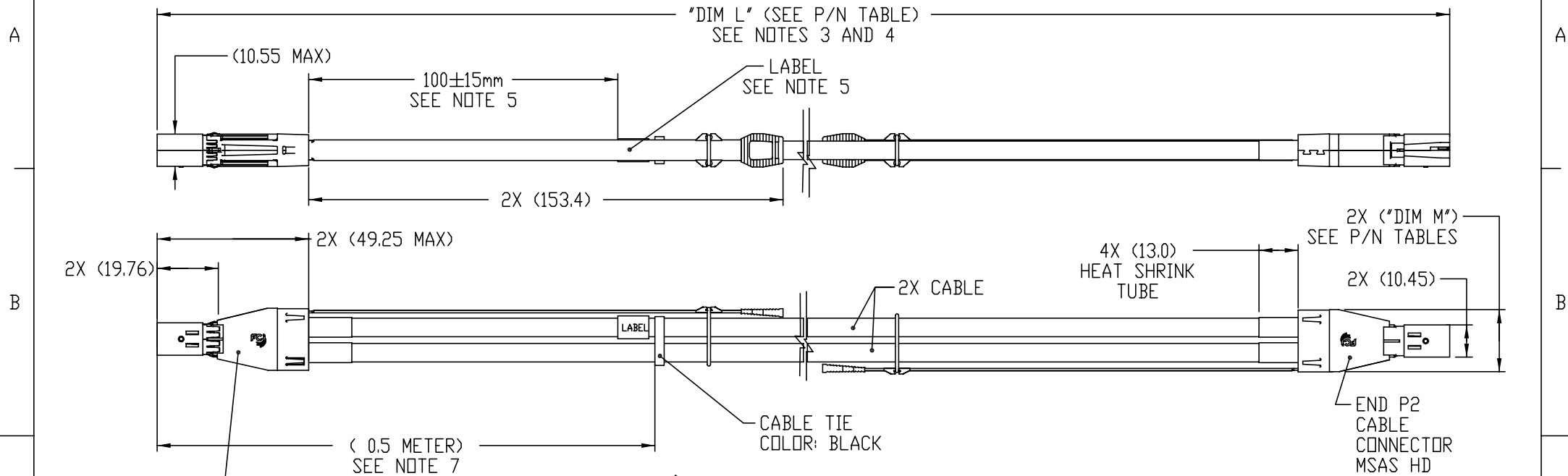
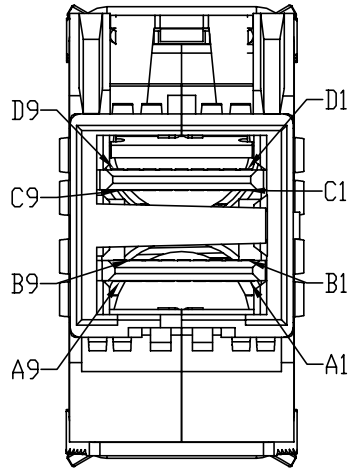

P1
VIEW A
SCALE 4:1

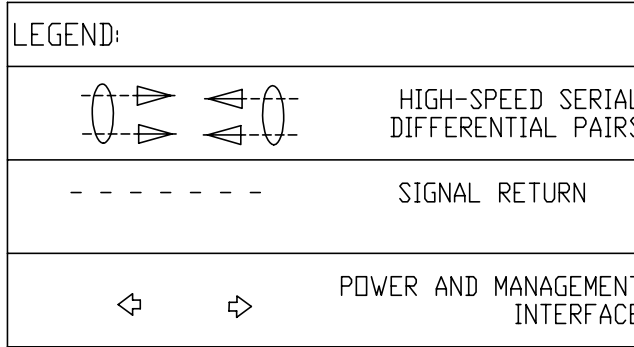

CABLE	A	B	C	D (nominal)	("DIM Y") NON-HF
24 AWG	29.5	13.0	50.28	∅ 8.38	92.78
26 AWG			42.6	∅ 7.1	85.1
28 AWG			36.6	∅ 6.1	79.1
30 AWG			31.8	∅ 5.3	74.3

CABLE	A	B	C	D (nominal)	("DIM Y") HF
24 AWG	29.5	13.0	50.28	∅ 8.38	92.78
26 AWG			45	∅ 7.5	87.5
28 AWG			39	∅ 6.5	81.5
30 AWG			35.4	∅ 5.9	77.9

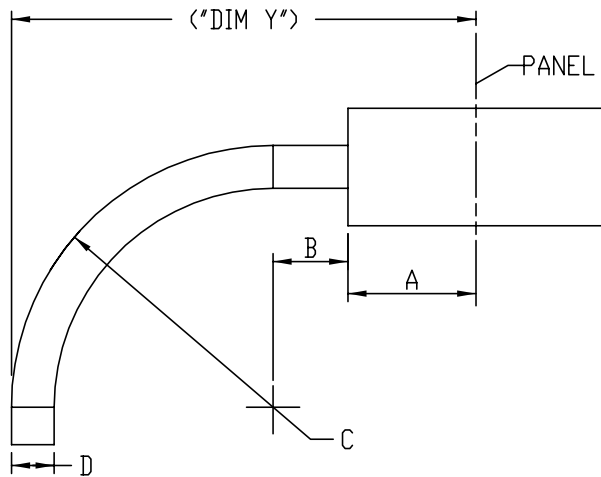

BEND RADIUS
TOP VIEW OF CONNECTOR

END P1		END P2	
POSITION	SYMBOL	POSITION	SYMBOL
D9	GROUND	B9	GROUND
D8	Tx2-	B8	Rx2-
D7	Tx2+	B7	Rx2+
D6	GROUND	B6	GROUND
D5	Tx0-	B5	Rx0-
D4	Tx0+	B4	Rx0+
D3	GROUND	B3	GROUND
D2	Vman	B2	ModPrsL
D1	Vact	B1	Vact
C1	SCL	A1	Reserved
C2	SDA	A2	IntL
C3	GROUND	A3	GROUND
C4	Tx1+	A4	Rx1+
C5	Tx1-	A5	Rx1-
C6	GROUND	A6	GROUND
C7	Tx3+	A7	Rx3+
C8	Tx3-	A8	Rx3-
C9	GROUND	A9	GROUND
B9	GROUND	D9	GROUND
B8	Rx2-	D8	Tx2-
B7	Rx2+	D7	Tx2+
B6	GROUND	D6	GROUND
B5	Rx0-	D5	Tx0-
B4	Rx0+	D4	Tx0+
B3	GROUND	D3	GROUND
B2	ModPrsL	D2	Vman
B1	Vact	D1	Vact
A1	Reserved	C1	SCL
A2	IntL	C2	SDA
A3	GROUND	C3	GROUND
A4	Rx1+	C4	Tx1+
A5	Rx1-	C5	Tx1-
A6	GROUND	C6	GROUND
A7	Rx3+	C7	Tx3+
A8	Rx3-	C8	Tx3-
A9	GROUND	C9	GROUND

SHIELD-----SHIELD

dr	TOMMY LIN	2013-04-01	projection	mm	size	A3	scale	1:2
eng	TOMMY LIN	2013-04-01			ecn no			
chr	TOMMY LIN	2013-04-01			product family		C&A	
appr	ROGER CHENG	2013-04-01	product family		C&A		rel level	
			FINAL ASSEMBLY (PASSIVE)			dwg no 10124464		rev A
www.fci.com cat. no.			MSAS HD 4X ASSEMBLY (12 Gb/s)			Product - Customer Drw sheet 2 of 3		

PART NUMBER (HALOGEN FREE) SEE NOTE 11	"DIM L" LENGTH (Meters)	"DIM M" (mm)	AWG
10124464-2008HLF	0.75	17.3	30

NOTES CONTINUED:

10. A "△" SYMBOL WILL BE NEXT TO ANY DIMENSION, VIEW, OR NOTE WHICH HAS BEEN MODIFIED WITH THE CURRENT DRAWING REVISION. THE CURRENT REVISION WILL BE SHOWN IN THE SYMBOL.

- ① "H" PRODUCT NUMBERS DESIGNATE THE USE OF HALOGEN FREE RAW CABLE.
- ② HALOGEN FREE RAW CABLE CAN BE USED AS A SUBSTITUTE ON NON-HF PRODUCT NUMBERS.

13. MEETS ELECTRICAL PERFORMANCE REQUIREMENTS OF SAS 2.1

14. MATES TO SERIES: 10112626 or 10112627 Or 10112628

NOTES:

- 1. MATERIAL:
BACK SHELLS: ZINC ALLOY/ COPPER UNDERPLATE/ NICKEL OVERPLATE
PULL TAB: THERMOPLASTIC POLYMER
LATCH : STAINLESS STEEL
FERRULE: BRASS
EMI SKIRT: STAINLESS STEEL
LOCTITE
PADDLE CARD: PRINTED CIRCUIT SUBSTRATE
HEAT SHRINK TUBE: POLYOLEFIN
- 2. THIS PRODUCT MEETS THE RESTRICTION OF HAZARDOUS SUBSTANCES IN ELECTRICAL AND ELECTRONIC EQUIPMENT (RoHS) DIRECTIVE (2002/95/EC)

- ③ THIS DIMENSION IS A FINISHED PRODUCT LENGTH.
- ④ UNLESS OTHERWISE SPECIFIED ASSEMBLED LENGTH TOLERANCE IS TO BE:
"DIM L" < 1 METER = ±25mm
"DIM L" 1 METER TO 10 METERS = ±2% OF "DIM L"

- ⑤ LABEL DETAILS:
MANUFACTURER CODE OR NAME COUNTRY OF ORIGIN
CUSTOMER P/N OR FCI P/N
CUSTOMER DRAWING REVISION
SERIAL NUMBER

LABEL EXAMPLE

FCI	MADE IN CHINA
10124464-2008HLF	
REV.A	
CN1312HV0A2H0001	

FONT SHALL BE CLEARLY VISIBLE AND BLACK IN COLOR. SERIAL NUMBER IS ONLY USED FOR TRACKING PRODUCT,DETAIL IS AS BELOW :

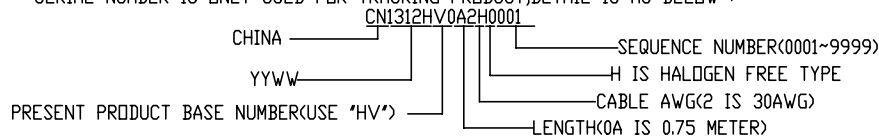

- ⑥ ALL CABLE ASSEMBLIES 100% TESTED FOR CONTINUITY AS DEFINED IN WIRING LIST.
 - 7. PLACE A CABLE TIE EVERY 0.5 METER ON ALL ASSEMBLIES, UNLESS OTHERWISE SPECIFIED. IN CASE OF 0.5 METER CABLE ASSEMBLY, CABLE TIE IS TO BE APPLIED AT THE MIDWAY POINT.
 - 8. OTHER TESTING PERFORMED AS REQUIRED BY PRODUCT SPECIFICATION: GS-12-651.
 - ⑨ PACKAGING OF LEAD FREE PRODUCTS MEETS LABELING AND PACKAGING PER SPECIFICATION GS-14-920. PACKAGE CABLE ASSEMBLIES PER GS-14-2314.
- DUST COVERS ARE TO BE ASSEMBLED PRIOR TO PACKAGING.

dr	TOMMY LIN	2013-04-01	projection	mm	size	A3	scale	1:2		
eng	TOMMY LIN	2013-04-01			ecn no					
chr	TOMMY LIN	2013-04-01	product family	C&A	rel level					
appr	ROGER CHENG	2013-04-01								
FCI		title			FINAL ASSEMBLY (PASSIVE)		dwg no	10124464	rev	A
www.fci.com		cat. no.			-		Product - Customer Drw		sheet 3 of 3	

