

ATLANTIC VERSION TERMINATOR INTERFACE ADAPTER	PART NUMBER	REVISION	DESCRIPTION	FEED TYPE	APPLICATOR STYLE CONVERSION CHART						
					CONVERT TO	PART NUMBERS REQUIRED					
	2150516-2	A	FINE CRIMP HEIGHT ADJUST	PNEUMATIC	-	-	-	-	-	-	
					SERVO LATCH PLATE	2119951-1	1901697-1	8-2150516-5	-	-	2168400-7 (QUANTITY 2)
					SMART APPLICATOR	2161326-1	-	8-2150516-4	-	-	-
	2150516-5	A	FINE CRIMP HEIGHT ADJUST	SERVO LATCH PLATE ⁴	PNEUMATIC FEED	2119950-1	2119792-2	-	2119641-1	-	2063440-1
	2150516-6	A	NON-CRIMP HEIGHT ADJUST	SERVO LATCH PLATE ⁴	-	-	-	-	-	-	-
	2150516-7	A	FINE CRIMP HEIGHT ADJUST	NONE	-	-	-	-	-	-	-
	7-2150516-7	A	CRIMP TOOLING KIT	-	-	-	-	-	-	-	-

APPLICATOR DATA		
CRIMP	SIZE	TYPE
WIRE	2.29 mm [.090]	F
INSUL	3.56 mm [.140]	F
APPL INSTRUCTIONS 408-10390		

TERMINAL DATA: TE TERMINAL TE CRIMP SPECIFICATION			
TERMINAL NAME: .180 DIA. SHUR PLUG			
WIRE STRIP LENGTH		INSULATION DIAMETER RANGE	
4.39-5.16 mm [.173-.203 IN]		∅2.29-3.18 mm [.090-.125 IN]	
TERMINAL APPLICATION SPECIFICATION		114-2017	-
TERMINALS APPLIED ¹⁰			
TE TERMINAL	TE TERMINAL	TE TERMINAL	TE TERMINAL
505038-1			

WIRE SIZE	CRIMP HEIGHT mm [INCH]	CRIMP HEIGHT REFERENCE SETTING ⁹
16 AWG	1.83 +/- 0.05 [.072 +/- .002]	6.8
18 AWG	1.65 +/- 0.05 [.065 +/- .002]	8.6
20 AWG	1.55 +/- 0.05 [.061 +/- .002]	9.7

- ¹ RECOMMENDED SPARE PARTS
- ² GREASE BEARING SURFACES LIGHTLY
- 3. LUBRICATE DAILY PER THE APPLICATOR INSTRUCTION SHEET SUPPLIED WITH THE APPLICATOR.
- ⁴ APPLICATOR SPECIFIC DATA TO BE ENTERED INTO BLANK MEMORY CHIP AT ASSEMBLY. SEE BELOW FOR PART NUMBER:
 PNEUMATIC FEED WITH "SMART APPLICATOR" CONVERSION: 8-2150516-4
 SERVO FEED WITH "FINE CRIMP HEIGHT ADJUST": 8-2150516-5
 SERVO FEED WITH "NON-CRIMP HEIGHT ADJUST": 8-2150516-6
- 5. ADJUSTMENT OF THE STRIPPER MAY BE REQUIRED WHEN MOVING THE APPLICATOR BETWEEN BENCH AND LEADMAKER APPLICATIONS.
- ⁶ APPLY PART NUMBER 1-23419-5 LOCTITE TO THREADS OF ITEMS 62 & 180. APPLY PART NUMBER 2-23419-6 LOCTITE TO THREADS OF ITEM 242. FOR -6 ONLY APPLY PART NUMBER 1-23419-5 LOCTITE TO THREADS OF ITEMS 37 & 180.
- ⁷ GREASE THREADS, GROOVE AND O-RING ON ITEMS 35 & 252.
- ⁸ MAGNET, ITEM 166 MUST BE ORIENTED CORRECTLY IN ORDER TO PROPERLY ACTUATE THE COUNTER.
- ⁹ CRIMP HEIGHT REFERENCE SETTING WAS THE SETTING USED WHEN THE APPLICATOR WAS QUALIFIED AT THE FACTORY. ADJUSTMENT MAY BE NECESSARY WHEN RUNNING APPLICATOR IN THE FIELD.
- ¹⁰ TERMINAL PITCH IS NOT COMPATIBLE WITH MECHANICAL FEED.
- ¹¹ THE RECOMMENDED SET-UP FOR END FEED APPLICATORS IS POST-FEED WITH ITEM 2119653-1. THE APPLICATOR CAN BE CONFIGURED FOR PRE-FEED WITH ITEM 2119652-1 BUT MAY ENCOUNTER PROBLEMS WITH SOME APPLICATIONS. FEED ISSUES OR TERMINAL JAMMING MAY OCCUR IN THE PRE-FEED CONFIGURATION.
- ¹² WHEN ASSEMBLING -6 NON-CRIMP HEIGHT ADJUST APPLICATOR USE SHIM PACK 2119957-2 TO ALIGN APPLICATOR'S MAXIMUM WIRE CRIMP HEIGHT AT NORMAL TERMINATOR SHUT HEIGHT

***WARNING**
 ON INSTALLATION, SET WIRE DISC, ITEM 40 TO LARGEST WIRE SIZE SETTING. USE OF SETTINGS BELOW MINIMUM REQUIRED CRIMP HEIGHT SETTING WILL CAUSE DAMAGE TO CRIMP TOOLING.

-	-	1	-	-	2119957-2	APPLICATOR SHIM PACK	260
-	1	-	1	1	8-21084-0	O-RING, .676 ID, .070 DIA. MAT.	252
-	-	-	-	1	2119640-1	PUSH ROD, AIR FEED	250
-	-	-	-	1	2079988-1	BUSHING, LCH5-12, MISUMI	249
-	-	-	-	1	2119641-1	FEED CAM, AIR FEED	248
-77	-7	-6	-5	-2	PART NO	DESCRIPTION	ITEM NO

ATLANTIC VERSION
 Shown on sheets 1 of 4 & 2 of 4
 (Pacific version shown on sheets 3 of 4 & 4 of 4)

SET UP GAUGE	LOC	DIST	REVISIONS					
2119599-2	A	66	P	LTM	DESCRIPTION	DATE	OWN	APVD
			A		RELEASED	18FEB2015	RK	GB

-	1	-	1	1	2119798-1	DETENT PIN	247
-	1	-	1	1	1-22279-3	SPRING, COMPRESSION	246
-	-	1	-	-	2119759-1	RAM, AMP STYLE, END FEED, NON-ADJUST	245
-	1	1	1	1	2119082-2	CAM, SNAIL, INSULATION ADJUSTMENT	244
-	1	1	1	1	2079764-1	WASHER, WAVE SPRING, CREST-TO-CREST	243
-	1	1	1	1	2119083-1	RETAINER, INSULATION DIAL	242
-	-	2	2	-	2168400-7	SHCS, LOW HEAD, RoHS, M5 X 10	240
-	-	-	-	1	2063440-1	AIR FEED MODULE	238
-	-	1	1	-	2119740-2	TAG, IDENTIFICATION	213
-	-	REFREF	-	-	1901697-1	FEED FINGER ASSEMBLY, EF	183
-	1	1	1	1	1-1752354-7	STANDOFF, HOLD-DOWN	180
-	1	1	1	1	6-993111-6	PIN, SLOTTED SPRING 3.0 X 14.0	177
-	1	1	1	1	8-22280-7	SPRING, COMPRESSION	176
-	1	1	1	1	1752353-2	GUIDE PIN, HOLDDOWN	175
-	1	1	1	1	1901680-2	GUIDE PIN, HOLDDOWN	174
-	-	-	-	2	21045-3	RING, RETAIN, EXTERN, 3/16 CRESCENT	172
-	1	1	1	1	994969-1	MAGNET, RARE EARTH HIGH ENERGY	166
-	REFREF	REFREF	REFREF	REFREF	994970-2	COUNTER, MAGNETIC	164
-	-	-	-	1	240638-1	SPRING, FEED FINGER	163
-	-	-	-	1	3-23627-7	PIN, RETAIN, GRVD, 3/16 X .854	137
-	-	REFREF	-	-	SEE NOTE 4	MEMORY CHIP, PROGRAMMED	135
-	-	1	1	-	1633743-1	SERVO FEED LATCH ASM	133
-	1	1	1	1	455888-4	SPACER, CRIMPER	82
-	1	1	1	1	2119791-5	DEPRESSOR, WIRE	73
-	1	1	1	1	2119956-2	DOCUMENTATION PACKAGE	71
-	2	2	2	2	2-18032-2	SCR, SET, FLT POINT M3 X 10.0	70
-	1	1	1	1	2119943-1	WASHER, SPACER	69
-	1	-	-	1	2119740-1	TAG, IDENTIFICATION	67
-	2	2	2	2	2168078-1	SCREW, DRIVE, RH, RoHS, 2 x .188	66
-	1	1	1	1	1901681-1	HOLDDOWN, TERMINAL	65
-	2	2	2	2	2168400-5	SHCS, LOW HEAD, RoHS, M4 X 20	64
-	1	-	1	1	2119793-1	LIMITER, ADJUSTMENT BOLT	63
-	3	-	3	3	992763-5	SCR, SET, SOC, CONE POINT, M3 x 4.0	62
-	1	1	1	1	2079383-4	SCR, BHSC, RoHS (M4 X 8)	60
-	3	3	3	3	2168400-4	SHCS, LOW HEAD, RoHS, M4 X 8	57
-	2	2	2	2	2168083-3	SCR, SKT HD CAP, RoHS, M4 X 12.0	56
-	2	2	2	2	5018030-2	NUT, HEX, REG, RoHS, M4	55
-	2	2	2	2	5018030-1	NUT, HEX, REG, RoHS, M3	54
-	2	2	2	2	986965-8	NUT, LOCK, HEX, TORQUE (M4)	53
-	1	1	1	1	1-5018030-0	NUT, HEX, REG, RoHS, M3.5	52
-	-	-	-	1	2119792-2	PAWL, EF, AIR	51
-	-	-	-	1	18023-9	SCR, SKT HD CAP M4 X 6.0	49
-	1	1	1	1	2119655-5	APPLICATOR BASIC ASSEMBLY, EF	46
-	1	-	1	1	2119369-1	RAM, AMP STYLE, END FEED	44
-	1	1	1	1	2079383-7	SCR, BHSC, RoHS (M8 X 25)	41
-	1	-	1	1	2119645-1	DISC, NUMBERED FA WIRE ADJUSTMENT	40
-	1	-	1	1	2119957-1	APPLICATOR SHIM PACK	39
-	1	1	1	1	2119644-3	RAM WASHER, PRECISION	38
-	1	1	1	1	2119085-1	FA HEAD, ATLANTIC STYLE	37
-	1	-	1	1	2119092-1	BOLT, ADJUSTMENT	35
-	7	7	7	7	1-18028-2	WASHER, FLAT, REG M4	33
-	2	2	2	2	2168083-9	SCR, SKT HD CAP, RoHS, M4 X 20	31
-	2	2	2	2	1-2168083-0	SCR, SKT HD CAP, RoHS, M4 X 10	29
-	1	1	1	1	240639-1	STRIPPER (MACHINING)	27
-	2	2	2	2	1320906-1	STUD, THREADED	25
-	1	1	1	1	1-1752371-2	PLATE, STRIP GUIDE	24
-	1	1	1	1	240825-1	PLATE, STRIP HOLD DOWN	23
-	2	2	2	2	2-22281-3	SPRING, COMPRESSION	22
-	1	1	1	1	1752373-4	DRAG	20
-	2	2	2	2	1901259-5	GUIDE, LOWER STRIP	18
-	4	4	4	4	1-2079383-1	SCR, BHSC, RoHS (M6 X 12)	17
-	1	1	1	1	1752360-1	SPACER, HOLD-DOWN	13
-	1	1	1	1	240644-5	PLATE, REAR SHEAR	11
-	-	-	-	-	-	-	10
-	1	1	1	1	2-690496-6	PLATE, FRONT SHEAR	9
-	1	1	1	1	1-1803059-8	ANVIL, COMBINATION, END FEED	8
-	1	1	1	1	1-2217206-0	BLADE, SLUG	7
-	-	-	-	-	-	-	6
-	1	1	1	1	1-240641-5	SPACER	5
-	1	1	1	1	238009-8	BLOCK, FL CRIMPER SPACER	4
-	1	1	1	1	3-1633961-0	CRIMPER, INSULATION F PREMIUM	3
-	1	1	1	1	455888-1	SPACER, CRIMPER	2
-	1	1	1	1	1-456406-5	CRIMPER, WIRE PREMIUM	1
-77	-7	-6	-5	-2	PART NO	DESCRIPTION	ITEM NO

DIMENSIONS:		TOLERANCES UNLESS OTHERWISE SPECIFIED:		DATE		NAME	
mm	0 PLC ±.5	1 PLC ±0.5	2 PLC ±0.13	3 PLC ±0.013	4 PLC ±0.0001	APVD	DATE
	ANGLES ±.0001	FINISH					
MATERIAL		WEIGHT		SCALE		SHEET	OF
				1:1		1	4

STE TE Connectivity
 Harrisburg, PA 17105-3608

Ocean End Feed
 Applicator

Customer Accessible Production Drawing

LOC		DIST		REVISIONS			
A	66	P	LTM	DESCRIPTION	DATE	OWN	APVD
		-		SEE SHEET 1			

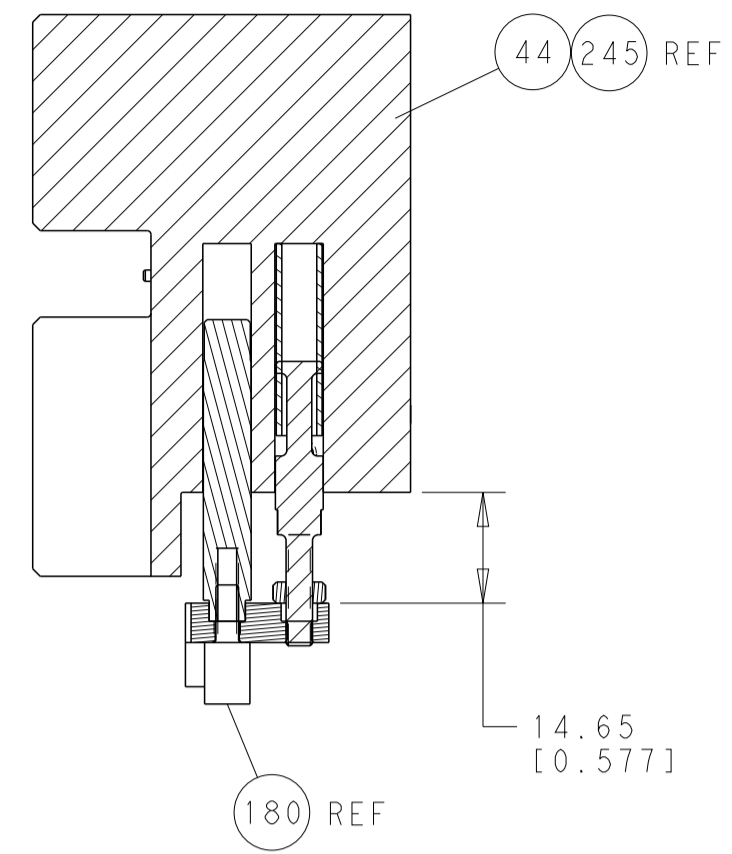

HOLDDOWN SET-UP

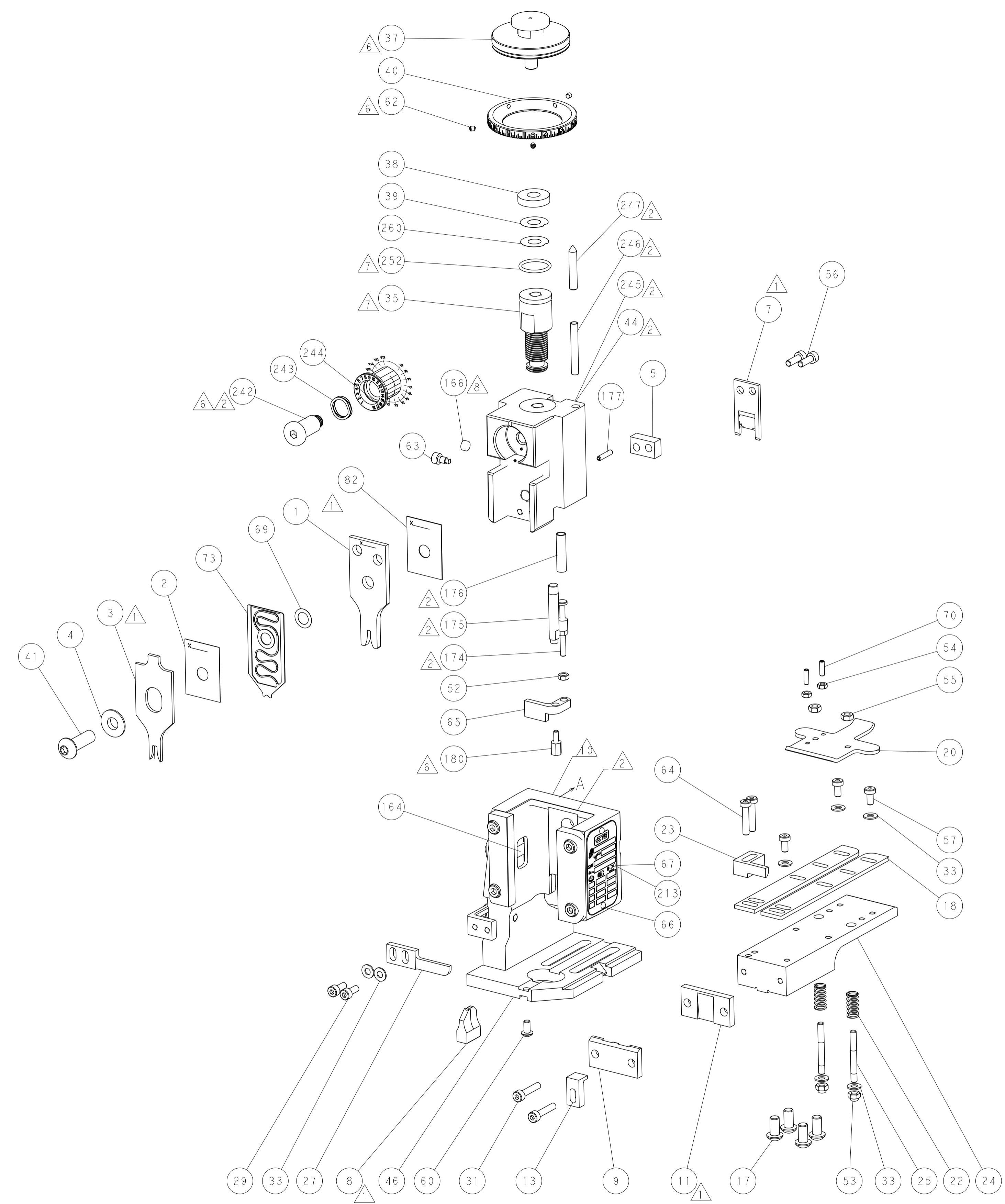

FEED TYPE
PNEUMATIC

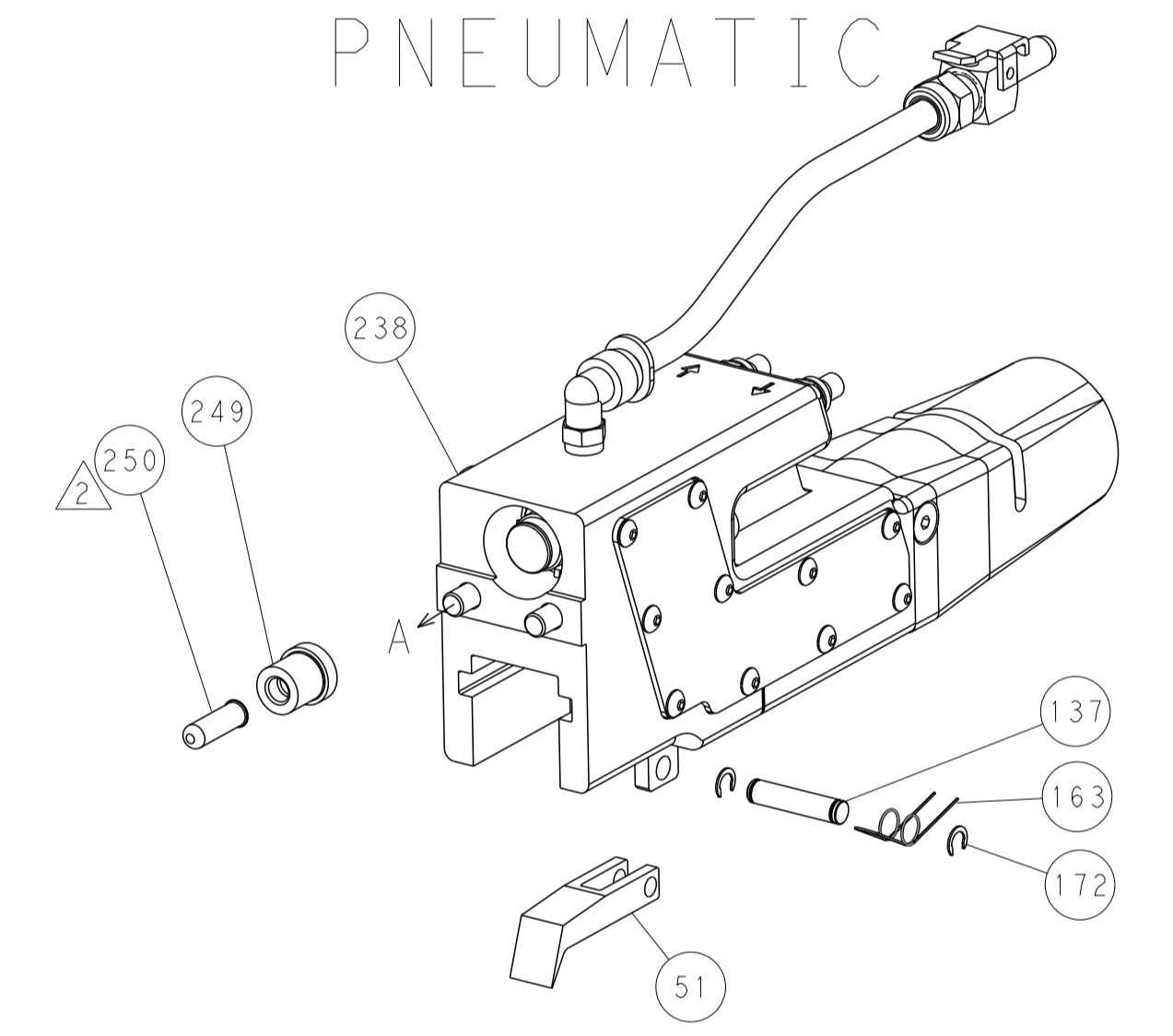

SERVO
LATCH PLATE

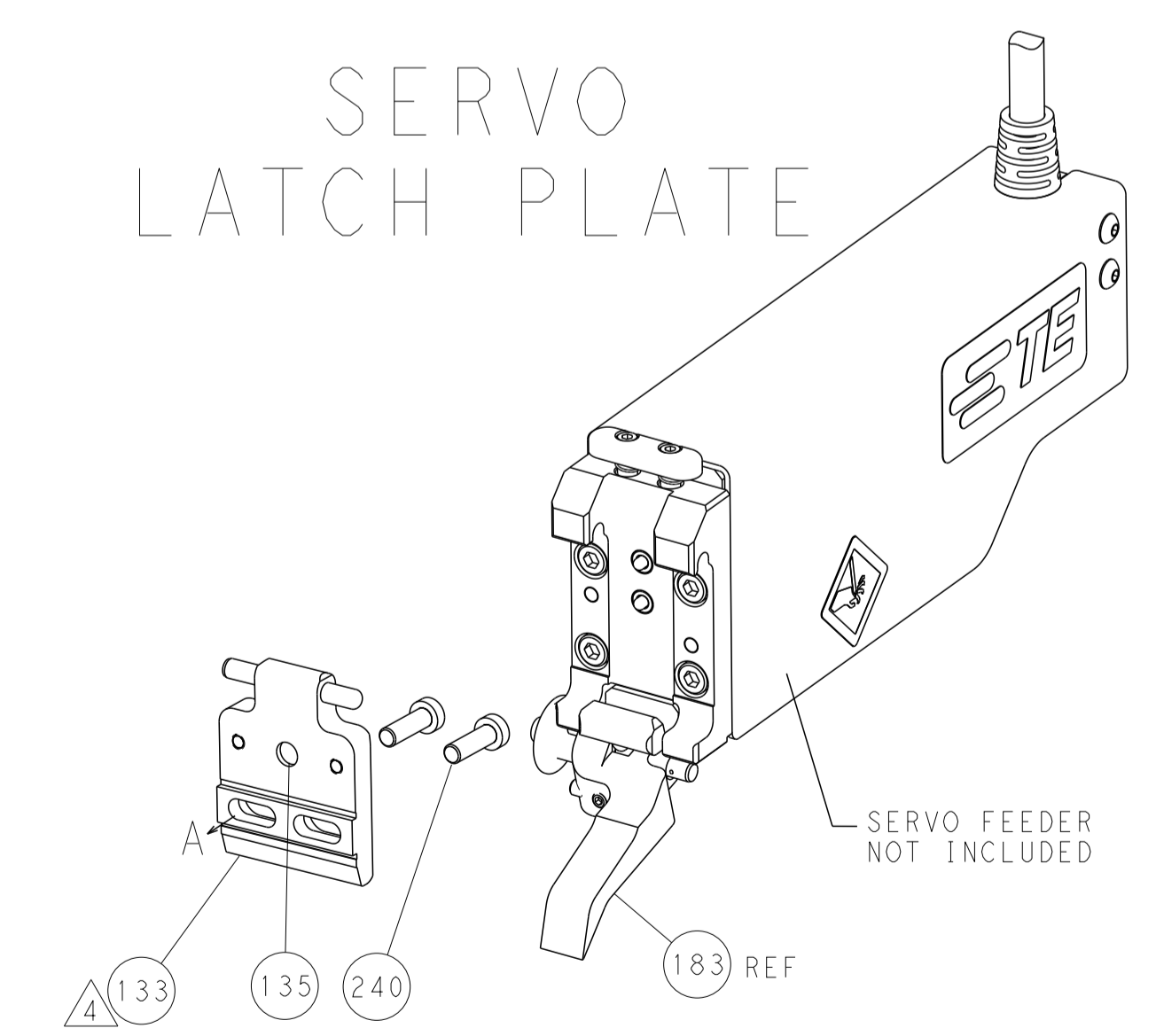

CAM POSITION

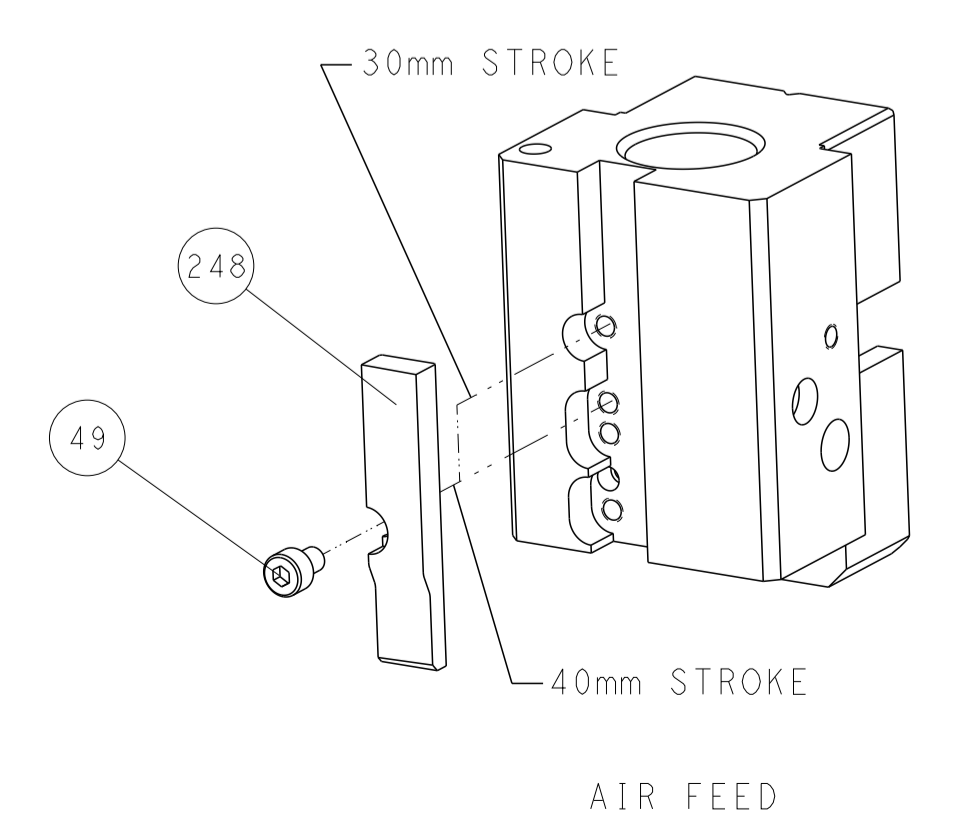

AIR FEED

ATLANTIC VERSION
 Shown on sheets 1 of 4 & 2 of 4
 (Pacific version shown on sheets 3 of 4 & 4 of 4)

DIMENSIONS: mm 		TOLERANCES UNLESS OTHERWISE SPECIFIED: 0 PLC ±.5 1 PLC ±0.5 2 PLC ±0.13 3 PLC ±0.013 4 PLC ±0.001 ANGLES ±.1		DWN K. HUANG 05JAN2015 CHK L. ZHANG 05JAN2015 APVD J. GUO 05JAN2015		TE Connectivity Harrisburg, PA 17105-3608	
MATERIAL:		FINISH:		NAME: Ocean End Feed Applicator		SIZE: CAGE CODE: DRAWING NO: RESTRICTED TO:	
WEIGHT:		SCALE: 1:1		SHEET 2 OF 4		REV A	

PACIFIC VERSION TERMINATOR INTERFACE ADAPTER	PART NUMBER	REVISION	DESCRIPTION	FEED TYPE	APPLICATOR STYLE CONVERSION CHART						
					CONVERT TO	PART NUMBERS REQUIRED					
	2-2150516-2	A	FINE CRIMP HEIGHT ADJUST	PNEUMATIC	-	-	-	-	-	-	
	2-2150516-5	A	FINE CRIMP HEIGHT ADJUST	SERVO LATCH PLATE	SERVO LATCH PLATE	2119951-1	1901697-1	8-2150516-5	-	-	2168400-7 (QUANTITY 2)
					SMART APPLICATOR	2161326-1	-	8-2150516-4	-	-	-
	2-2150516-7	A	FINE CRIMP HEIGHT ADJUST	NONE	-	-	-	-	-	-	
7-2150516-7	A	CRIMP TOOLING KIT	-	-	-	-	-	-	-	-	

APPLICATOR DATA		
CRIMP	SIZE	TYPE
WIRE	2.29 mm [.090]	F
INSUL	3.56 mm [1.40]	F
APPL INSTRUCTIONS 408-10390		

TERMINAL DATA: TE TERMINAL		TE CRIMP SPECIFICATION
TERMINAL NAME: .180 DIA. SHUR PLUG		
WIRE STRIP LENGTH		INSULATION DIAMETER RANGE
4.39-5.16 mm [1.73-.203 IN]		∅2.29-3.18 mm [1.090-.125 IN]
TERMINAL APPLICATION SPECIFICATION	114-2017	-
TERMINALS APPLIED		
TE TERMINAL	TE TERMINAL	TE TERMINAL
505038-1		

WIRE SIZE	CRIMP HEIGHT mm [INCH]	CRIMP HEIGHT REFERENCE SETTING
16 AWG	1.83 +/- 0.05 [1.072 +/- .002]	6.8
18 AWG	1.65 +/- 0.05 [1.065 +/- .002]	8.6
20 AWG	1.55 +/- 0.05 [1.061 +/- .002]	9.7

- RECOMMENDED SPARE PARTS
- GREASE BEARING SURFACES LIGHTLY
- 3. LUBRICATE DAILY PER THE APPLICATOR INSTRUCTION SHEET SUPPLIED WITH THE APPLICATOR.
- APPLICATOR SPECIFIC DATA TO BE ENTERED INTO BLANK MEMORY CHIP AT ASSEMBLY. SEE BELOW FOR PART NUMBER:
 PNEUMATIC FEED WITH "SMART APPLICATOR" CONVERSION: 8-2150516-4
 SERVO FEED WITH "FINE CRIMP HEIGHT ADJUST": 8-2150516-5
- 5. ADJUSTMENT OF THE STRIPPER MAY BE REQUIRED WHEN MOVING THE APPLICATOR BETWEEN BENCH AND LEADMAKER APPLICATIONS.
- APPLY PART NUMBER 1-23419-5 LOCTITE TO THREADS OF ITEMS 62 & 180. APPLY PART NUMBER 2-23419-6 LOCTITE TO THREADS OF ITEM 242.
- GREASE THREADS, GROOVE AND O-RING ON ITEMS 139 & 153.
- MAGNET, ITEM 166 MUST BE ORIENTED CORRECTLY IN ORDER TO PROPERLY ACTUATE THE COUNTER.
- CRIMP HEIGHT REFERENCE SETTING WAS THE SETTING USED WHEN THE APPLICATOR WAS QUALIFIED AT THE FACTORY. ADJUSTMENT MAY BE NECESSARY WHEN RUNNING APPLICATOR IN THE FIELD.
- TERMINAL PITCH IS NOT COMPATIBLE WITH MECHANICAL FEED.
- THE RECOMMENDED SET-UP FOR END FEED APPLICATORS IS POST-FEED WITH ITEM 2119653-1. THE APPLICATOR CAN BE CONFIGURED FOR PRE-FEED WITH ITEM 2119652-1 BUT MAY ENCOUNTER PROBLEMS WITH SOME APPLICATIONS. FEED ISSUES OR TERMINAL JAMMING MAY OCCUR IN THE PRE-FEED CONFIGURATION.

***WARNING**
 ON INSTALLATION, SET WIRE DISC, ITEM 40 TO LARGEST WIRE SIZE SETTING. USE OF SETTINGS BELOW MINIMUM REQUIRED CRIMP HEIGHT SETTING WILL CAUSE DAMAGE TO CRIMP TOOLING.

- 1 1 1	2119782-1	FINE ADJUST HEAD ASM, PACIFIC STYLE	251
- - - 1	2119640-1	PUSH ROD, AIR FEED	250
- - - 1	2079988-1	BUSHING, LCH5-12, MISUMI	249
- 77-27-25-22	PART NO	DESCRIPTION	ITEM NO

PACIFIC VERSION
 Shown on sheets 3 of 4 & 4 of 4
 (Atlantic version shown on sheets 1 of 4 & 2 of 4)

SET UP GAUGE	LOC	DIST	REVISIONS			
2119599-2	A	66	REV	DATE	BY	APPV
			-	SEE SHEET 1	-	-

- 1 1 1	1-22279-3	SPRING, COMPRESSION	246
- 1 1 1	2119082-2	CAM, SNAIL, INSULATION ADJUSTMENT	244
- 1 1 1	2079764-1	WASHER, WAVE SPRING, CREST-TO-CREST	243
- 1 1 1	2119083-1	RETAINER, INSULATION DIAL	242
- - 2 -	2168400-7	SHCS, LOW HEAD, RoHS, M5 X 10	240
- - - 1	2063440-1	AIR FEED MODULE	238
- - 1 -	2119740-2	TAG, IDENTIFICATION	213
- 4 4 4	2079383-9	SCR, BHSC, RoHS (M6 X 20)	186
- - REF -	1901697-1	FEED FINGER ASSEMBLY, EF	183
- 1 1 1	1-1752354-7	STANDOFF, HOLD-DOWN	180
- 1 1 1	6-993111-6	PIN, SLOTTED SPRING 3.0 X 14.0	177
- 1 1 1	8-22280-7	SPRING, COMPRESSION	176
- 1 1 1	1752353-2	GUIDE PIN, HOLDDOWN	175
- 1 1 1	1901680-2	GUIDE PIN, HOLDDOWN	174
- - - 2	21045-3	RING, RETAIN, EXTERN, 3/16 CRESCENT	172
- 1 1 1	994969-1	MAGNET, RARE EARTH HIGH ENERGY	166
- REFREFREF	994970-2	COUNTER, MAGNETIC	164
- - - 1	240638-1	SPRING, FEED FINGER	163
- 1 1 1	8-21084-1	O-RING, .801 ID, .070 DIA. MAT.	153
- - - 1	2119641-2	FEED CAM, AIR FEED	152
- 1 1 1	2119798-2	DETENT PIN	145
- 1 1 1	2079383-8	SCR, BHSC, RoHS (M4 X 16)	144
- 1 1 1	2119655-6	APPLICATOR BASIC ASSEMBLY, EF	141
- 1 1 1	2119651-1	RAM, ASIAN STYLE, END FEED	140
- 1 1 1	2119092-2	BOLT, ADJUSTMENT	139
- - - 1	3-23627-7	PIN, RETAIN, GRVD, 3/16 X .854	137
- - REF -	SEE NOTE 4	MEMORY CHIP, PROGRAMMED	135
- - 1 -	1633743-1	SERVO FEED LATCH ASM	133
- 1 1 1	455888-4	SPACER, CRIMPER	82
- 1 1 1	2119791-5	DEPRESSOR, WIRE	73
- 1 1 1	2119956-2	DOCUMENTATION PACKAGE	71
- 2 2 2	2-18032-2	SCR, SET, FLT POINT M3 X 10.0	70
- 1 1 1	2119943-1	WASHER, SPACER	69
- 1 - 1	2119740-1	TAG, IDENTIFICATION	67
- 2 2 2	2168078-1	SCREW, DRIVE, RH, RoHS, 2 x .188	66
- 1 1 1	1901681-1	HOLDDOWN, TERMINAL	65
- 2 2 2	2168400-5	SHCS, LOW HEAD, RoHS, M4 X 20	64
- 1 1 1	2119793-1	LIMITER, ADJUSTMENT BOLT	63
- 3 3 3	992763-5	SCR, SET, SOC, CONE POINT, M3 X 4.0	62
- 3 3 3	2168400-4	SHCS, LOW HEAD, RoHS, M4 X 8	57
- 2 2 2	2168083-3	SCR, SKT HD CAP, RoHS, M4 X 12.0	56
- 2 2 2	5018030-2	NUT, HEX, REG, RoHS, M4	55
- 2 2 2	5018030-1	NUT, HEX, REG, RoHS, M3	54
- 2 2 2	986965-8	NUT, LOCK, HEX, TORQUE (M4)	53
- 1 1 1	1-5018030-0	NUT, HEX, REG, RoHS, M3.5	52
- - - 1	2119792-2	PAWL, EF, AIR	51
- - - 1	18023-9	SCR, SKT HD CAP M4 X 6.0	49
- 1 1 1	2079383-7	SCR, BHSC, RoHS (M8 X 25)	41
- 1 1 1	2119645-1	DISC, NUMBERED FA WIRE ADJUSTMENT	40
- 1 1 1	2119957-1	APPLICATOR SHIM PACK	39
- 1 1 1	2119644-3	RAM WASHER, PRECISION	38
- 7 7 7	1-18028-2	WASHER, FLAT, REG M4	33
- 2 2 2	2168083-9	SCR, SKT HD CAP, RoHS, M4 X 20	31
- 2 2 2	1-2168083-0	SCR, SKT HD CAP, RoHS, M4 X 10	29
- 1 1 1	240639-1	STRIPPER (MACHINING)	27
- 2 2 2	1320906-1	STUD, THREADED	25
- 1 1 1	1-1752371-2	PLATE, STRIP GUIDE	24
- 1 1 1	240825-1	PLATE, STRIP HOLD DOWN	23
- 2 2 2	2-22281-3	SPRING, COMPRESSION	22
- 1 1 1	1752373-4	DRAG	20
- 2 2 2	1901259-5	GUIDE, LOWER STRIP	18
- 1 1 1	1752360-1	SPACER, HOLD-DOWN	13
- 1 1 1	240644-5	PLATE, REAR SHEAR	11
- - - -	-	-	10
- 1 1 1	2-690496-6	PLATE, FRONT SHEAR	9
1 1 1 1	1-1803059-8	ANVIL, COMBINATION, END FEED	8
- 1 1 1	1-2217206-0	BLADE, SLUG	7
- - - -	-	-	6
- 1 1 1	1-240641-5	SPACER	5
- 1 1 1	238009-8	BLOCK, FL CRIMPER SPACER	4
1 1 1 1	3-1633961-0	CRIMPER, INSULATION F PREMIUM	3
- 1 1 1	455888-1	SPACER, CRIMPER	2
1 1 1 1	1-456406-5	CRIMPER, WIRE PREMIUM	1

DIMENSIONS:		TOLERANCES UNLESS OTHERWISE SPECIFIED:		DWG		CHK		NAME	
mm	0 PLC ±.5	1 PLC ±0.5	2 PLC ±0.13	3 PLC ±0.013	4 PLC ±0.001	ANGLES ±.001	FINISH	APVD	U. GUO
MATERIAL		WEIGHT		SCALE	1:1	SHEET	3	OF	4
Customer Accessible Production Drawing				REV	A				

LOC		DIST		REVISIONS			
A	66	P	LTM	DESCRIPTION	DATE	DWN	APVD
		-		SEE SHEET 1			

HOLDDOWN SET-UP

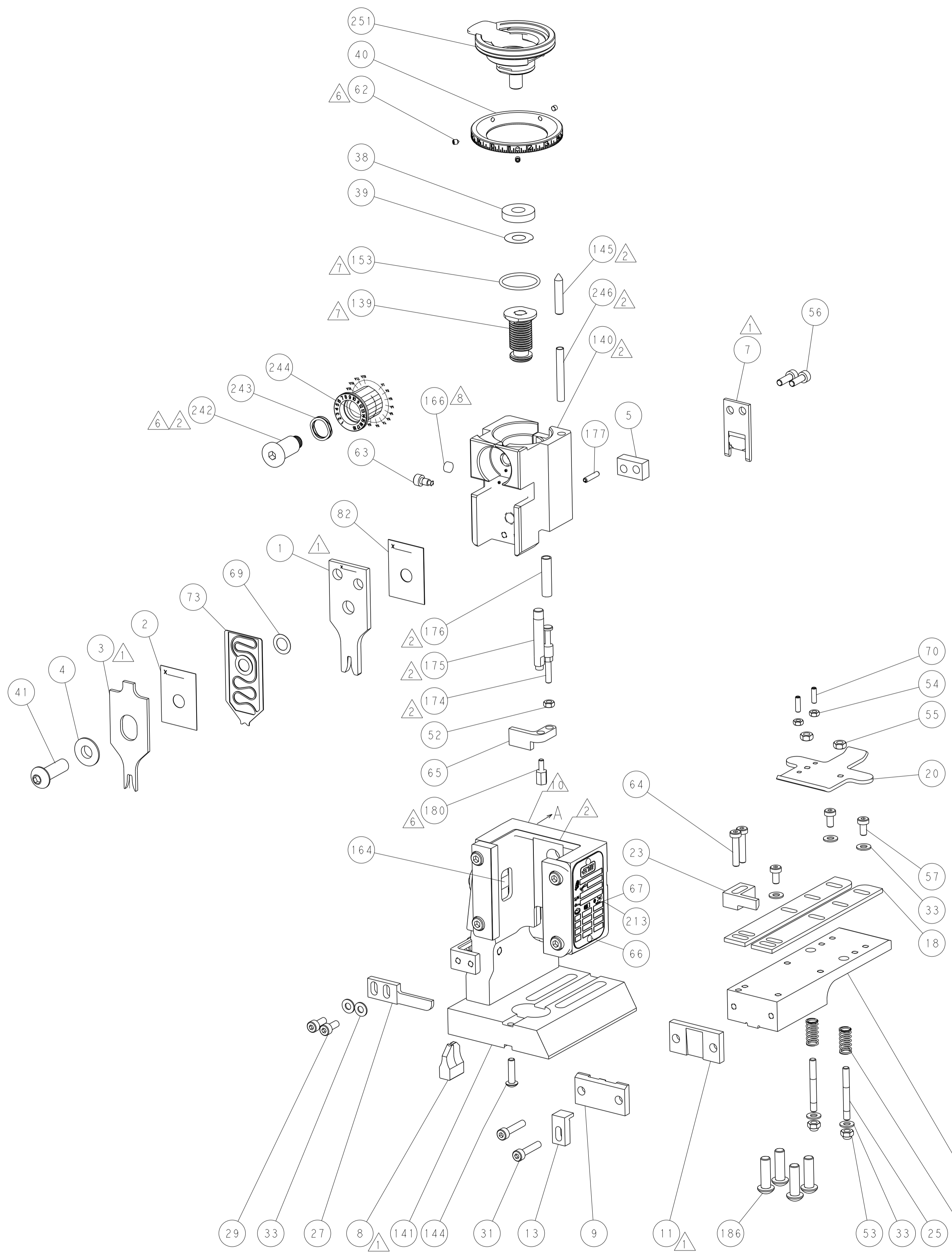
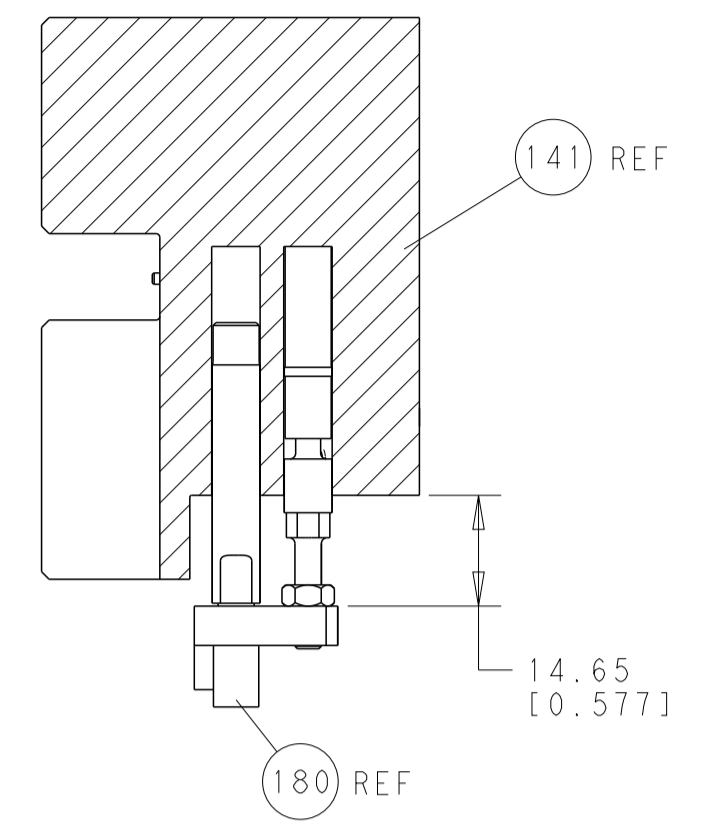

FEED TYPE PNEUMATIC

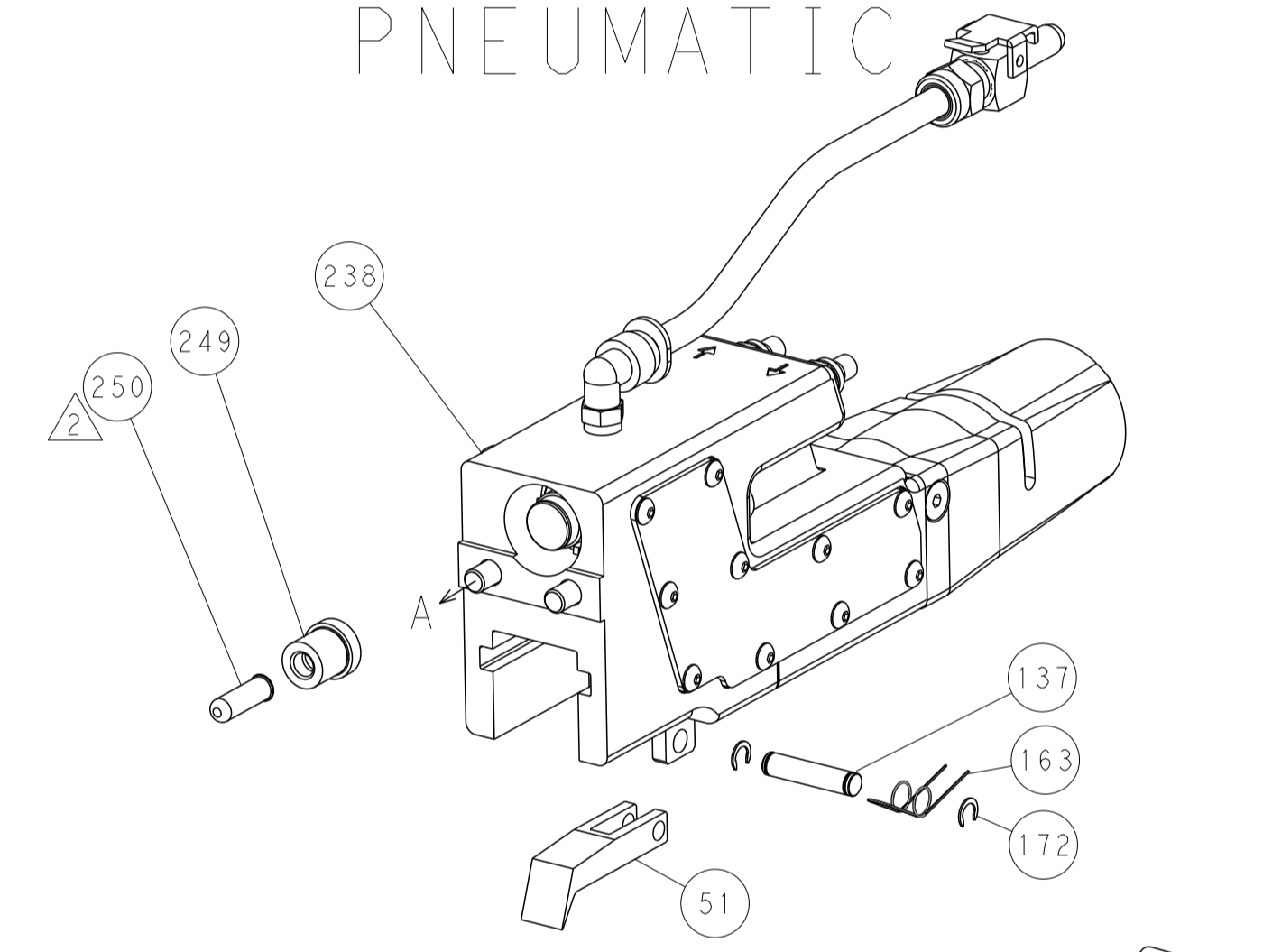

SERVO LATCH PLATE

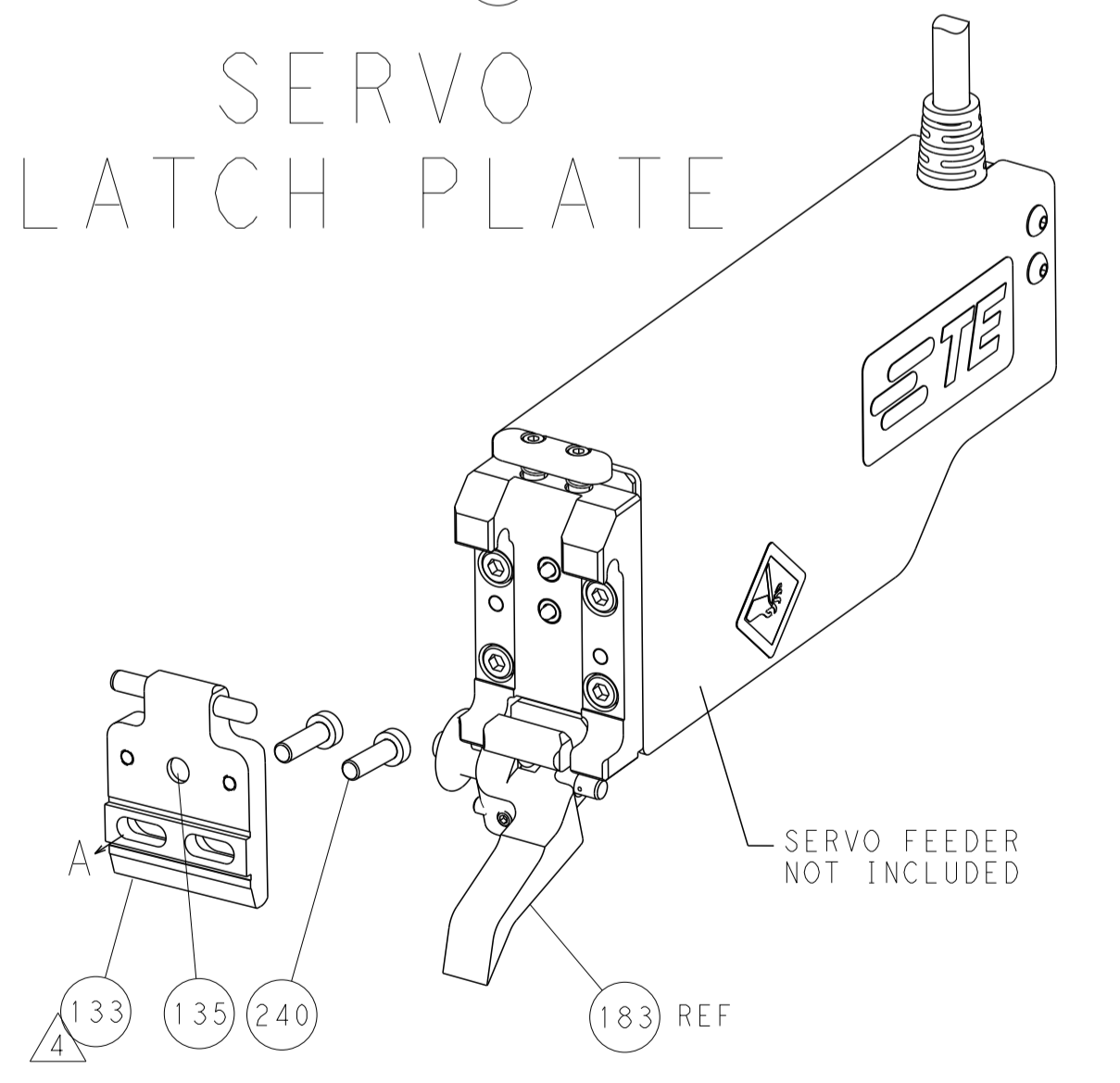

CAM POSITIONS

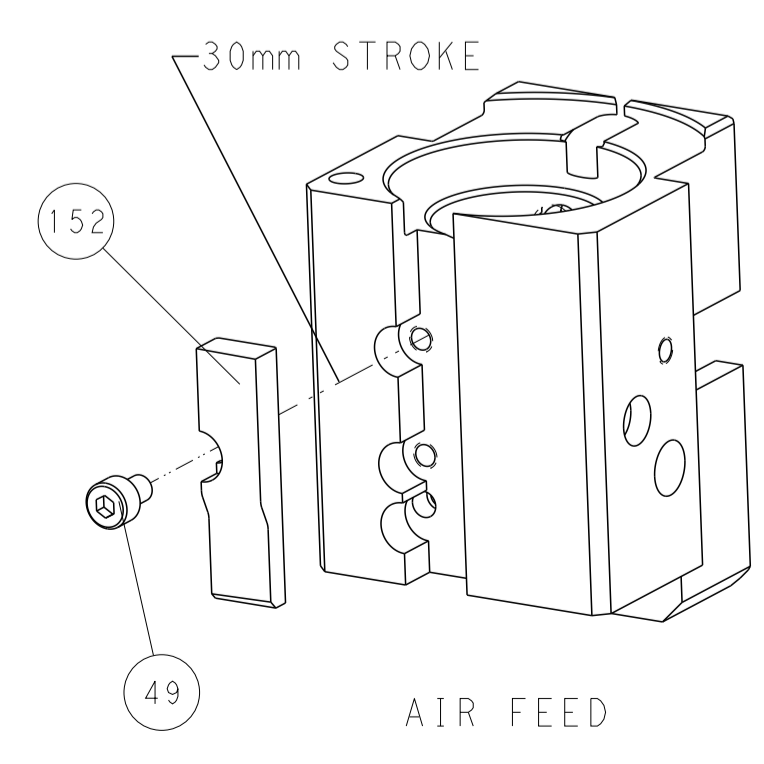

AIR FEED

PACIFIC VERSION
 Shown on sheets 3 of 4 & 4 of 4
 (Atlantic version shown on sheets 1 of 4 & 2 of 4)

DIMENSIONS:		TOLERANCES UNLESS OTHERWISE SPECIFIED:		DWN R. HUANG 05JAN2015		STE TE Connectivity Harrisburg, PA 17105-3608	
mm	0 PLC ±0.5	1 PLC ±0.5	2 PLC ±0.13	3 PLC ±0.013	4 PLC ±0.001	APVD L. ZHANG 05JAN2015	NAME Ocean End Feed Applicator
MATERIAL:		FINISH:		WEIGHT:		SIZE CAGE CODE DRAWING NO A1 00779 C=2150516	
Customer Accessible Production Drawing				SCALE 1:1		SHEET 4 OF 4 REV A	