

Reference	∅ ISO	L (mm)	H1 (mm)	H2 (mm)	Clamping range min/max	Clamping range on fail ∅ min	Torque (Nm) on the hood	Torque (Nm) on the body	Thread A
UTOS10JCS	M16	58.5	14	17	04/6.5	04	5	6	9/16-24 UNEF Class 2A
UTOS10JCSL	M16	59.5	17	17	05/8.5	4.5	5	6	9/16-24 UNEF Class 2A
UTOS12JCS	M20	61.5	20	22	07/10.5	06	8	10	11/16-24 UNEF Class 2A
UTOS12JCSL	M20	61.5	22	22	08/12.5	08	8	10	11/16-24 UNEF Class 2A
UTOS14JCS	M20	66.5	20	22	07/10.5	06	8	10	13/16-20 UNEF Class 2A
UTOS14JCSL	M20	66.5	22	22	08/12.5	08	8	10	13/16-20 UNEF Class 2A
UTOS16JCS	M25	72.5	24	26	10/14.5	10	12	14	15/16-20 UNEF Class 2A
UTOS16JCSL	M25	82.5	30	30	13.5/18	13.5	12	14	15/16-20 UNEF Class 2A
UTOS18JCS	M25	75.5	24	26	10/14.5	10	12	14	1" 1/16-18 UNEF Class 2A
UTOS18JCSL	M25	85.5	30	30	13.5/18	13.5	12	14	1" 1/16-18 UNEF Class 2A
UTOS20JCS	M32	84	30	33	13.5/18	13.5	20	24	1" 3/16-18 UNEF Class 2A
UTOS20JCSL	M32	93	40	40	17/24	17	20	24	1" 3/16-18 UNEF Class 2A
UTOS22JCS	M32	90.0	30	33	13.5/18	13.5	20	24	1" 5/16-18 UNEF Class 2A
UTOS22JCSL	M32	99	40	40	17/24	17	20	24	1" 5/16-18 UNEF Class 2A
UTOS24JCS	M32	95.5	30	33	13.5/18	13.5	20	24	1" 7/16-18 UNEF Class 2A
UTOS24JCSL	M32	104.5	40	40	17/24	17	20	24	1" 7/16-18 UNEF Class 2A

Shielded version

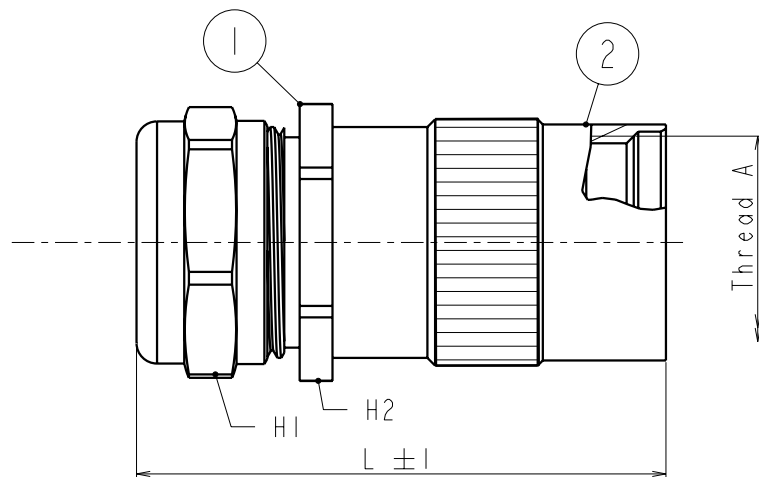

MATERIAL :

Cable clamp: Brass nickel plated
Tube: Brass nickel plated

PERFORMANCE CHARACTERISTICS :

Operating temperature: -40°C up to 105°C
Corrosion salt spray: 96 hours

A	07/06/04	--	Creation of the drawing		--
ISS	DATE	Latest modification - by:	--	MOD N°	
Designed by:		C. PROVOST	Date: 07/06/04	Type of drawing:	ASSEMBLAGE
Checked by:		SEE DISTRIBUTION LIST	Date:	SEE DISTRIBUTION LIST	
TITLE		Connector UTO et UTOW Kit cable clamp with tube			
Scale	General angular	MATERIAL : --			
3/1	Tolerances: ± --				
Geometrical Tolerances	General linear	General machining	Geometrical Tolerances	PROJECT	
	Tolerances: ± --	surface texture	See NF E 04-552	MSK1	
		SOURIAU Route Nationale 23 72470 CHAMPAGNE Tel. (33)02.43.54.35.00		This document is the property of SOURIAU It must not be reproduced or communicated without permission	
FORMAT	SOURIAU DRG N°			SHEET	
A2	UTOSXXJCS-C02			1 / 1	