

S12-275VPD-5VCB2

Digital Ferrous Metal Detection Sensor

- Ferrous Metal Hall Proximity Sensor
- .375" detection gap
- 5V input voltage
- Stainless 12x1mm x 35mm housing
- Integral 4 pin male 12mm micro connector



CUSTOMER FOCUSED ENGINEERING + MODULAR DESIGN

Part Description: **S12-275VPD-5VCB2**

Housing	Sensor Type & Function	Electrical Option	Connection Type
S = Stainless Steel, Thread Pitch M12x1, 35mm Long	Digital Ferrous Metal Proximity Sensor	5V Operation	CB2 = Integral 4 Pin Male 12mm Micro Connector

Modify, update, or enhance any sensor with our modular features and functionality.

HOUSING - Aluminum, stainless steel, plastic, threaded, flange mount, customer specific

ELECTRICAL - Every sensor function available in various electrical options (NPN, PNP, TTL, etc.)

CONNECTION - Deutsch, Amphenol, many other brands, free end wires, pigtails, any length

Need a Custom Sensor Solution?... Send us your application specific requirements at sensorso.com

'Digital Output switches on when Ferrous Metal is present'

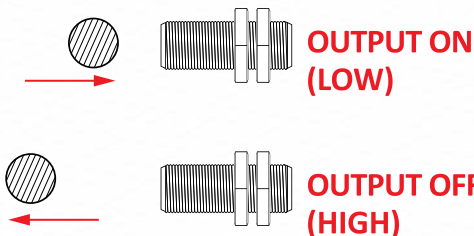

Type - DP

DESCRIPTION

- Digital output turns on when ferrous metal is detected
- Programmed to detect a large steel target at 0.375"
- Target detection gap is dependent on shape/size/ferrous content.
- Custom programming available for precision repeatable detection of targets, contact Sensor Solutions.
- Provided lock nuts used to set air gap from target.

FEATURES

- True Zero Speed
- Large Detection Gap
- Internal Hysteresis
- Detects Through Aluminum

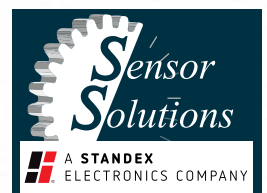

S12-275VPD-5VCB2

Digital Ferrous Metal Detection Sensor

Note: Check our website or contact us for details on all our ferrous metal detection options.

Electrical Specifications	Conditions	Min	Max	Unit
Temperature Range*	Operating	-40	+110*	Deg C
Supply Voltage, Vcc	Over temperature	+4.5	+5.5	Volts DC
Supply Current	Into Vcc	(typ 7)	+10	mA
Output Current	Continuous	-1	+1	mA
Load Capacitance	Cable and Load	n/a	+1.0	µF
Frequency Range **	Std Programmable	0	500	Hz
Frequency Range **	Max Programmable	0	2000	Hz
Digital Voltage Low Vol	I sink < 1.0 mA	0	(typ 0.2)	Volts
Digital Voltage High Voh	I source < 1.0 mA	(typ 4.8)	Vcc	Volts
Output Rise Time 10-90%	Ro=10k, C<100 pF	-	5	µS
Output Fall Time 90-10%	Ro=10k, C<100 pF	-	5	µS

* T max = 150°C is available, contact factory.

** Frequency, Detection and Hysteresis are Factory Programmable.

Rev D

Absolute Max Limits	Min	Max	Unit
Supply Voltage, Vcc	-24	+30	Volts DC
Voltage at Output	-5	+8.5	Volts
Reverse Supply Current	-	5.0	mA
Peak Output Current	-10	+10	mA
Vout Short Circuit Duration	-	10	Minutes

Environmental Specifications

Corrosion Resistance	500 hours salt spray ASTM B-117
Installation Torque	23 Foot-Pounds Maximum
Enclosure	Nema 1,3,4,6,13 & IEC IP67
Vibration	10 G's 2 to 2000 Hz Sinusodal
Mechanical Shock	100 G's, 11 mS Half-Sine

S12 Housing, 303 Stainless Steel, M12X1, 35mm Long

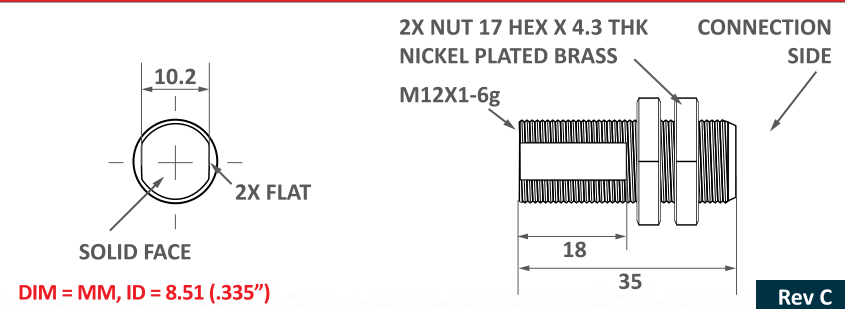

Rev C

Functional Characteristics @25°C

	Min	Typ	Max
<i>Sensor Programming + target ferrous content, shape, & size will affect gaps</i>			
Output State, No Target Present: Low (~0V)			
Detect Large Steel Target T=25C**	0.350"	0.375"	0.400"
Hysteresis, Large Steel Target T=25C**	.020"	.050"	.080"
Detect 0.5" ø Steel Target	-	.360"	-
Detect 0.1" ø Steel Target	-	.215"	-

** Frequency, Detection and Hysteresis are Factory Programmable and can be decreased upon request.

CB2, Integral 4 Pin Male 12mm Micro Connector

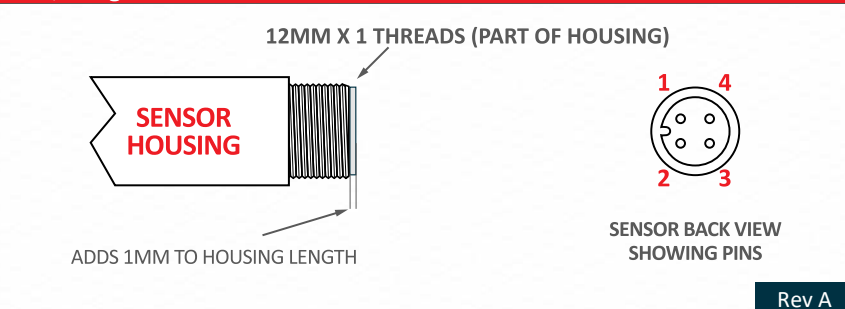

Rev A

Connections Chart

Pin 1	Vcc	Pin 3	Ground
Pin 2	Program/LEAVE OPEN	Pin 4	Digital Vout
CB2-275VPD			



Caution: A short from the Pin 2 Program wire to either Pin 1 Vcc or Pin 3 Ground wire will cause component failure.

OTHER MATING CONNECTORS AND CABLES AVAILABLE

S12-275VPD-5VCB2

Digital Ferrous Metal Detection Sensor

Sensor Function

ANY FERROUS TARGET

Air Gap

NO ORIENTATION REQUIRED

S12-275VPD

Date Code 'YYM' YY = YEAR, M = MONTH

A JAN	D APR	H JUL	L OCT
B FEB	E MAY	J AUG	M NOV
C MAR	G JUN	K SEP	N DEC

Marking

DATE CODE, THIS SURFACE

275VPD-5V_yy 06A

CHARACTERISTIC-OPTION_PROGRAMMING MARKED ON THIS SURFACE yy = PROGRAM #

5V, 5V Operation

SENSOR

4.5 TO 5.5V

Vout 0-5V (Each Channel)

LOAD

GND

Handling Instructions

DO NOT CONTACT FACE TO FACE

CONTACT WITH OTHER MAGNETS MAY REDUCE THE MAXIMUM OPERATING GAP

Please note: All technical specifications on this series datasheet refer to the standard product range. Modifications in the sense of technical progress are reserved. For general information only. For more specific information, please consult the product datasheet, available upon request.

This series datasheet could contain technical inaccuracies or typographical errors. Changes are periodically made to the information herein. These change will be incorporated in future revisions.

For deviating values, most current specifications and products please contact your nearest sales office.