



A Tallysman Accutenna® TW3142 High Gain / High Rejection Antenna

The TW3142 is a high-gain GPS antenna specifically designed for applications in environments where high levels of near-out-of-band interfering signals can be expected. This antenna features a 40dB LNA gain to handle long cable runs.

The TW3142 covers the GPS L1 and SBAS (WAAS, EGNOS & MSAS) frequency band and employs Tallysman's unique *Accutenna™* technology to provide excellent cross polarization rejection and greatly enhanced multipath rejection.

The TW3142 features a three (3) stage dual filtered LNA plus an additional SAW pre-filter to provide exceptional rejection of close out-of-band signals and additional protection against saturation by high level sub-harmonic and L-Band signals..

The TW3142 housing has a permanent mount, IP67 compliant metal base, and an extended temperature range plastic radome, and is specifically designed to withstand the most challenging environmental conditions.

Two options for pole mounting are available an L-bracket (P/N#23-0040-0) or a pipe mount (P/N#23-0065-0).

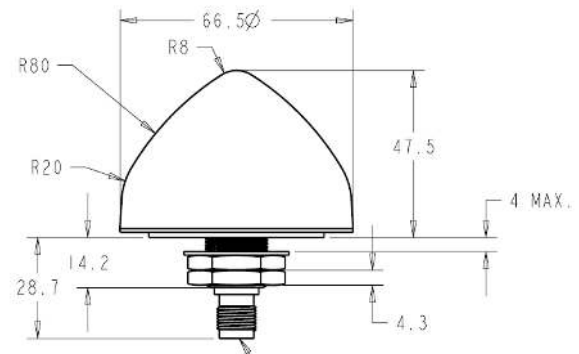

Applications

- Timing systems
- Long cable runs

Features

- Dual Feed Patch Antenna
- Low Loss SAW Pre-Filter
- Great axial ratio: 1 dB typ.
- Low noise LNA: 3.5dB typ
- Dual High rejection SAW filter
- High gain LNA: 40 dB typ.
- Low current: 19 mA typ.
- Wide voltage input range: 2.7 to 16 VDC
- IP67 weather proof housing

Benefits

- Great out of band rejection
- Excellent multipath rejection
- Excellent circular polarisation
- Excellent signal to noise ratio
- Increased system accuracy
- Ideal for harsh environments
- RoHS and REACH compliant

