

16+Gbps 0.5mm pitch Stacking Connectors

XG1 Series

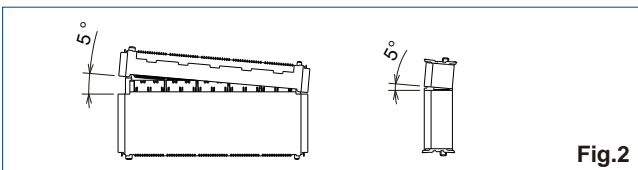
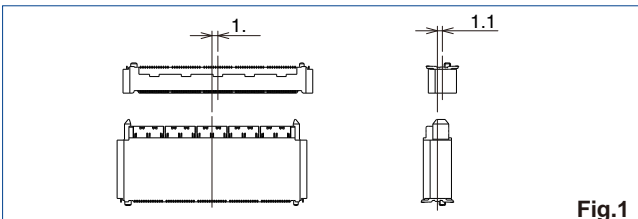
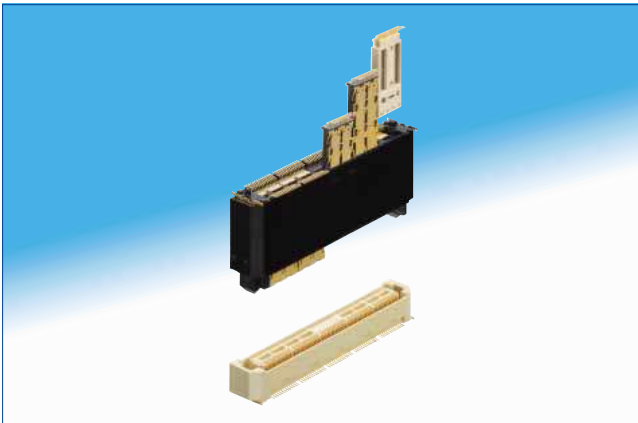

Mechanical Features

- 0.5mm Pitch / Double-Row SMT
- Stacking Height : 20~23mm (2 pieces)
30~44mm (3 pieces)
- Number of Contacts : 52 / 78 / 104 / 130 /
156 / 208 / 260pos
- SMT Coplanarity
The coplanarity of the SMT solder area lead is maintained at the high accuracy of less than 0.1mm.
- "Transmission Blade" Variations
Differential 100 ohms and Differential 85 ohms,
Power blade
Multiple blade combinations are available.
- Large Self Alignment (Fig.1)
Alignment on plug provides easy insertion operation.
Using optional guide self alignment becomes ± 4 mm.
- Anti-Damage Structure (Fig.2)
Angled insertion is acceptable up to 5°.
- Soldering Reliability
XG1 utilizes the same contact design for both signal and ground, which conducts the heat equally.
- Mating Length : 1.2mm

Signal Integrity Features

- Insertion-loss-to-Crosstalk-Ratio (ICR)
The insertion-loss-to-crosstalk ratio (ICR) with seven differential FEXT aggressors meets the extrapolated IEEE802.3ap specification to 16+ Gbps.
- Differential Impedance
The differential impedance is 85 ohms config and 100 ohms config are available.

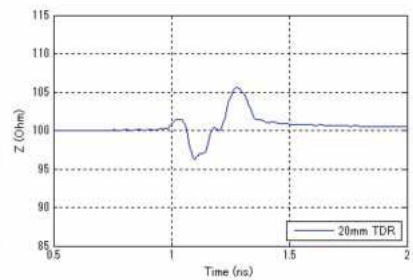
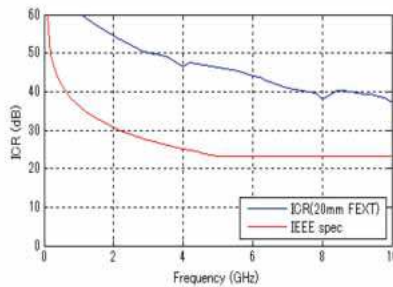

Transmission Blade Variations

Power Blade
Current Capacity :
7 Amps / 20mm blade

Ex.

3.3V@3.5A	2.4V@3A
2.4V@3A (Return)	3.3V@3.5A (Return)

Differential Blade
Impedance : 85 ohms

Differential Blade
Impedance : 100 ohms

- GND plate
- Dedicated Ground
- Grounded Pins
- Differential pair

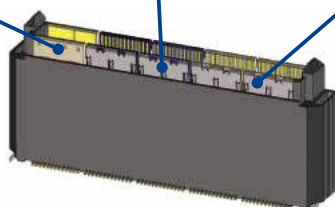

Production Specifications

Ratings	Current rating	0.3A	Operating temperature range	-55°C to +85°C (Note 1)	Storage temperature range	-10°C to +60°C (Note 2)
	Current voltage	50V AC	Operating humidity range	Relative humidity 90% (No condensation)	Storage humidity range	40% to 70% (Note 2)

Item	Specification	Conditions
1. Insulation resistance	100M ohms min.	100V DC
2. Withstanding voltage	No flashover or insulation breakdown.	150V AC / 1 minute
3. Contact resistance	130m ohms max. (* Including conductor resistance.)	100 mA
4. Vibration	No electrical discontinuity of 1μs or more. No damage, cracks, or parts dislocation.	Frequency : 10 to 55Hz, single amplitude of 0.75mm, 10 cycle in each of the 3 directions.
5. Shock	No electrical discontinuity of 1μs. min. No damage, cracks, or parts dislocation.	Acceleration of 490m/s ² , 11ms duration, sine half-wave waveform, 3 cycles in each of the 3 axis
6. Humidity	Contact resistance : 150m ohms max.	96 hours at 40°C±2°C and humidity of 90% to 95%
7. Temperature cycle	Insulation resistance : 100M ohms min. No damage, cracks, or parts dislocation.	Temperature : -55°C → +15°C to +35°C → +85°C → +15°C to +35°C Duration : 30 → 5 max. → 30 → 5 max. (Minutes) 5 cycles
8. Durability (insertion / withdrawal)	Contact resistance : 150m ohms max. Insulation resistance : 100Mohms min. No damage, cracks, or parts dislocation.	20 cycles
9. Resistance to soldering heat	No deformation of components affecting performance.	Reflow : At the recommended temperature profile (Peak temperature : 260°C max.) Detailed solder profile can be requested.

Note1 : Includes temperature rise caused by current flow.

Note2 : The term "storage" refers to products stored for long period of time prior to mounting and use. Operating Temperature Range and Humidity range covers non-conducting condition of installed connectors in storage, shipment or during transportation.

Materials / Finish

Receptacle

Part	Material	Finish	Remarks
Insulator	LCP	Color : Beige	UL94V-0
Contacts	Copper alloy	Contact area : Gold plated Lead area : Gold plated	—
Retention peg	Copper alloy	Lead area : Gold plated	—

Plug

Part	Material	Finish	Remarks
Insulator	PA / LCP LCP	Color : Black Color : Beige	UL94V-0
Contacts	Copper alloy	Contact area : Gold plated Lead area : Gold plated	—
Ground contacts	Copper alloy	Contact area : Gold plated	—
Retention peg	Copper alloy	Lead area : Gold plated	—

Interposer

Part	Material	Finish	Remarks
Insulator	PA LCP	Color : Black / Beige Color : Beige	UL94V-0
Contacts	Copper alloy	Contact area : Gold plated	—
Ground contacts	Copper alloy	Contact area : Gold plated	—

Product Number Structure

Refer to the chart below when determining the product specifications from the product number.

Please select from the product numbers listed in this catalog when placing orders.

Receptacle

XG1 - 130 S - SV - *H ()**

① ② ③ ⑦ ⑧ ⑨

Plug

XG1 - 130 P / ** 30 - 20H - SV ()**

① ② ③ ④ ⑤ ⑥ ⑦ ⑨

Interposer

XG1 - 130 P / ** 30 - 30H ()**

① ② ③ ④ ⑤ ⑥ ⑨

① Series name	: XG1
② Number of contacts (Including Ground contacts)	: 52 to 260
③ Connector type	S : Receptacle P : Plug or Interposer
④ Blade assignment	Blank : All 100 ohms blade Q** : Including 85 ohms blade D** : Including power blade
⑤ Number of Ground contact	: 12 to 60
⑥ Stacking Height (mm)	: 20 to 38 ※height with XG1-**-S-V
⑦ Contact type	SV : SMT vertical mounting type Blank : Interposer
⑧ Receptacle height	: Blank, 2, 3
⑨ Peculiar Specification	Blank : Contact Area : Gold (0.2μm) + Ni (1.5μm) Receptacle : Tape and Reel Packaging Plug : Hard Tray Packaging Interposer : Soft Tray Packaging *0.76μm gold plating type is also available.

Function Chart

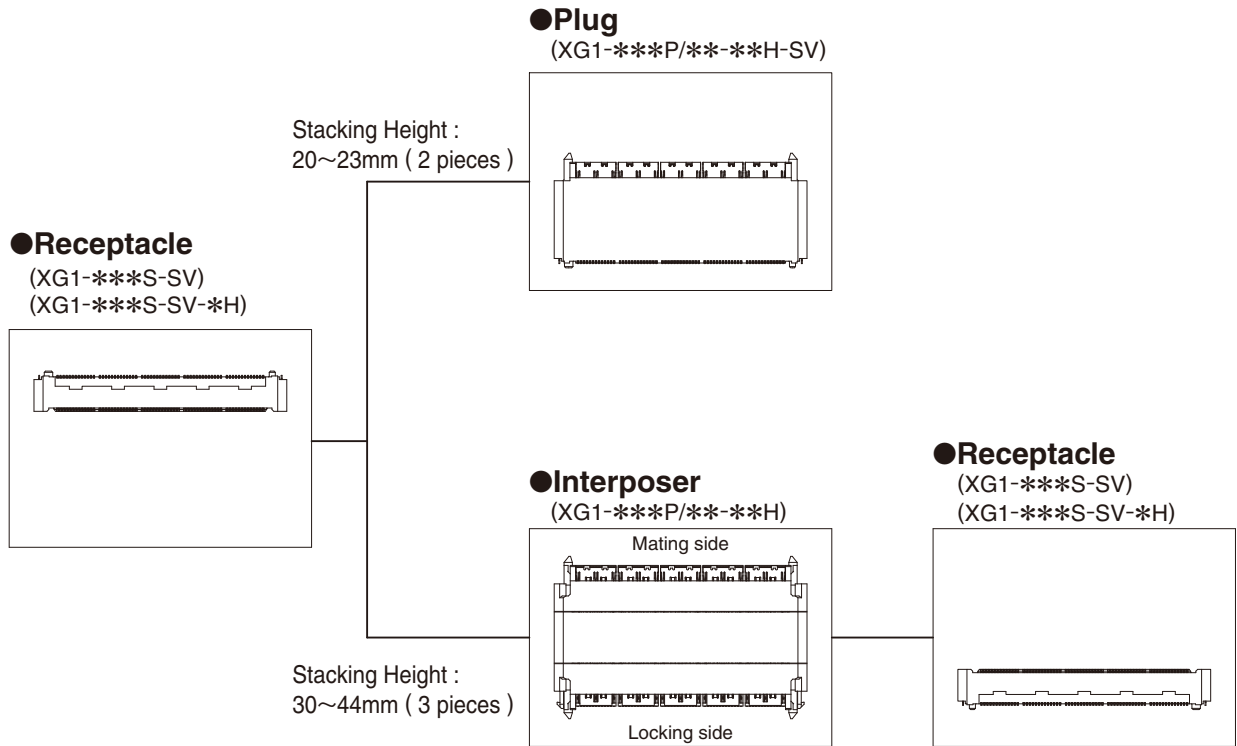

Stacking Height Variation

Part No.	Stacking height (mm)														
	20	22	23	30	32	33	34	35	36	38	40	41	42	43	44
Receptacle	XG1-***S-SV	○			◎	○	○				◎	○	○		
	XG1-***S-SV-2H		○			○		◎	○		○		◎	○	
	XG1-***S-SV-3H			○			○	○	◎			○		○	◎
Plug	XG1-***P/**-20H-SV	○	○	○											
Interposer	XG1-***P/**-30H				○	○	○	○	○						
	XG1-***P/**-38H									○	○	○	○	○	○

◎ : Two pieces required

■ Signal Integrity

● Pin assignment

To match 100 ohms differential impedance and to reduce crosstalk, a GSSG pin assignment is recommended for XG1. (G=ground and S=signal)

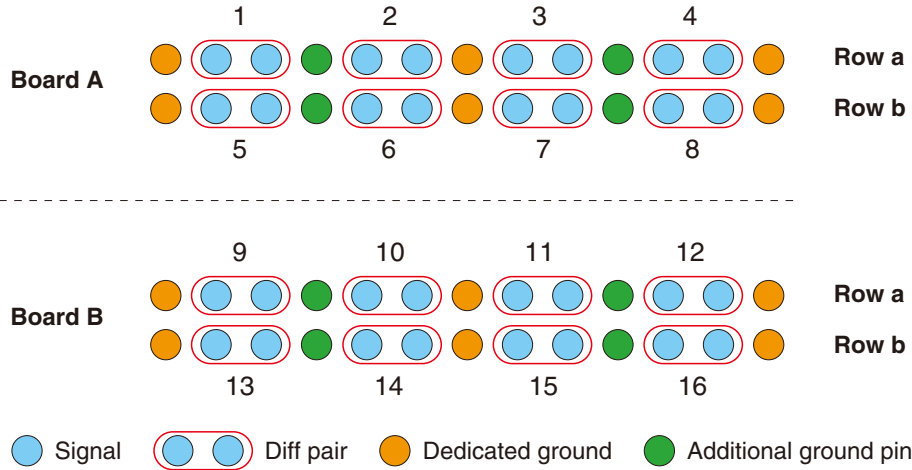

● Impedance

The differential impedance is 100 +/- 10ohm at 60ps rise time (20% to 80%).

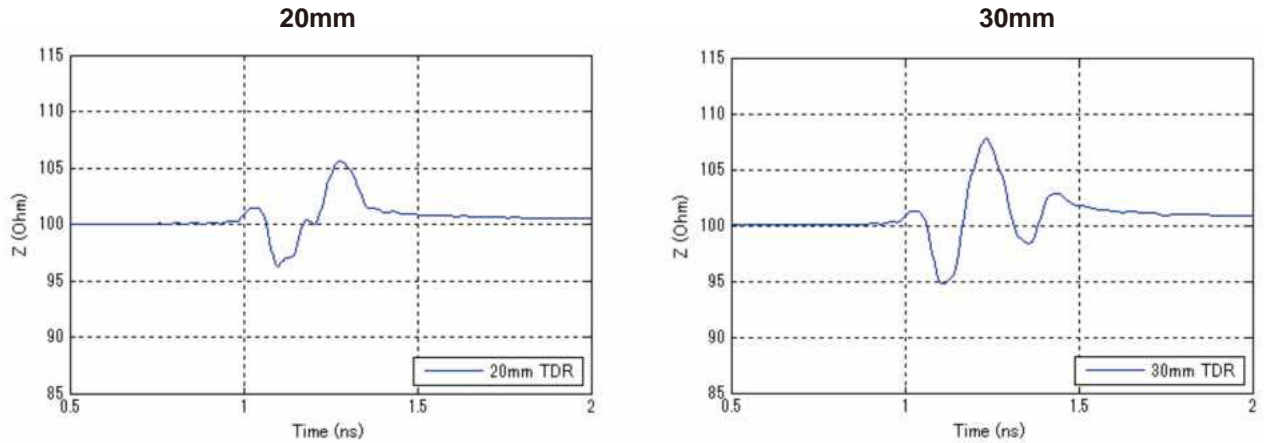

● Propagation delay

The propagation delay is 132 and 200 ps for XG1 of 20mm and 30mm height, respectively.

● Insertion Loss

20mm

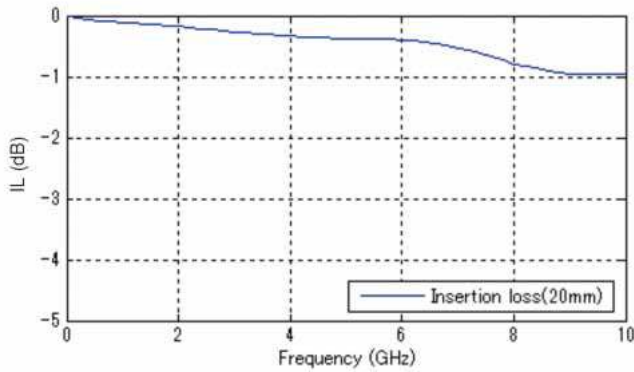

30mm

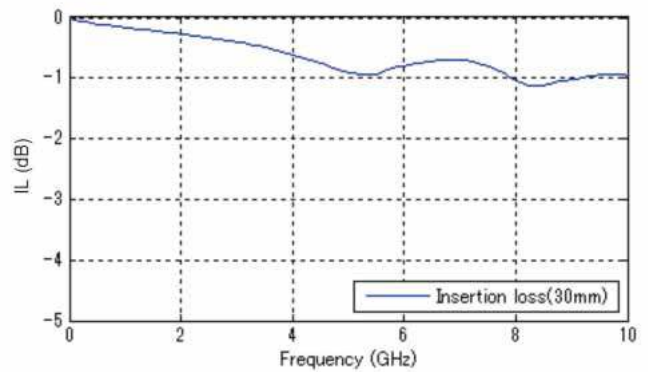

● Return loss

20mm

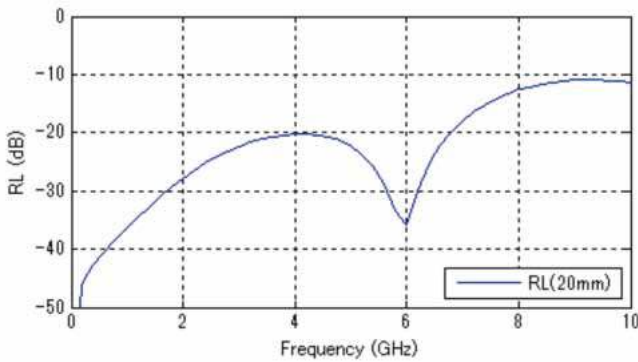

30mm

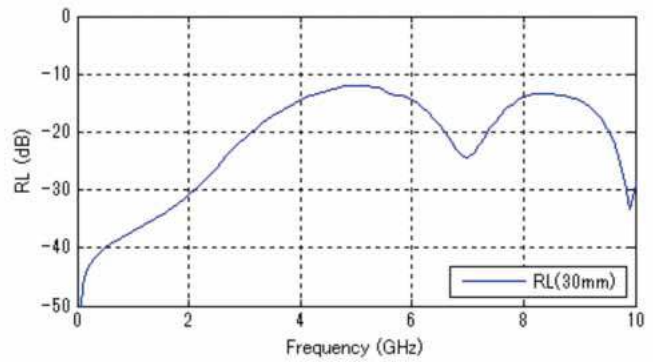

● Near-end crosstalk (NEXT)

The GSSG pin assignments resulted in low differential NEXT.

20mm

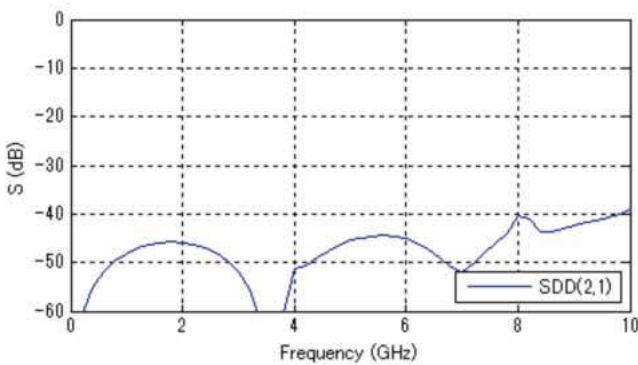

30mm

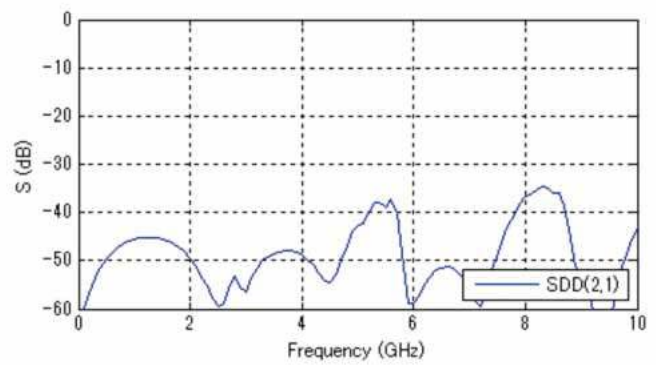

● Far-end crosstalk (FEXT)

The GSSG pin assignments resulted in low differential FEXT.

20mm

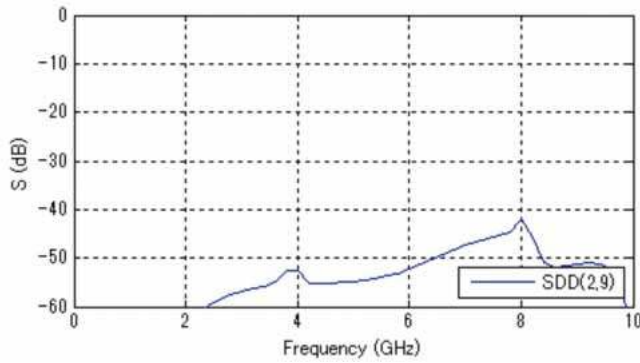

30mm

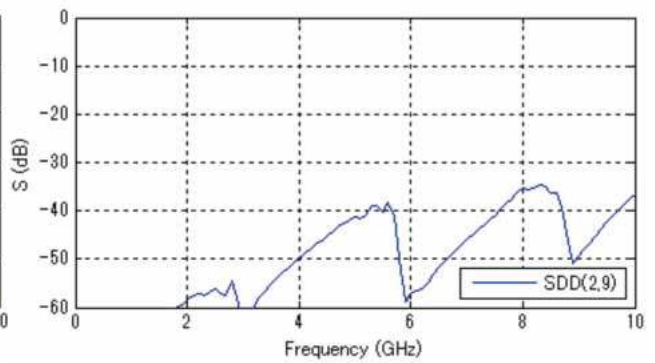

● Insertion-loss-to-crosstalk ratio (ICR)

The insertion-loss-to-crosstalk ratio (ICR) with seven differential FEXT aggressors meets the extrapolated IEEE802.3ap specification to 10+GHz.

20mm

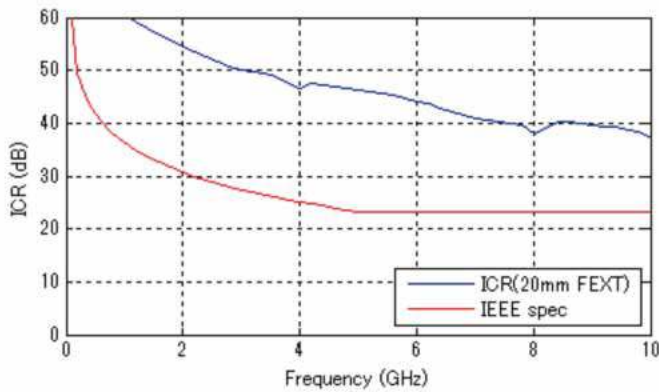

30mm

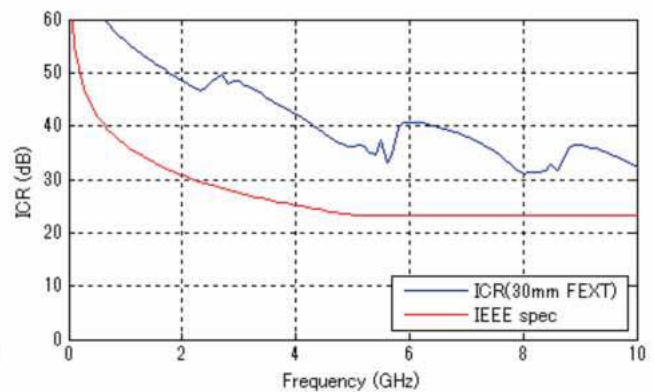

■ Receptacle

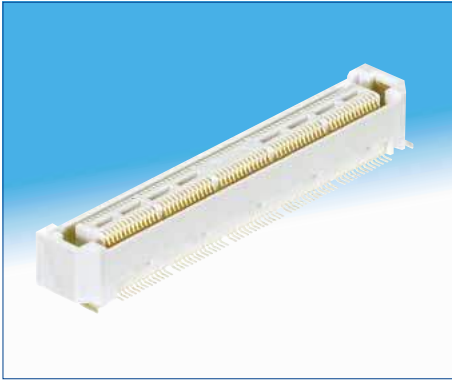

■ Number of Contact : 52 to 130

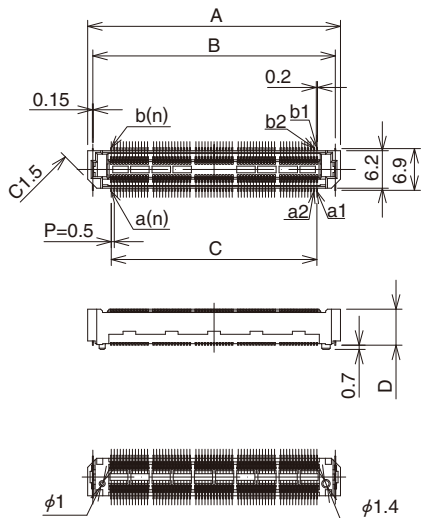

■ Number of Contact : 156 to 260

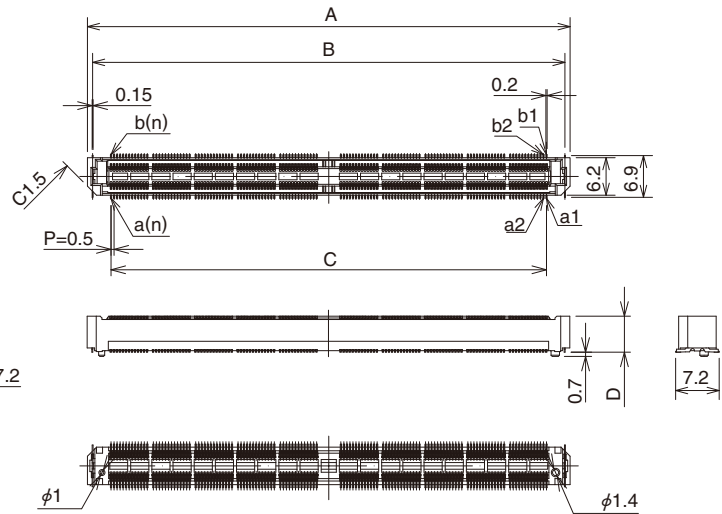

All dimensions in mm

Part No.	HRS No.	No. of Contacts	A	B	C	D	n
* XG1-52S-SV	TBD	52	20.8	19.09	13	5.95	26
* XG1-78S-SV	TBD	78	27.8	26.09	20	5.95	39
XG1-78S-SV-2H	624-0008-1	78	27.8	26.09	20	7.95	39
XG1-78S-SV-3H	624-0009-4	78	27.8	26.09	20	8.95	39
* XG1-104S-SV	TBD	104	34.8	33.09	27	5.95	52
XG1-130S-SV	624-0001-2	130	41.8	40.09	34	5.95	65
XG1-130S-SV-2H	624-0010-3	130	41.8	40.09	34	7.95	65
* XG1-130S-SV-3H	TBD	130	41.8	40.09	34	8.95	65
* XG1-156S-SV	TBD	156	51.8	50.09	44	5.95	78
* XG1-208S-SV	TBD	208	65.8	64.09	58	5.95	104
XG1-260S-SV	624-0002-5	260	79.8	78.09	72	5.95	130

* Please contact us.

■ Plug

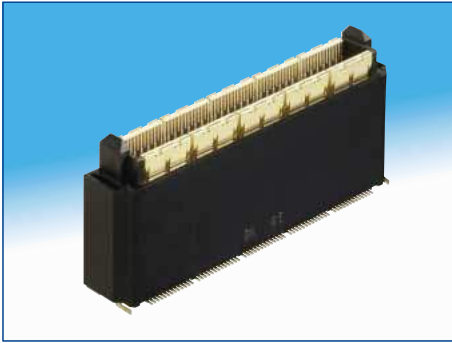

■ Number of Contact : 52 to 130

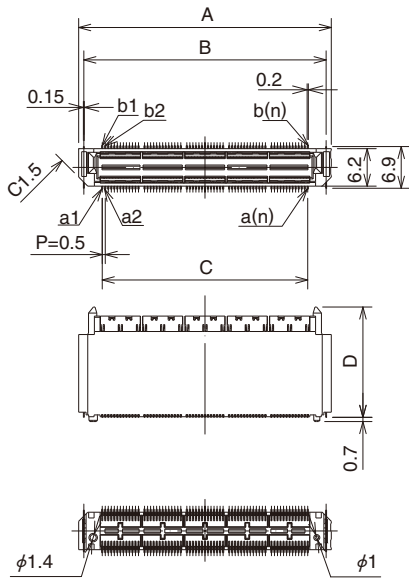

■ Number of Contact : 156 to 260

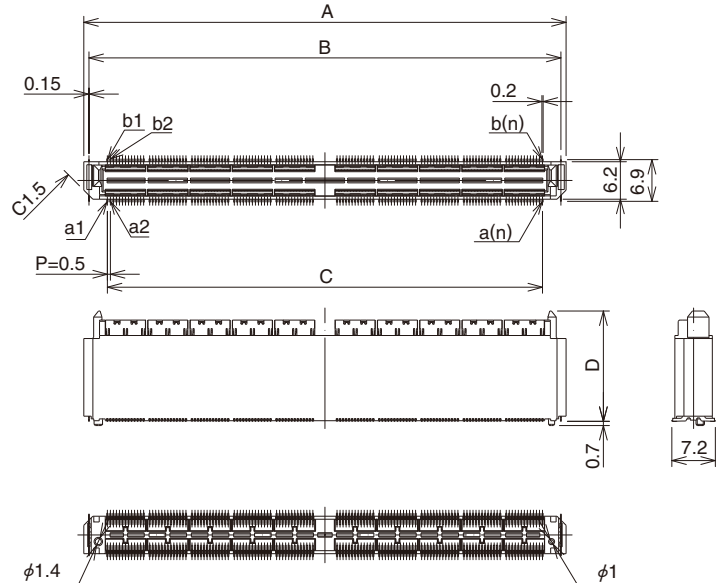

All dimensions in mm

Part No.	HRS No.	No. of Contacts(ground contacts)	A	B	C	D	n
* XG1-52P/12-20H-SV	TBD	52(12)	20.8	19.09	13	18.25	26
* XG1-78P/18-20H-SV	TBD	78(18)	27.8	26.09	20		39
* XG1-104P/24-20H-SV	TBD	104(24)	34.8	33.09	27		52
XG1-130P/30-20H-SV	624-0200-9	130(30)	41.8	40.09	34		65
* XG1-156P/36-20H-SV	TBD	156(36)	51.8	50.09	44		78
* XG1-208P/48-20H-SV	TBD	208(48)	65.8	64.09	58		104
XG1-260P/60-20H-SV	624-0201-1	260(60)	79.8	78.09	72	130	

* Please contact us.

Interposer



■ Number of Contact : 52 to 130

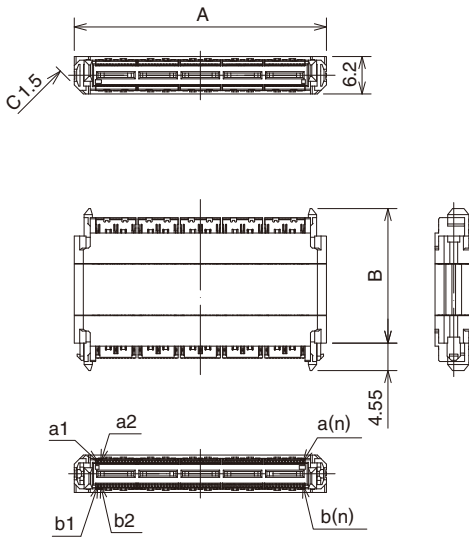

■ Number of Contact : 156 to 260

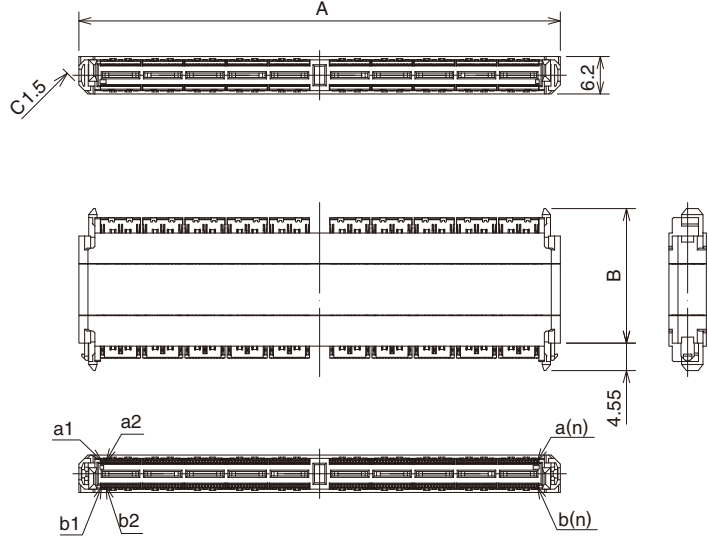

All dimensions in mm

Part No.	HRS No.	No. of Contacts(ground contacts)	A	B	n
* XG1-52P/12-30H	TBD	52(12)	20.8	22.3	26
* XG1-78P/18-30H	624-0606-3	78(18)	27.8		39
* XG1-104P/24-30H	TBD	104(24)	34.8		52
XG1-130P/30-30H	624-0600-7	130(30)	41.8		65
* XG1-156P/36-30H	TBD	156(36)	51.8		78
* XG1-208P/48-30H	TBD	208(48)	65.8		104
XG1-260P/60-30H	624-0601-0	260(60)	79.8	130	
* XG1-52P/12-38H	TBD	52(12)	20.8	27.3	26
* XG1-78P/18-38H	TBD	78(18)	27.8		39
* XG1-104P/24-38H	TBD	104(24)	34.8		52
XG1-130P/30-38H	624-0603-5	130(30)	41.8		65
* XG1-156P/36-38H	TBD	156(36)	51.8		78
* XG1-208P/48-38H	TBD	208(48)	65.8		104
* XG1-260P/60-38H	TBD	260(60)	79.8	130	

* Please contact us.

◆ Guide, Guide pin

● Guide (XG1-GS)

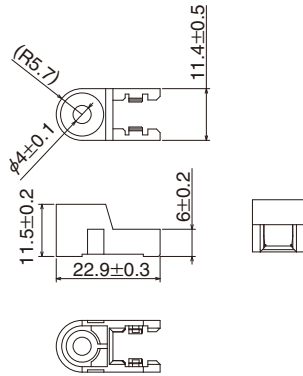

● Guide pin (XG1-GP-*H)

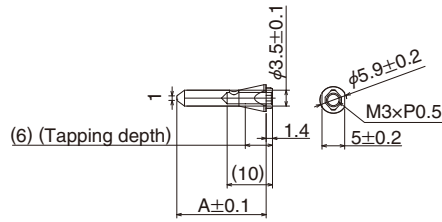

All dimensions in mm

Stacking height	A
20mm	19.7
30mm	29.7
38mm	38.7

● Mated condition

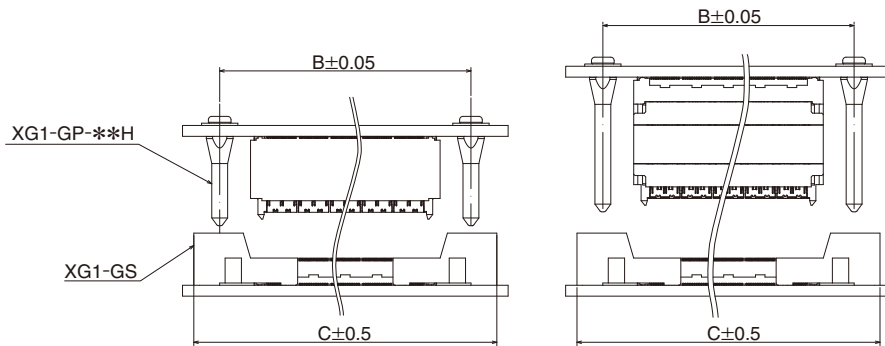

All dimensions in mm

Number of contacts	B	C
78pos	41.4	52.82
104pos	48.4	59.82
130pos	55.4	66.82
156pos	65.4	76.82
208pos	79.4	90.82
260pos	93.4	104.82

● Attachment of guides

Attach guides on receptacle from vertical direction.

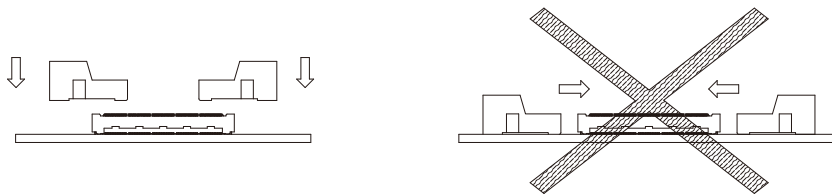

◆ Interposer removal tool

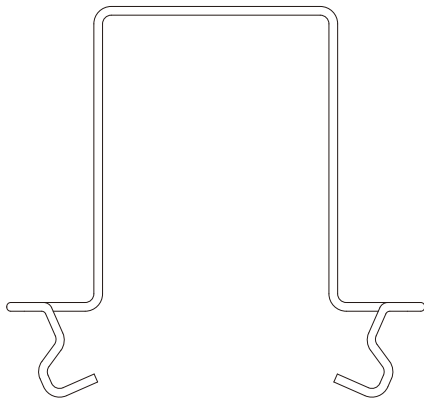

● Removal of the interposer

Set both tips of the removal tool in the cavities of the interposer and pick out the interposer with the tool.

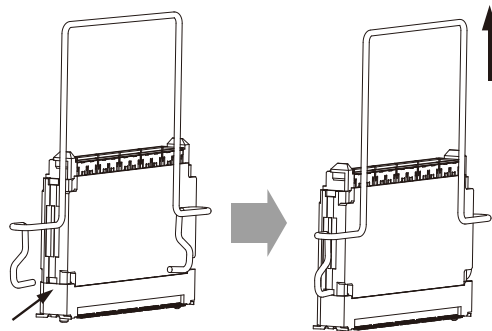

Recommended PCB mounting pattern

Receptacle

Number of Contact : 52 to 130

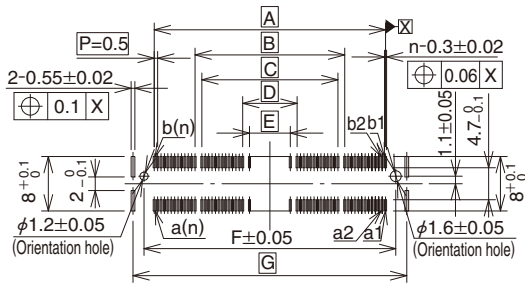

Number of Contact : 156 to 260

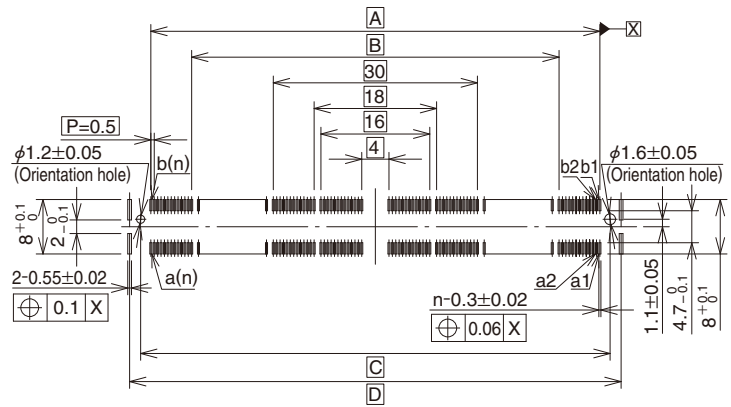

Plug

Number of Contact : 52 to 130

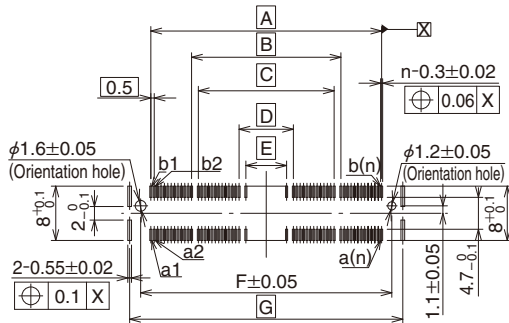

Number of Contact : 156 to 260

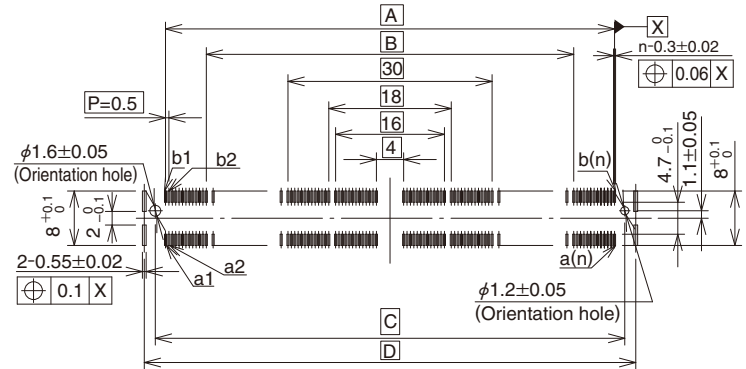

All dimensions in mm

Contact positions	52pos.	78pos.	104pos.	130pos.
A	13	20	27	34
B	1	8	15	22
C	—	6	13	20
D	—	—	1	8
E	—	—	—	6
F	16	23	30	37
G	19.24	26.24	33.24	40.24
n	26	39	52	65

Contact positions	156pos.	208pos.	260pos.
A	44	58	72
B	32	46	60
C	45.35	59.35	73.35
D	47	61	75
n	78	104	130

Pin assignment

Pin No.	Ground	Pin No.	Signal
a1 / b1	Ground	a18 / b18	Signal
a2 / b2	Signal	a19 / b19	Signal
a3 / b3	Signal	a20 / b20	Ground
a4 / b4	Signal	a21 / b21	Signal
a5 / b5	Signal	a22 / b22	Signal
a6 / b6	Signal	a23 / b23	Signal
a7 / b7	Ground	a24 / b24	Signal
a8 / b8	Signal	a25 / b25	Signal
a9 / b9	Signal	a26 / b26	Ground
a10 / b10	Signal	.	.
a11 / b11	Signal	.	.
a12 / b12	Signal	.	.
a13 / b13	Ground	.	.
a14 / b14	Ground	.	.
a15 / b15	Signal	a(n / 2-1) / b(n/2-1)	Signal
a16 / b16	Signal	a(n / 2) / b(n/2)	Ground
a17 / b17	Signal		

Recommended Temperature Profile

Using Lead-free solderpaste

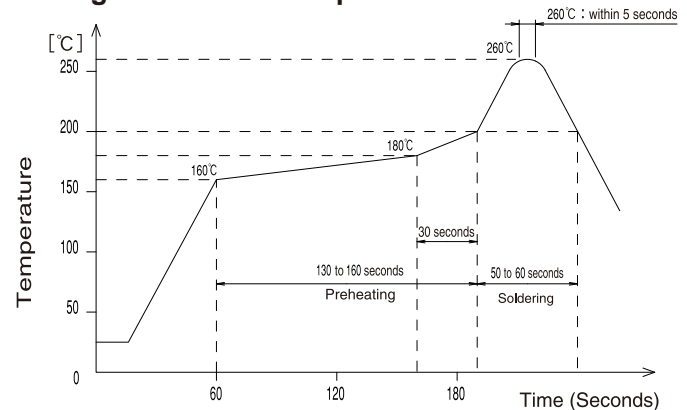

In individual applications the actual temperature may vary, depending on solder paste type, Volume/thickness and board size/thickness. Consult your solder paste and equipment manufacturer for specific recommendations.

Recommended Stencil Dimensions

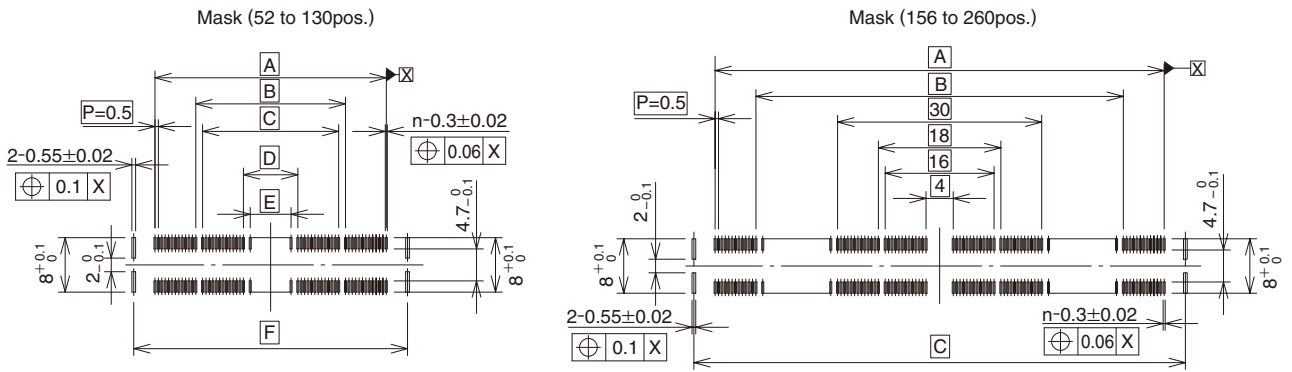

All dimensions in mm

Contact positions	52pos.	78pos.	104pos.	130pos.
A	13	20	27	34
B	1	8	15	22
C	—	6	13	20
D	—	—	1	8
E	—	—	—	6
F	19.24	26.24	33.24	40.24
n	26	39	52	65

Contact positions	156pos.	208pos.	260pos.
A	44	58	72
B	32	46	60
C	47	61	75
n	78	104	130

Recommended Spacer Height

All dimensions : mm

Board-to-board Distance	Part No.	Recommended Spacer Height
20mm	XG1-***P/**-20H-SV	20±0.127
30mm	XG1-***P/**-30H	30±0.127
35mm	XG1-***P/**-35H	35±0.127
38mm	XG1-***P/**-38H	38±0.127

Cleaning recommendations

Organic solvent cleaning

Solvent Type	Room temperature cleaning	Heated cleaning
IPA (Isopropyl alcohol)	YES	YES
HCFC (Hydro chlorofluorocarbon)	YES	YES

Water based cleaning

When using water based cleaning agents (e.g., terpene, alkali saponifiers), select the cleaning agent based on the documentation issued by the various manufacturers of cleaning agents which describes it's affects on metals, platings and plastics. Remove any moisture after cleaning.

Residual flux or cleaning agents in the contact areas may affect electrical performance.



HIROSE ELECTRIC CO.,LTD.

2-6-3,Nakagawa Chuoh,Tsuzuki-Ku,Yokohama-Shi 224-8540,JAPAN

TEL: +81-45-620-3526 Fax: +81-45-591-3726

<http://www.hirose.com>

<http://www.hirose-connectors.com>