



# FOD2742A, FOD2742B, FOD2742C Optically Isolated Error Amplifier

## Features

- Optocoupler, precision reference and error amplifier in single package
- 2.5V reference
- CTR 100% to 200%
- 2,500V RMS isolation
- UL approval E90700, Volume 2
- BSI approval 8661, 8662
- VDE approval 136616
- CSA approval 1113643
- Low temperature coefficient 50 ppm/°C max.
- FOD2742A: tolerance 0.5%  
FOD2742B: tolerance 1%  
FOD2742C: tolerance 2%

## Applications

- Power supplies regulation
- DC to DC converters

## Description

The FOD2742 Optically Isolated Amplifier consists of the popular KA431 precision programmable shunt reference and an optocoupler. The optocoupler is a gallium arsenide (GaAs) light emitting diode optically coupled to a silicon phototransistor. It comes in 3 grades of reference voltage tolerance = 2%, 1%, and 0.5%.

The Current Transfer Ratio (CTR) ranges from 100% to 200%. It also has an outstanding temperature coefficient of 50 ppm/°C. It is primarily intended for use as the error amplifier/reference voltage/optocoupler function in isolated ac to dc power supplies and dc/dc converters.

When using the FOD2742, power supply designers can reduce the component count and save space in tightly packaged designs. The tight tolerance reference eliminates the need for adjustments in many applications. The device comes in a 8-pin small outline package.

## Schematic

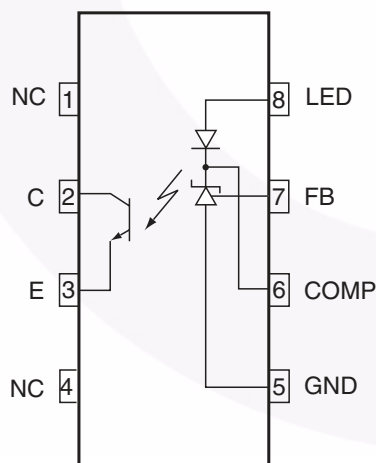

## Package Outline

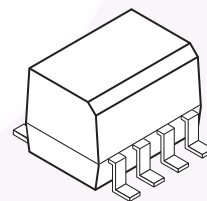

### Pin Definitions

Pin Number	Pin Name	Functional Description
1	NC	Not connected
2	C	Phototransistor Collector
3	E	Phototransistor Emitter
4	NC	Not connected
5	GND	Ground
6	COMP	Error Amplifier Compensation. This pin is the output of the error amplifier.*
7	FB	Voltage Feedback. This pin is the inverting input to the error amplifier
8	LED	Anode LED. This pin is the input to the light emitting diode.

\*The compensation network must be attached between pins 6 and 7.

### Typical Application

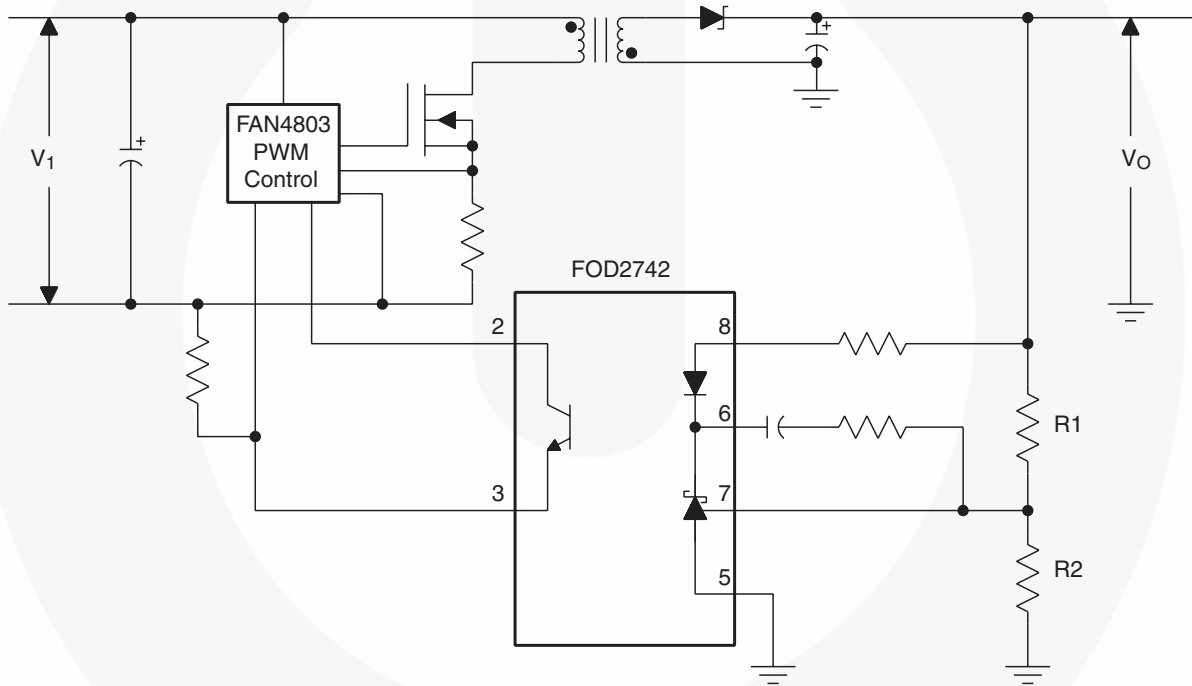

**Absolute Maximum Ratings** ( $T_A = 25^\circ\text{C}$  unless otherwise specified)

Stresses exceeding the absolute maximum ratings may damage the device. The device may not function or be operable above the recommended operating conditions and stressing the parts to these levels is not recommended. In addition, extended exposure to stresses above the recommended operating conditions may affect device reliability. The absolute maximum ratings are stress ratings only.

Symbol	Parameter	Value	Units
$T_{\text{STG}}$	Storage Temperature	-40 to +125	$^\circ\text{C}$
$T_{\text{OPR}}$	Operating Temperature	-25 to +85	$^\circ\text{C}$
	Reflow Temperature Profile (refer to 15)		
$V_{\text{LED}}$	Input Voltage	37	V
$I_{\text{LED}}$	Input DC Current	20	mA
$V_{\text{CEO}}$	Collector-Emitter Voltage	70	V
$V_{\text{ECO}}$	Emitter-Collector Voltage	7	V
$I_{\text{C}}$	Collector Current	50	mA
PD1	Input Power Dissipation <sup>(1)</sup>	145	mW
PD2	Transistor Power Dissipation <sup>(2)</sup>	85	mW
PD3	Total Power Dissipation <sup>(3)</sup>	145	mW

**Notes:**

1. Derate linearly from  $25^\circ\text{C}$  at a rate of  $2.42\text{mW}/^\circ\text{C}$
2. Derate linearly from  $25^\circ\text{C}$  at a rate of  $1.42\text{mW}/^\circ\text{C}$ .
3. Derate linearly from  $25^\circ\text{C}$  at a rate of  $2.42\text{mW}/^\circ\text{C}$ .

## Electrical Characteristics (T<sub>A</sub> = 25°C unless otherwise specified)

### Input Characteristics

Symbol	Parameter	Test Conditions	Device	Min.	Typ.	Max.	Unit
V <sub>F</sub>	LED Forward Voltage	I <sub>LED</sub> = 10mA, V <sub>COMP</sub> = V <sub>FB</sub> (Fig. 1)	All		1.20	1.5	V
V <sub>REF</sub>	Reference Voltage	I <sub>LED</sub> = 10mA, V <sub>COMP</sub> = V <sub>FB</sub> (Fig. 1)	A	2.482	2.495	2.508	V
			B	2.470	2.495	2.520	V
			C	2.450	2.500	2.550	V
V <sub>REF (DEV)</sub>	Deviation of V <sub>REF</sub> Over Temperature	T <sub>A</sub> = -25°C to +85°C (Fig. 1)	All		3.5	17	mV
$\frac{\Delta V_{RE}}{\Delta V_{COMP}}$	Ratio of V <sub>REF</sub> Variation to the Output of the Error Amplifier	I <sub>LED</sub> = 10mA (Fig. 2) $\Delta V_{COMP} = 10V$ to V <sub>REF</sub> $\Delta V_{COMP} = 36V$ to 10V	All		-0.5	-2.7	mV/ V
I <sub>REF</sub>	Feedback Input Current	I <sub>LED</sub> = 10mA, R <sub>1</sub> = 10KΩ (Fig. 3)	All		2.2	4	μA
I <sub>REF (DEV)</sub>	Deviation of I <sub>REF</sub> Over Temperature	T <sub>A</sub> = -25°C to +85°C (Fig. 3)	All		1.0	1.2	μA
I <sub>LED (MIN)</sub>	Minimum Drive Current	V <sub>COMP</sub> = V <sub>FB</sub> (Fig. 1)	All		0.45	1.0	mA
I <sub>(OFF)</sub>	Off-state Error Amplifier Current	V <sub>LED</sub> = 37V, V <sub>FB</sub> = 0 (Fig. 4)	All		0.01	1.0	μA
Z <sub>OUT</sub>	Error Amplifier Output Impedance (see note 2)	V <sub>COMP</sub> = V <sub>REF</sub> , I <sub>LED</sub> = 1mA to 20mA, f ≥ 1.0kHz	All		0.15	0.5	Ω

#### Notes:

- The deviation parameters V<sub>REF(DEV)</sub> and I<sub>REF(DEV)</sub> are defined as the differences between the maximum and minimum values obtained over the rated temperature range. The average full-range temperature coefficient of the reference input voltage, ΔV<sub>REF</sub>, is defined as:

$$|\Delta V_{REF}|(\text{ppm}/^\circ\text{C}) = \frac{\{V_{REF(DEV)}/V_{REF}(T_A = 25^\circ\text{C})\} \times 10^6}{\Delta T_A}$$

where ΔT<sub>A</sub> is the rated operating free-air temperature range of the device.

- The dynamic impedance is defined as |Z<sub>OUT</sub>| = ΔV<sub>COMP</sub>/ΔI<sub>LED</sub>. When the device is operating with two external resistors (see Figure 2), the total dynamic impedance of the circuit is given by:

$$|Z_{OUT, TOT}| = \frac{\Delta V}{\Delta I} \approx |Z_{OUT}| \times \left[ 1 + \frac{R1}{R2} \right]$$

**Electrical Characteristics** ( $T_A = 25^\circ\text{C}$  unless otherwise specified) (Continued)**Output Characteristics**

Symbol	Parameter	Test Conditions	Min.	Typ.	Max.	Unit
$I_{CEO}$	Collector Dark Current	$V_{CE} = 10\text{V}$ (Fig. 5)		1	50	nA
$BV_{ECO}$	Emitter-Collector Voltage Breakdown	$I_E = 100\mu\text{A}$	7	10		V
$BV_{CEO}$	Collector-Emitter Voltage Breakdown	$I_C = 1.0\text{mA}$	70	120		V

**Transfer Characteristics**

Symbol	Parameter	Test Conditions	Min.	Typ.	Max.	Unit
CTR	Current Transfer Ratio	$I_{LED} = 10\text{mA}$ , $V_{COMP} = V_{FB}$ , $V_{CE} = 5\text{V}$ (Fig. 6)	100	140	200	%
$V_{CE(SAT)}$	Collector-Emitter Saturation Voltage	$I_{LED} = 10\text{mA}$ , $V_{COMP} = V_{FB}$ , $I_C = 2.5\text{mA}$ (Fig. 6)		0.16	0.4	V

**Isolation Characteristics**

Symbol	Parameter	Test Conditions	Min.	Typ.	Max.	Unit
$I_{I-O}$	Input-Output Insulation Leakage Current	$RH = 45\%$ , $T_A = 25^\circ\text{C}$ , $t = 5\text{s}$ , $V_{I-O} = 3000\text{VDC}$ (Note 1)			1.0	$\mu\text{A}$
$V_{ISO}$	Withstand Insulation Voltage	$RH \leq 50\%$ , $T_A = 25^\circ\text{C}$ , $t = 1\text{ min.}$ (Note 1)	2500			Vrms
$R_{I-O}$	Resistance (Input to Output)	$V_{I-O} = 500\text{VDC}$ (Note 1)		$10^{12}$		$\Omega$

**Switching Characteristics**

Symbol	Parameter	Test Conditions	Min.	Typ.	Max.	Unit
$B_W$	Bandwidth	Fig. 7		50		kHz
$ CMH $	Common Mode Transient Immunity at Output HIGH	$I_{LED} = 0\text{mA}$ , $ V_{cm}  = 10\text{V}_{PP}$ $RL = 2.2\text{k}\Omega$ (Fig. 8) (Note 2)		1.0		$\text{kV}/\mu\text{s}$
$ CML $	Common Mode Transient Immunity at Output LOW	$I_{LED} = 10\text{mA}$ , $ V_{cm}  = 10\text{V}_{PP}$ $RL = 2.2\text{k}\Omega$ (Fig. 8) (Note 2)		1.0		$\text{kV}/\mu\text{s}$

**Notes:**

- Device is considered as a two terminal device: Pins 1, 2, 3 and 4 are shorted together and Pins 5, 6, 7 and 8 are shorted together.
- Common mode transient immunity at output high is the maximum tolerable (positive)  $dV_{cm}/dt$  on the leading edge of the common mode impulse signal,  $V_{cm}$ , to assure that the output will remain high. Common mode transient immunity at output low is the maximum tolerable (negative)  $dV_{cm}/dt$  on the trailing edge of the common pulse signal,  $V_{cm}$ , to assure that the output will remain low.

## Test Circuits

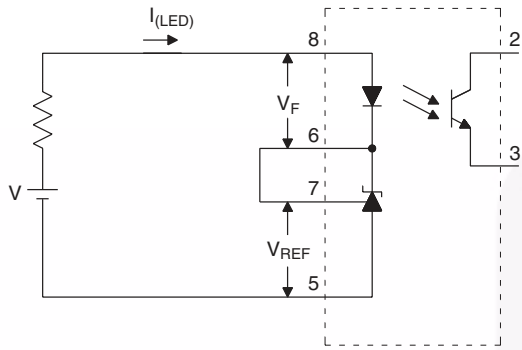

Figure 1.  $V_{REF}$ ,  $V_F$ ,  $I_{LED}$  (min) Test Circuit

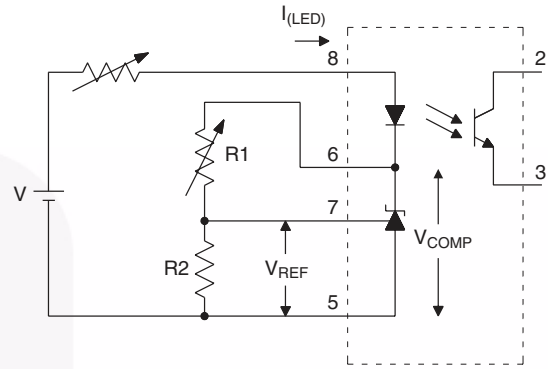

Figure 2.  $\Delta V_{REF}/\Delta V_{COMP}$  Test Circuit

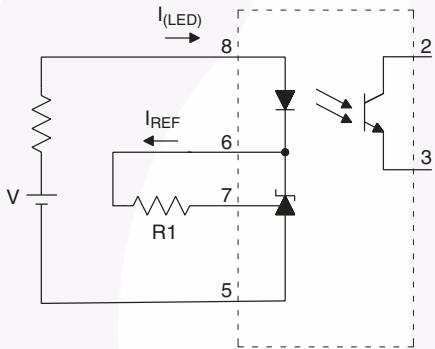

Figure 3.  $I_{REF}$  Test Circuit

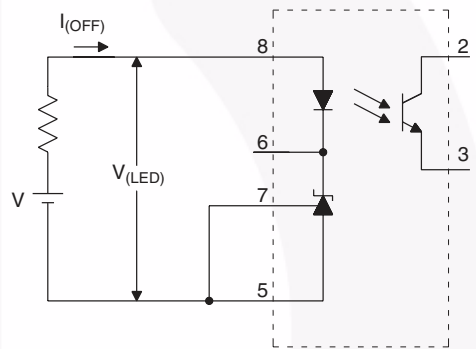

Figure 4.  $I_{(OFF)}$  Test Circuit

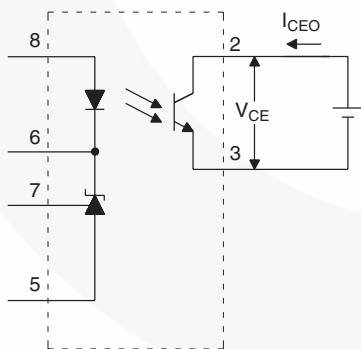

Figure 5.  $I_{CEO}$  Test Circuit

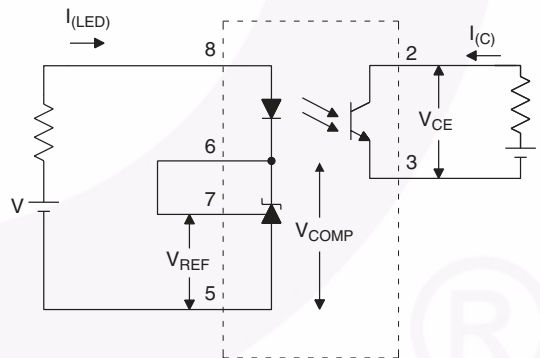

Figure 6.  $CTR$ ,  $V_{CE(sat)}$  Test Circuit

Test Circuits (Continued)

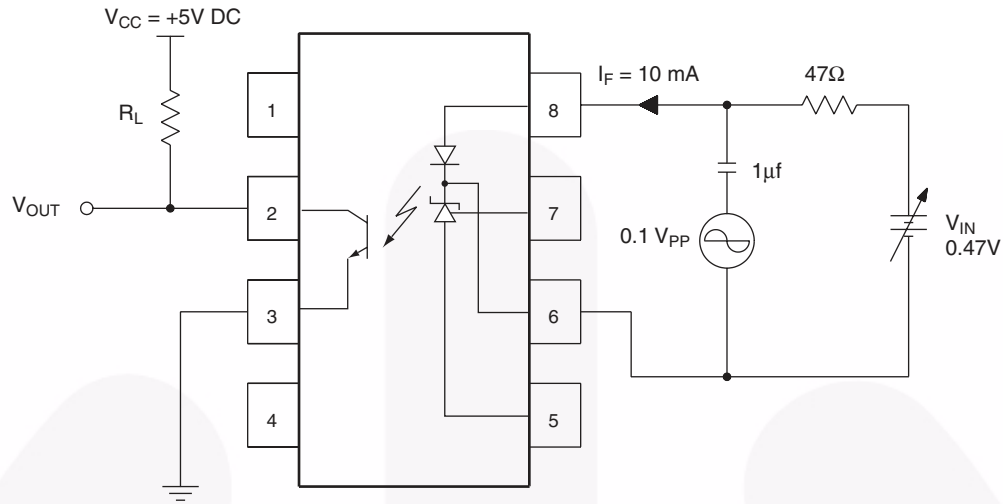

Figure 7. Frequency Response Test Circuit

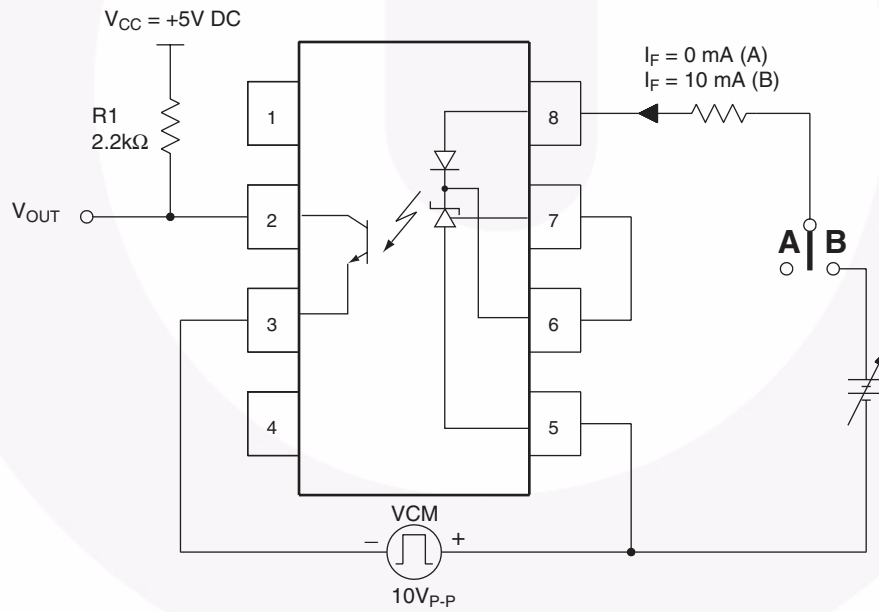

Figure 8. CMH and CML Test Circuit

## Typical Performance Curves

Fig. 9a LED Current vs. Cathode Voltage

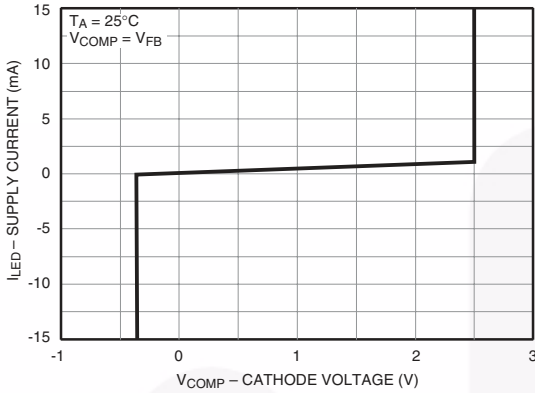

Fig. 9b LED Current vs. Cathode Voltage

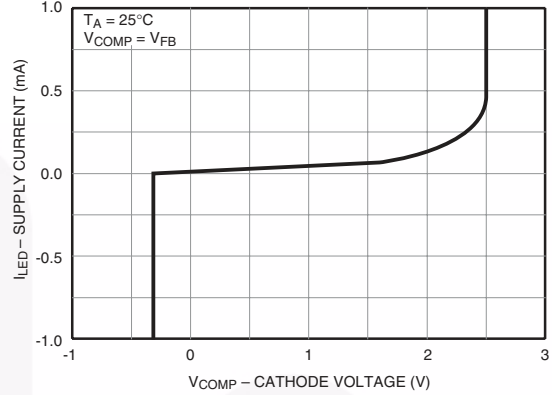

Fig. 10 Reference Voltage vs. Ambient Temperature

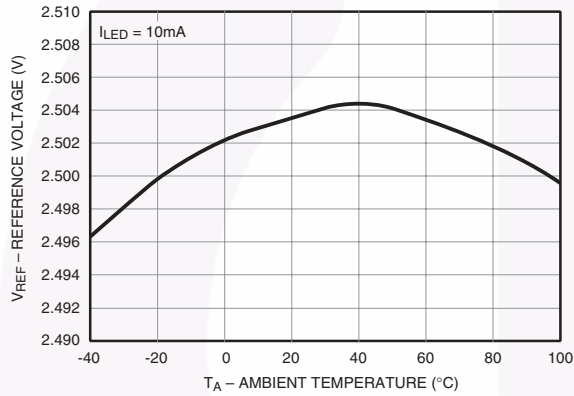

Fig. 11 Reference Current vs. Ambient Temperature

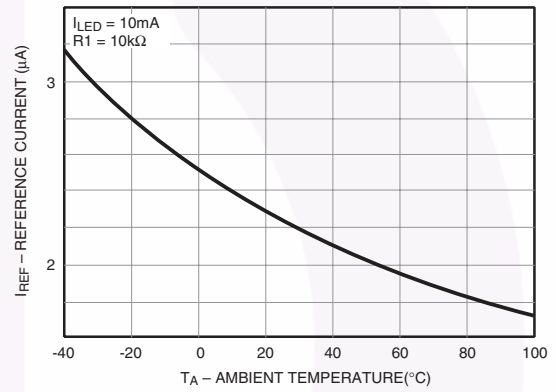

Fig. 12 Off-State Current vs. Ambient Temperature

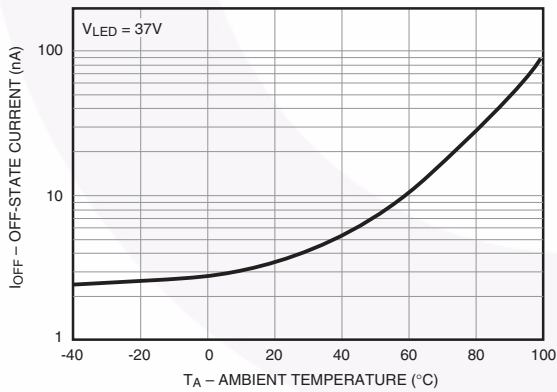
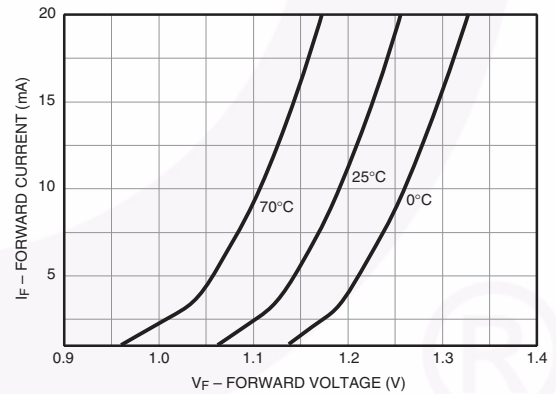
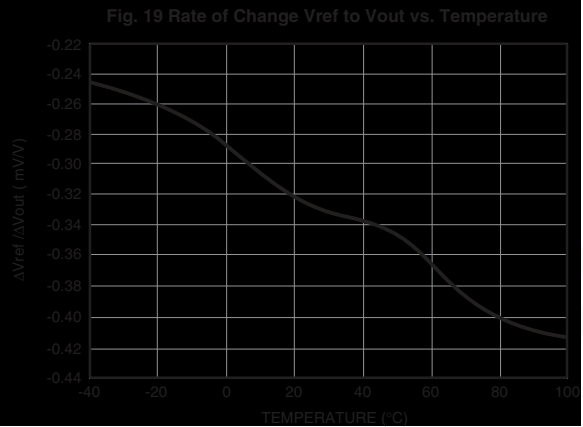
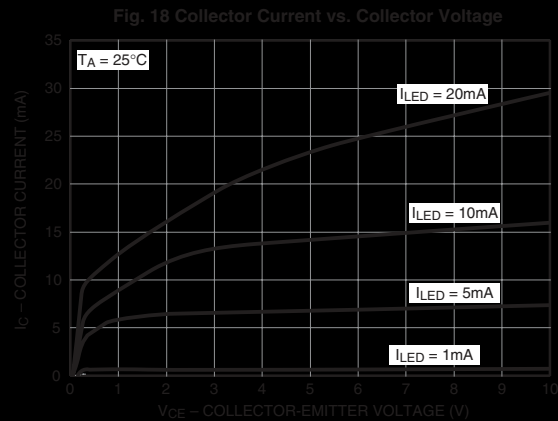
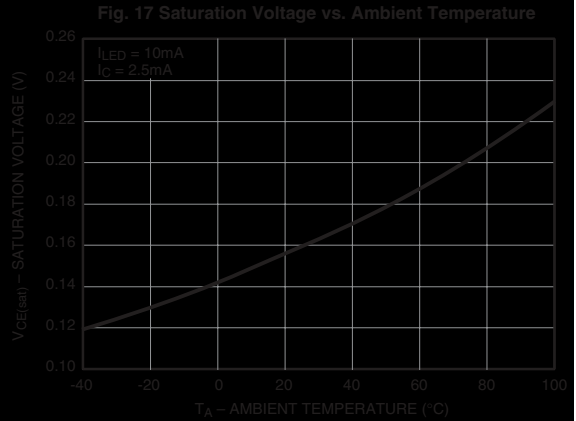
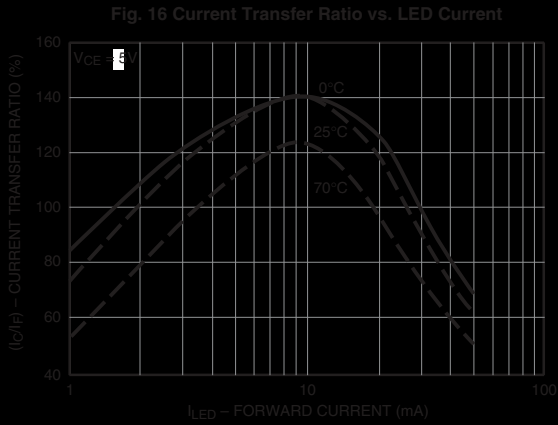
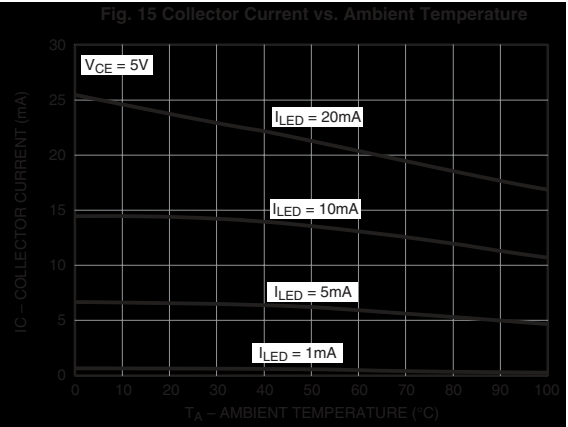
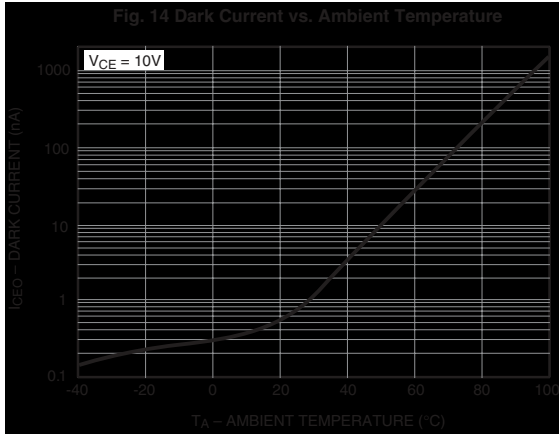

Fig. 13 Forward Current vs. Forward Voltage





Typical Performance Curves (Continued)



### Typical Performance Curves (Continued)

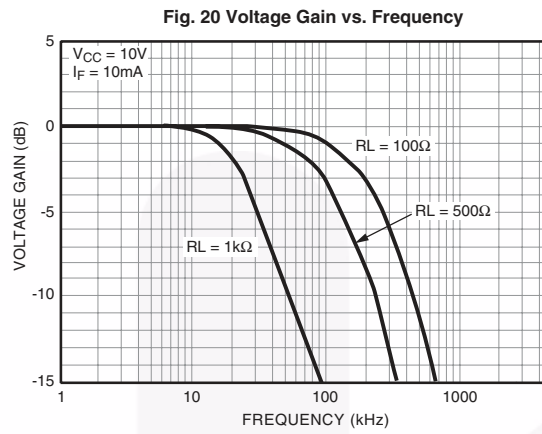

## The FOD2742

The FOD2742 is an optically isolated error amplifier. It incorporates three of the most common elements necessary to make an isolated power supply, a reference voltage, an error amplifier, and an optocoupler. It is functionally equivalent to the popular KA431 shunt voltage regulator plus the CNY17F-X optocoupler.

### Powering the Secondary Side

The LED pin in the FOD2742 powers the secondary side, and in particular provides the current to run the LED. The actual structure of the FOD2742 dictates the minimum voltage that can be applied to the LED pin: The error amplifier output has a minimum of the reference voltage, and the LED is in series with that. Minimum voltage applied to the LED pin is thus  $2.5V + 1.5V = 4.0V$ . This voltage can be generated either directly from the output of the converter, or else from a slaved secondary winding. The secondary winding will not affect regulation, as the input to the FB pin may still be taken from the output winding.

The LED pin needs to be fed through a current limiting resistor. The value of the resistor sets the amount of current through the LED, and thus must be carefully selected in conjunction with the selection of the primary side resistor.

### Feedback

Output voltage of a converter is determined by selecting a resistor divider from the regulated output to the FB pin. The FOD2742 attempts to regulate its FB pin to the reference voltage, 2.5V. The ratio of the two resistors should thus be:

$$\frac{R_{TOP}}{R_{BOTTOM}} = \frac{V_{OUT}}{V_{REF}} - 1$$

The absolute value of the top resistor is set by the input offset current of  $5.2\mu A$ . To achieve 0.5% accuracy, the resistance of  $R_{TOP}$  should be:

$$\frac{V_{OUT} - 2.5}{R_{TOP}} > 1040\mu A$$

## Compensation

The compensation pin of the FOD2742 provides the opportunity for the designer to design the frequency response of the converter. A compensation network may be placed between the COMP pin and the FB pin. In typical low-bandwidth systems, a  $0.1\mu F$  capacitor may be used. For converters with more stringent requirements, a network should be designed based on measurements of the system's loop. An excellent reference for this process may be found in "Practical Design of Power Supplies" by Ron Lenk, IEEE Press, 1998.

### Secondary Ground

The GND pin should be connected to the secondary ground of the converter.

### No Connect Pins

The NC pins have no internal connection. They should not have any connection to the secondary side, as this may compromise the isolation structure.

### Photo-Transistor

The Photo-transistor is the output of the FOD2742. In a normal configuration the collector will be attached to a pull-up resistor and the emitter grounded. There is no base connection necessary.

The value of the pull-up resistor, and the current limiting resistor feeding the LED, must be carefully selected to account for voltage range accepted by the PWM IC, and for the variation in current transfer ratio (CTR) of the opto-isolator itself.

**Example:** The voltage feeding the LED pins is +12V, the voltage feeding the collector pull-up is +10V, and the PWM IC is the Fairchild KA1H0680, which has a 5V reference. If we select a 10KV resistor for the LED, the maximum current the LED can see is:

$$(12V - 4V) / 10K\Omega = 800\mu A.$$

The CTR of the opto-isolator is a minimum of 100%, so the minimum collector current of the photo-transistor when the diode is full on is also  $800\mu A$ . The collector resistor must thus be such that:

$$\frac{10V - 5V}{R_{COLLECTOR}} < 800\mu A \text{ or } R_{COLLECTOR} > 6.25K\Omega;$$

select 12K $\Omega$  to allow some margin.

### Ordering Information

Option	Order Entry Identifier	Description
V	V	VDE 0884
R2	R2	Tape and reel (2500 units per reel)
R2V	R2V	VDE 0884, Tape and reel (2500 units per reel)

### Marking Information

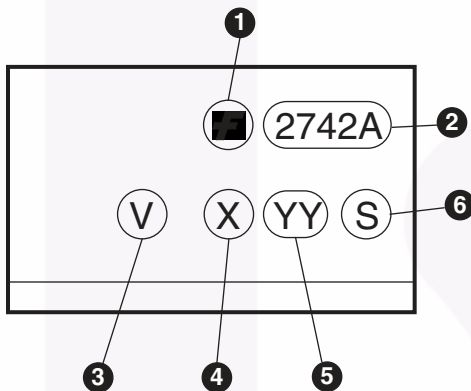

Definitions	
1	Fairchild logo
2	Device number
3	VDE mark (Note: Only appears on parts ordered with VDE option – See order entry table)
4	One digit year code, e.g., '3'
5	Two digit work week ranging from '01' to '53'
6	Assembly package code

### Carrier Tape Specifications

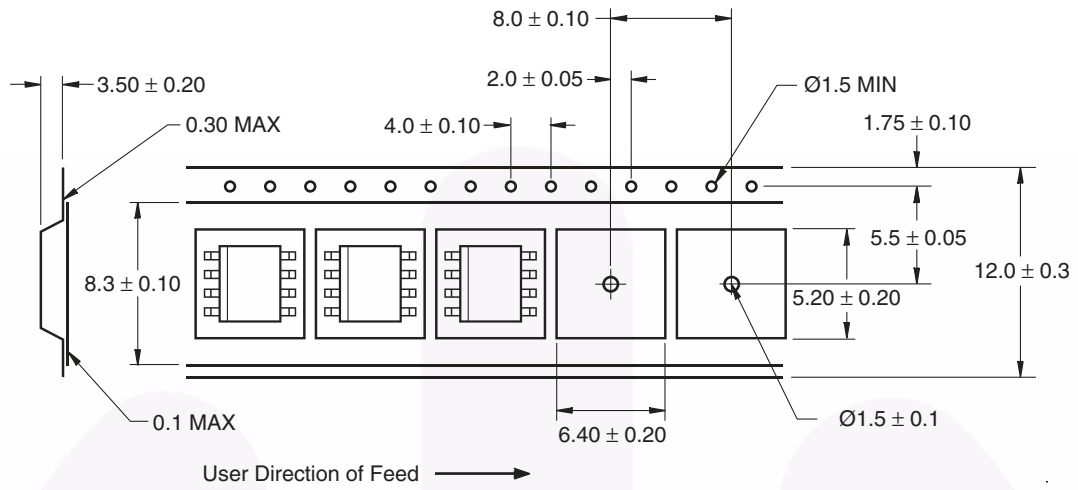

Dimensions in mm

## Reflow Profile

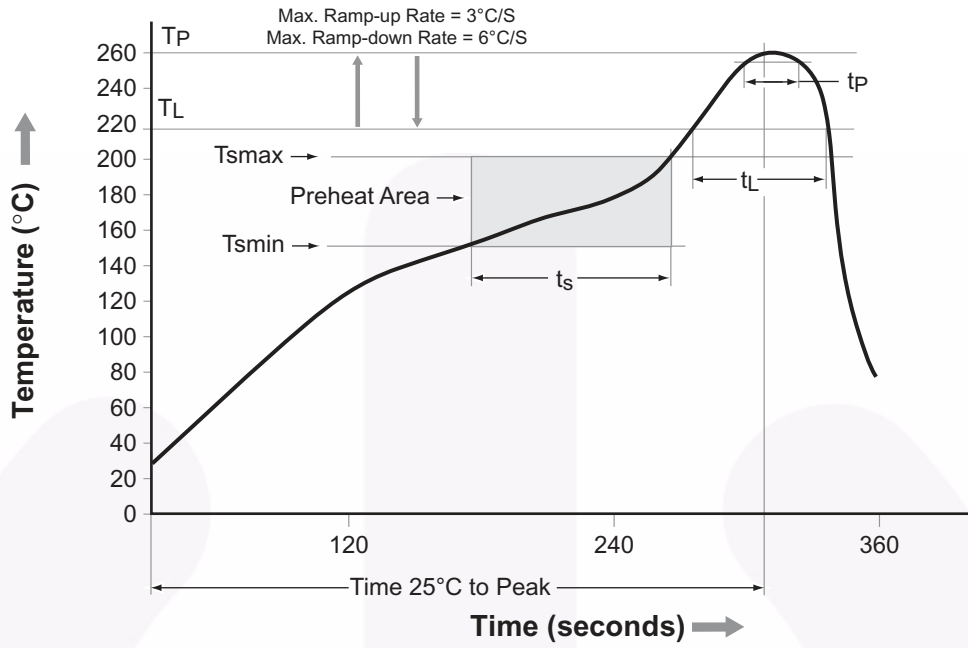

Profile Feature	Pb-Free Assembly Profile
Temperature Min. (T <sub>smín</sub> )	150°C
Temperature Max. (T <sub>smáx</sub> )	200°C
Time (t <sub>s</sub> ) from (T <sub>smín</sub> to T <sub>smáx</sub> )	60–120 seconds
Ramp-up Rate (t <sub>L</sub> to t <sub>p</sub> )	3°C/second max.
Liquidous Temperature (T <sub>L</sub> )	217°C
Time (t <sub>L</sub> ) Maintained Above (T <sub>L</sub> )	60–150 seconds
Peak Body Package Temperature	260°C +0°C / -5°C
Time (t <sub>p</sub> ) within 5°C of 260°C	30 seconds
Ramp-down Rate (T <sub>p</sub> to T <sub>L</sub> )	6°C/second max.
Time 25°C to Peak Temperature	8 minutes max.

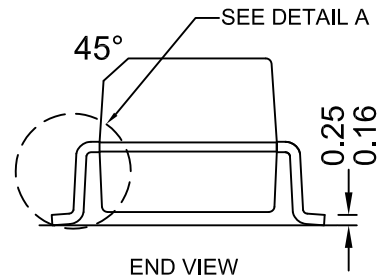
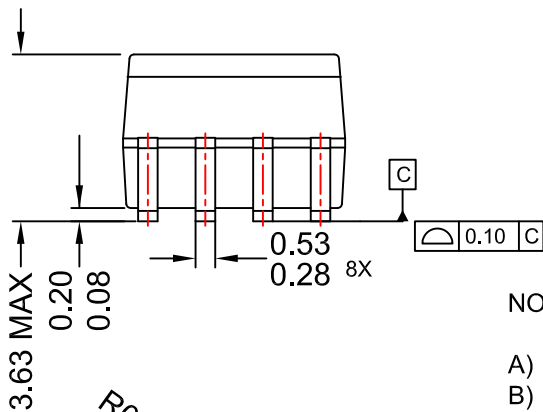
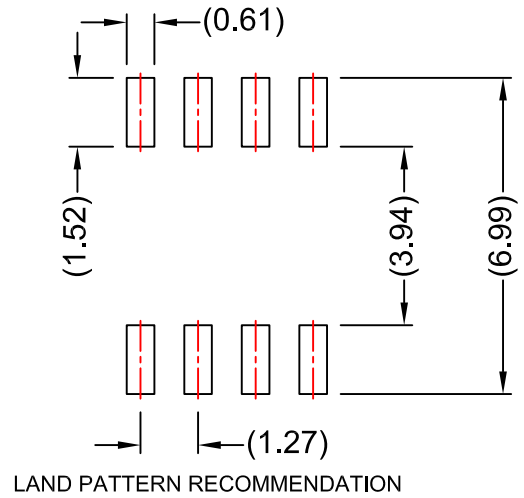
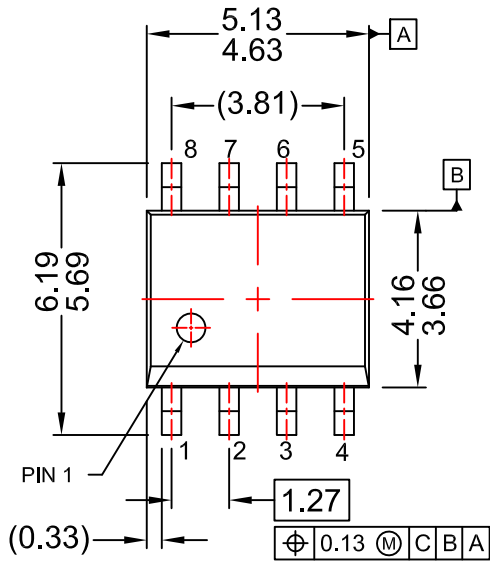

NOTES:

- A) NO STANDARD APPLIES TO THIS PACKAGE
- B) ALL DIMENSIONS ARE IN MILLIMETERS.
- C) DIMENSIONS DO NOT INCLUDE MOLD FLASH OR BURRS.
- D) LANDPATTERN STANDARD: SOIC127P600X175-8M.
- E) DRAWING FILENAME: MKT-M08Erev5

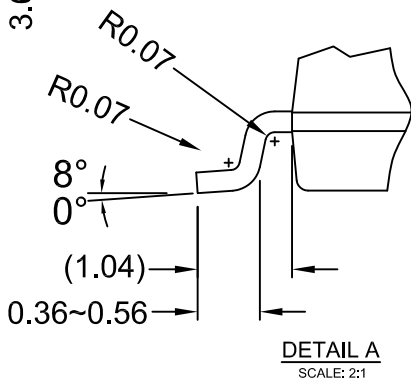





### TRADEMARKS

The following includes registered and unregistered trademarks and service marks, owned by Fairchild Semiconductor and/or its global subsidiaries, and is not intended to be an exhaustive list of all such trademarks.

AccuPower™  
 AttitudeEngine™  
 Awinda®  
 AX-CAP®\*  
 BitSiC™  
 Build it Now™  
 CorePLUS™  
 CorePOWER™  
 CROSSVOL™  
 CTL™  
 Current Transfer Logic™  
 DEUXPEED®  
 Dual Cool™  
 EcoSPARK®  
 EfficientMax™  
 ESBC™  
 F™  
 Fairchild®  
 Fairchild Semiconductor®  
 FACT Quiet Series™  
 FACT®  
 FastvCore™  
 FETBench™  
 FPS™

F-PFS™  
 FRFET®  
 Global Power Resource™  
 GreenBridge™  
 Green FPS™  
 Green FPS™ e-Series™  
 Gmax™  
 GTO™  
 IntelliMAX™  
 ISOPLANAR™  
 Making Small Speakers Sound Louder and Better™  
 MegaBuck™  
 MICROCOUPLER™  
 MicroFET™  
 MicroPak™  
 MicroPak2™  
 MillerDrive™  
 MotionMax™  
 MotionGrid®  
 MTi®  
 MTx®  
 MVN®  
 mWSaver®  
 OptoHiT™  
 OPTOLOGIC®

OPTOPLANAR®  
®  
 Power Supply WebDesigner™  
 PowerTrench®  
 PowerXS™  
 Programmable Active Droop™  
 QFET®  
 QS™  
 Quiet Series™  
 RapidConfigure™  
™  
 Saving our world, 1mW/W/kW at a time™  
 SignalWise™  
 SmartMax™  
 SMART START™  
 Solutions for Your Success™  
 SPM®  
 STEALTH™  
 SuperFET®  
 SuperSOT™-3  
 SuperSOT™-6  
 SuperSOT™-8  
 SupreMOS®  
 SyncFET™  
 Sync-Lock™

 SYSTEM GENERAL®  
 TinyBoost®  
 TinyBuck®  
 TinyCalc™  
 TinyLogic®  
 TINYOPTO™  
 TinyPower™  
 TinyPWM™  
 TinyWire™  
 TranSiC™  
 TriFault Detect™  
 TRUECURRENT®\*  
 μSerDes™  
 SerDes™  
 UHC®  
 Ultra FRFET™  
 UniFET™  
 VCX™  
 VisualMax™  
 VoltagePlus™  
 XS™  
 Xsens™  
 仙童®

\* Trademarks of System General Corporation, used under license by Fairchild Semiconductor.

### DISCLAIMER

FAIRCHILD SEMICONDUCTOR RESERVES THE RIGHT TO MAKE CHANGES WITHOUT FURTHER NOTICE TO ANY PRODUCTS HEREIN TO IMPROVE RELIABILITY, FUNCTION, OR DESIGN. TO OBTAIN THE LATEST, MOST UP-TO-DATE DATASHEET AND PRODUCT INFORMATION, VISIT OUR WEBSITE AT [HTTP://WWW.FAIRCHILDSEMI.COM](http://www.fairchildsemi.com). FAIRCHILD DOES NOT ASSUME ANY LIABILITY ARISING OUT OF THE APPLICATION OR USE OF ANY PRODUCT OR CIRCUIT DESCRIBED HEREIN; NEITHER DOES IT CONVEY ANY LICENSE UNDER ITS PATENT RIGHTS, NOR THE RIGHTS OF OTHERS. THESE SPECIFICATIONS DO NOT EXPAND THE TERMS OF FAIRCHILD'S WORLDWIDE TERMS AND CONDITIONS, SPECIFICALLY THE WARRANTY THEREIN, WHICH COVERS THESE PRODUCTS.

### AUTHORIZED USE

Unless otherwise specified in this data sheet, this product is a standard commercial product and is not intended for use in applications that require extraordinary levels of quality and reliability. This product may not be used in the following applications, unless specifically approved in writing by a Fairchild officer: (1) automotive or other transportation, (2) military/aerospace, (3) any safety critical application – including life critical medical equipment – where the failure of the Fairchild product reasonably would be expected to result in personal injury, death or property damage. Customer's use of this product is subject to agreement of this Authorized Use policy. In the event of an unauthorized use of Fairchild's product, Fairchild accepts no liability in the event of product failure. In other respects, this product shall be subject to Fairchild's Worldwide Terms and Conditions of Sale, unless a separate agreement has been signed by both Parties.

### ANTI-COUNTERFEITING POLICY

Fairchild Semiconductor Corporation's Anti-Counterfeiting Policy. Fairchild's Anti-Counterfeiting Policy is also stated on our external website, [www.fairchildsemi.com](http://www.fairchildsemi.com), under Terms of Use

Counterfeiting of semiconductor parts is a growing problem in the industry. All manufacturers of semiconductor products are experiencing counterfeiting of their parts. Customers who inadvertently purchase counterfeit parts experience many problems such as loss of brand reputation, substandard performance, failed applications, and increased cost of production and manufacturing delays. Fairchild is taking strong measures to protect ourselves and our customers from the proliferation of counterfeit parts. Fairchild strongly encourages customers to purchase Fairchild parts either directly from Fairchild or from Authorized Fairchild Distributors who are listed by country on our web page cited above. Products customers buy either from Fairchild directly or from Authorized Fairchild Distributors are genuine parts, have full traceability, meet Fairchild's quality standards for handling and storage and provide access to Fairchild's full range of up-to-date technical and product information. Fairchild and our Authorized Distributors will stand behind all warranties and will appropriately address any warranty issues that may arise. Fairchild will not provide any warranty coverage or other assistance for parts bought from Unauthorized Sources. Fairchild is committed to combat this global problem and encourage our customers to do their part in stopping this practice by buying direct or from authorized distributors.

### PRODUCT STATUS DEFINITIONS

#### Definition of Terms

Datasheet Identification	Product Status	Definition
Advance Information	Formative / In Design	Datasheet contains the design specifications for product development. Specifications may change in any manner without notice.
Preliminary	First Production	Datasheet contains preliminary data; supplementary data will be published at a later date. Fairchild Semiconductor reserves the right to make changes at any time without notice to improve design.
No Identification Needed	Full Production	Datasheet contains final specifications. Fairchild Semiconductor reserves the right to make changes at any time without notice to improve the design.
Obsolete	Not In Production	Datasheet contains specifications on a product that is discontinued by Fairchild Semiconductor. The datasheet is for reference information only.

Rev. I77