

REV.	DATE	ECR NO.	DESCRIPTION
NC	02/03/10	XXXXXX	INITIAL RELEASE
A	06/21/10	2059	THE DIMENSION OF .067" WAS CHANGED TO .035"
B	08/13/12	2350	MODIFY LEG PLATING TO IMPROVE SOLDERABILITY; UPDATE DRAWING FORMAT

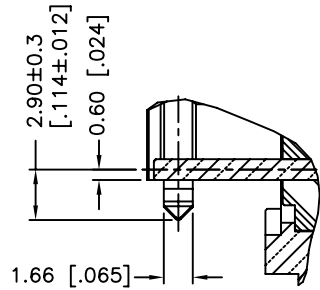

DETAIL B
SCALE 4.000

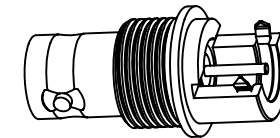
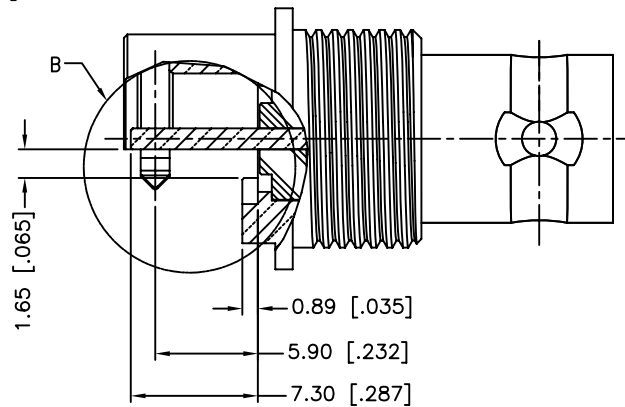
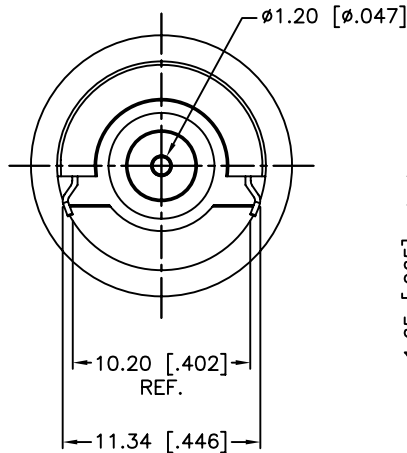
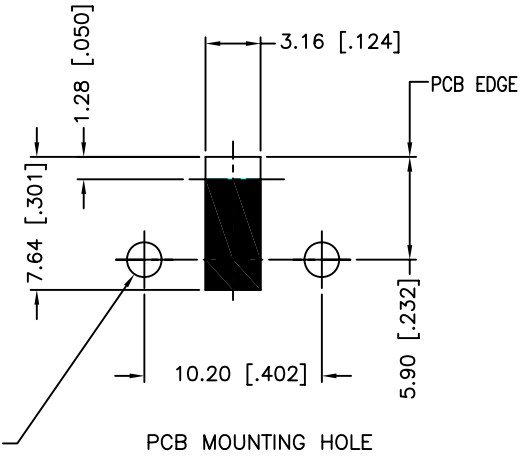
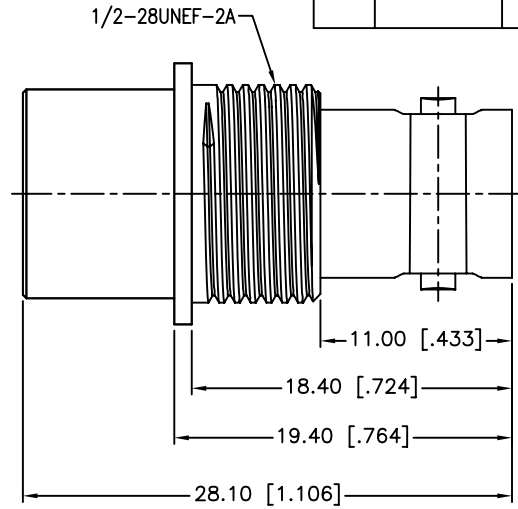

1. IMPEDANCE: 75 OHM
2. FREQUENCY RANGE: DC 0-3 GHz
3. VSWR: 1.15, MAX.
4. DIELECTRIC WITHSTANDING VOLTAGE: 1500 VRMS, MIN.
5. DURABILITY: 500 CYCLES MIN.
6. TEMPERATURE RANGE: -65°C TO +165°C

DESCRIPTION	MATERIAL	FINISH	QTY
6 LEG	301 1/2H STAINLESS STEEL	GOLD	1
5 INSULATOR	PTFE	NATURAL	1
4 CONTACT PIN	PHOSPHOR BRONZE	GOLD	1
3 INSULATOR	PTFE	NATURAL	1
2 LOCK RING	BRASS	NICKEL	1
1 HOUSING	BRASS	NICKEL	1

UNLESS OTHERWISE SPECIFIED DIMENSIONS ARE IN MILLIMETERS. DIMENSIONS IN [] ARE IN INCHES AND FOR CUSTOMER REFERENCE ONLY.		APPROVALS	DATE
UNLESS OTHERWISE SPECIFIED TOLERANCES FOR MILLIMETERS ARE: 0.5 - 8mm ± 0.20mm 8 - 30mm ± 0.40mm 30 - 120mm ± 0.50mm		DRAWN M.ZHANG	08/13/12
UNLESS OTHERWISE SPECIFIED TOLERANCES FOR INCHES ARE: .020 - .315 = ± 0.007" .315 - 1.180 = ± 0.015" 1.180 - 4.724 = ± 0.020"		CHECKED	
DO NOT SCALE DRAWING		ISSUED	
		SHEET 1 OF 1	
		CAD FILE C:/CONNEX/112775-75.DWG	

Amphenol Connex

PART DESCRIPTION			
BNC PCB MOUNT RECEPT. JACK			
PART NO.		112775-75	
DWG. NO.	112775-75 .DWG	REV.	B
SIZE	A	SCALE	NA