

(b) (c)

NOTES:

1. FOR WAVESOLDERING (SOLDER BATH TEMPERATURE 265°C FOR 8 SEC. AND SOLDER PREHEAT 150°C FOR 180 SEC.)
2. IP RATING: IP 67
3. SEALED TO WITHSTAND PRESSURE UP TO 1,45 PSI FOR 30 MINUTES AFTER HIGH TEMPERATURE EXPOSURE
4. METALSHELL: ZINC DIE CAST; min. 50µin NICKEL PLATING over COPPER
5. INSULATORS: PBT GF UL 94 V-0, BLACK
6. O-RING: SILICONE PER ASTM D2000 70 SHORE A
7. SEALING COMPOUND: EPOXY RESIN UL 94 V-0; BLACK
8. CONTACTS: COPPER ALLOY
PLATING (SEE PART NO):
 PLEASE ADD 1 for 30µin HARD GOLD over min. 50µin NICKEL
 PLEASE ADD 3 for 8µin HARD GOLD over min. 50µin NICKEL
9. REAR SPACER CLIPS: COPPER ALLOY; min. 200µin TIN over 80µin NICKEL
PCB-HOLE: $\varnothing 3,1 \pm 0,1$; PCB THICKNES 1,6mm
10. HEXLOCKING SCREWS: STAINLESS STEEL
11. PCB-HOLE DRILLINGS and RECOMMENDED PANEL CUT-OUT ON SHEET 2
12. RECOMMENDED TORQUE FOR MOUNTING SCREW 35Ncm (3.1 in.LB) / max.67Ncm (6 in.LB)
13. CONNECTOR IS PART MARKED: 15-00054 CONEC ABC

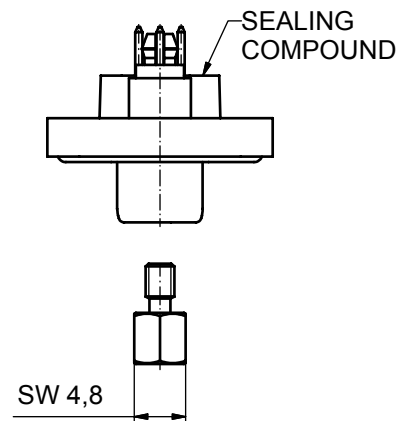
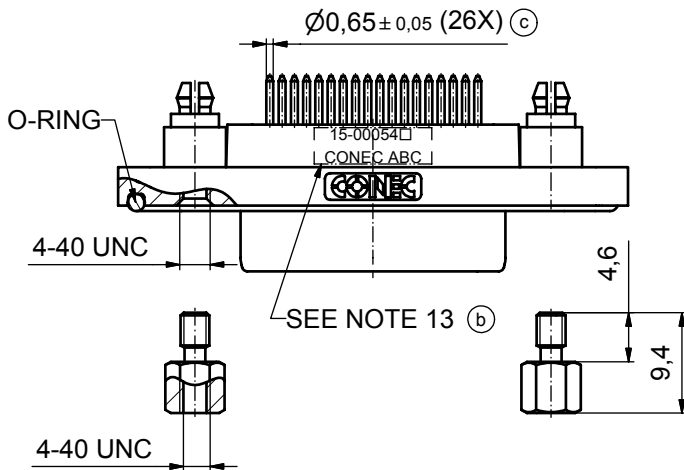
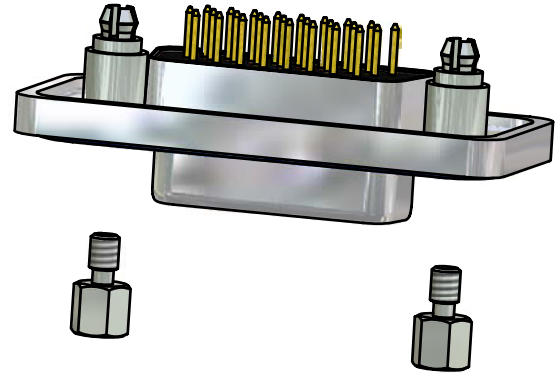
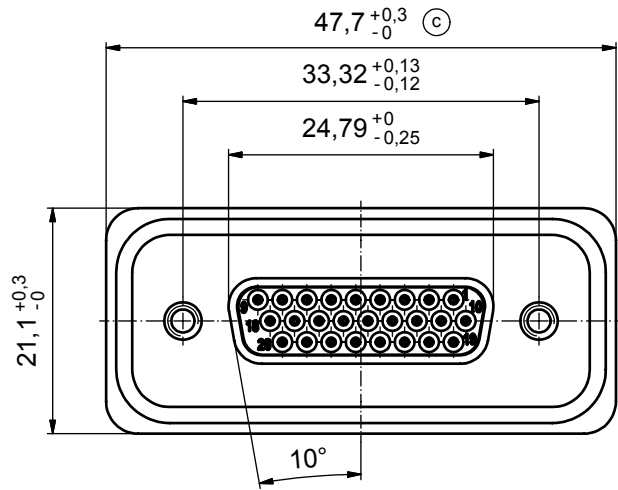
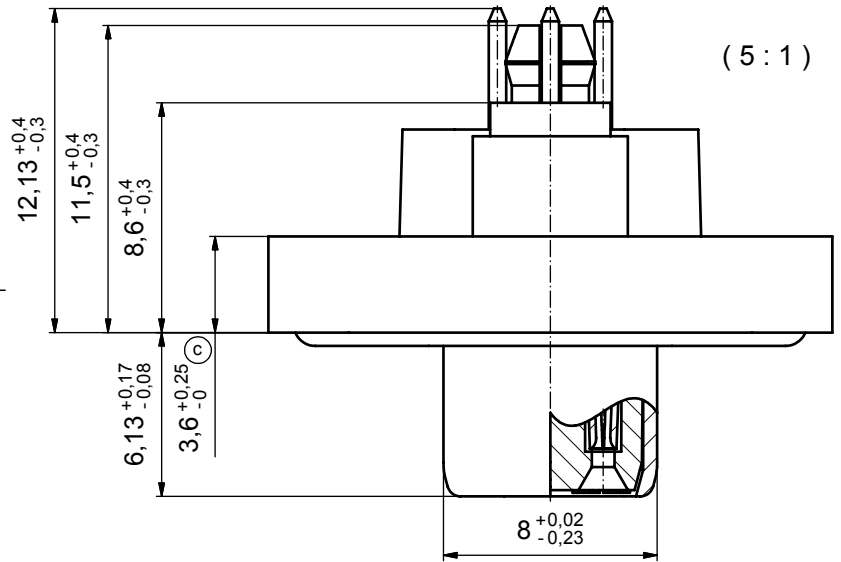

AT ALL TIMES WATER RESISTANT CONNECTORS NOT IN USE SHOULD BE COVERED WITH A CONEC WATER RESISTANT CAP OR WATER TIGHT HOOD.



APPROVAL # FREIGABE # DEBLOCAGE # AUTORIZACION # APPROVAL	
CUSTOMER APPROVAL DATE:	
NAME:	TITLE:
COMPANY NAME:	
APPROVAL # FREIGABE # DEBLOCAGE # AUTORIZACION # APPROVAL	

THIS DRAWING MAY NOT BE COPIED OR REPRODUCED IN ANY WAY, AND MAY NOT BE PASSED ON TO A THIRD PARTY WITHOUT WRITTEN PERMISSION. OWNERSHIP AND COPYRIGHT OF CONEC GmbH			
DO NOT ALTER CAD DRAWING BY HAND			
5 x c	Ä 3435	25.09.09	HS
3 x b	Ä 3129	26.09.08	HS
a	Origin		
rev.	description	date	name

tolerance	dim. in mm
date	name
drawn	09.09.08 Schmidt
appd.	15.09.08 Fischer
norm	
d-old	

scale:	2:1 (5:1)
material:	see notes
title:	
D-SUB FEMALE HD	
26pos. SOLDER PIN STRAIGHT	
with rear spacer clip and hexlocking screw	
dwg no:	Inventor 10
	DIN-A3
	sh: 1
part no:	15-00054 (see note 8) (b)



P.C.B. HOLE DRILLINGS

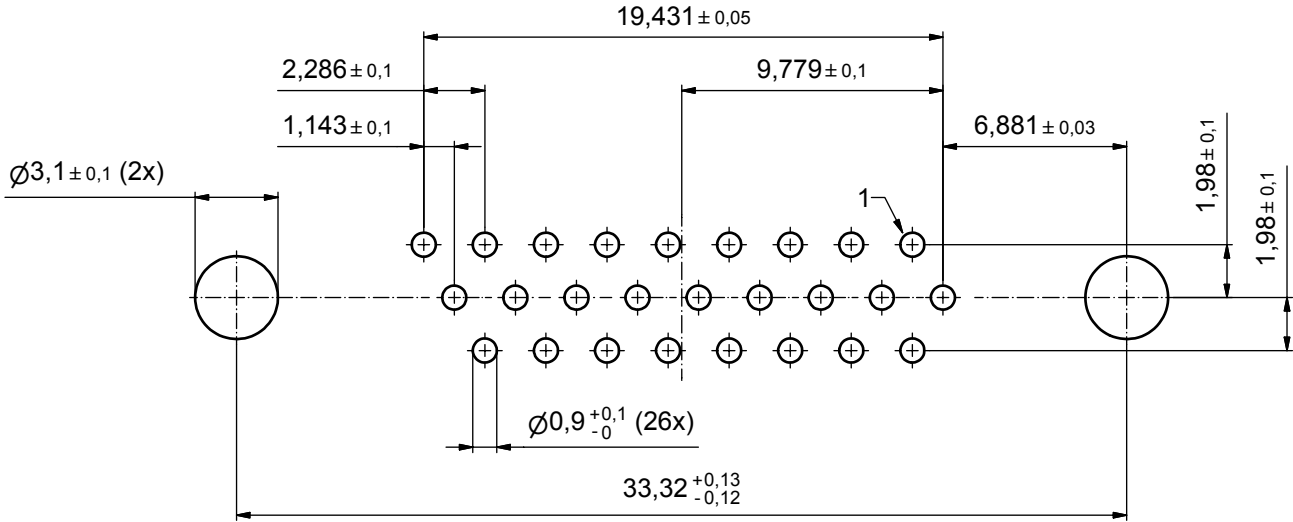

RECOMMENDED PANEL CUT-OUT (b)

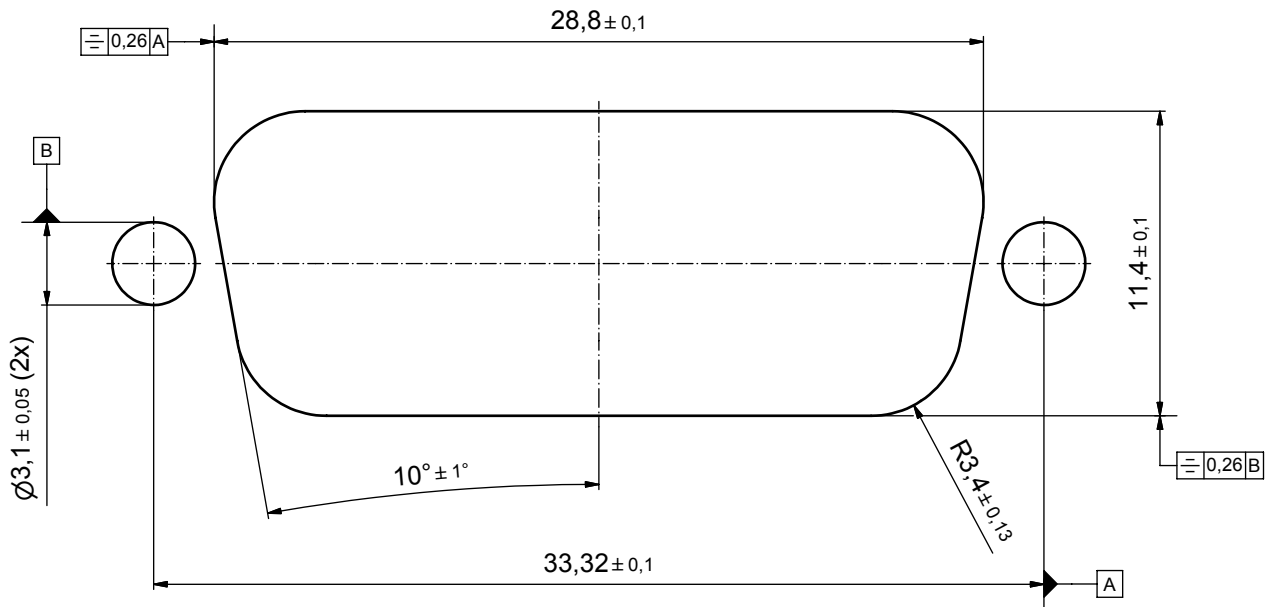

APPROVAL # FREIGABE # DEBLOCAGE # AUTORIZACION # APPROVAL	
CUSTOMER APPROVAL DATE:	
NAME:	TITLE:
COMPANY NAME:	
APPROVAL # FREIGABE # DEBLOCAGE # AUTORIZACION # APPROVAL	

THIS DRAWING MAY NOT BE COPIED OR REPRODUCED IN ANY WAY, AND MAY NOT BE PASSED ON TO A THIRD PARTY WITHOUT WRITTEN PERMISSION. OWNERSHIP AND COPYRIGHT OF CONEC GmbH				tolerance		dim. in mm	scale: 5:1	
DO NOT ALTER CAD DRAWING BY HAND				date			material: see sheet 1	
1 x b	A 3129	26.09.08	HS	drawn	09.09.08	Schmidt	title: P.C.B. HOLE DRILLINGS PANEL CUT-OUT D-SUB Female 26pos. HD Solder pin straight	
a	Origin			appd.	15.09.08	Fischer		
rev.	description	date	name	norm				
				d-old			dwg no:	Inventor 10
				CONEC			15K1A267	
							part no: see sheet 1	
						DIN-A3		
						sh: 2		

dwg no:		Inventor 10	DIN-A3
part no:		see sheet 1	sh: 2