

spec ref	-	dr	Andrew Yong	2010/10/21	projection	MM / INCH	size	A3	scale	10:1	
tolerance std	ISO 406 ISO 1101	eng	Yuan-Yuan Bao	2022/03/08			ecn no	ELX-N-44066-1			
surface	linear	chr	-	-			rel level	Released			
ISO 1302	angular	appr	Tim Yao	2022/03/09	product family	LPVCC	dwg no	10065490		rev	H
		Amphenol FCI			LOW PROFILE VCC 4.5 T.E. SMT ASSY WITH LOCATION FEATURES		cat. no. -		Product - Customer Drw		sheet 1 of 3

PRODUCT NO	POSITIONS	DIM. A	DIM. B	DIM. C
10065490-X06X	2 X 3	4.00 / .158	5.92 / .233	2.00 / .079
-X08X	2 X 4	6.00 / .236	7.92 / .312	4.00 / .158
-X10X	2 X 5	8.00 / .315	9.92 / .391	6.00 / .236
-X12X	2 X 6	10.00 / .394	11.92 / .469	8.00 / .315
-X14X	2 X 7	12.00 / .472	13.92 / .548	10.00 / .394
-X16X	2 X 8	14.00 / .551	15.92 / .627	12.00 / .472
-X18X	2 X 9	16.00 / .630	17.92 / .706	14.00 / .551
-X20X	2 X 10	18.00 / .709	19.92 / .784	16.00 / .630
-X22X	2 X 11	20.00 / .787	21.92 / .863	18.00 / .709
-X24X	2 X 12	22.00 / .866	23.92 / .942	20.00 / .787
-X26X	2 X 13	24.00 / .945	25.92 / 1.020	22.00 / .866
-X28X	2 X 14	26.00 / 1.024	27.92 / 1.099	24.00 / .945
-X30X	2 X 15	28.00 / 1.102	29.92 / 1.178	26.00 / 1.024
-X32X	2 X 16	30.00 / 1.181	31.92 / 1.257	28.00 / 1.102
-X34X	2 X 17	32.00 / 1.260	33.92 / 1.335	30.00 / 1.181
-X36X	2 X 18	34.00 / 1.339	35.92 / 1.414	32.00 / 1.260
-X38X	2 X 19	36.00 / 1.417	37.92 / 1.493	34.00 / 1.339
-X40X	2 X 20	38.00 / 1.496	39.92 / 1.572	36.00 / 1.417
-X42X	2 X 21	40.00 / 1.575	41.92 / 1.650	38.00 / 1.496
-X44X	2 X 22	42.00 / 1.654	43.92 / 1.729	40.00 / 1.575
-X46X	2 X 23	44.00 / 1.732	45.92 / 1.808	42.00 / 1.654
-X48X	2 X 24	46.00 / 1.811	47.92 / 1.887	44.00 / 1.732
-X50X	2 X 25	48.00 / 1.890	49.92 / 1.965	46.00 / 1.811

PLATING OPTIONS OVER CONTACT AREA
-0XXX = 0.05um/2u" Au
-1XXX = 0.76um/30u" Au
-3XXX = 0.38um/15u" Au
-4XXX = 0.76um/30u" GXT
-5XXX = 0.38um/15u" GXT
-6XXX = 2.54um/100u" MATTE TIN

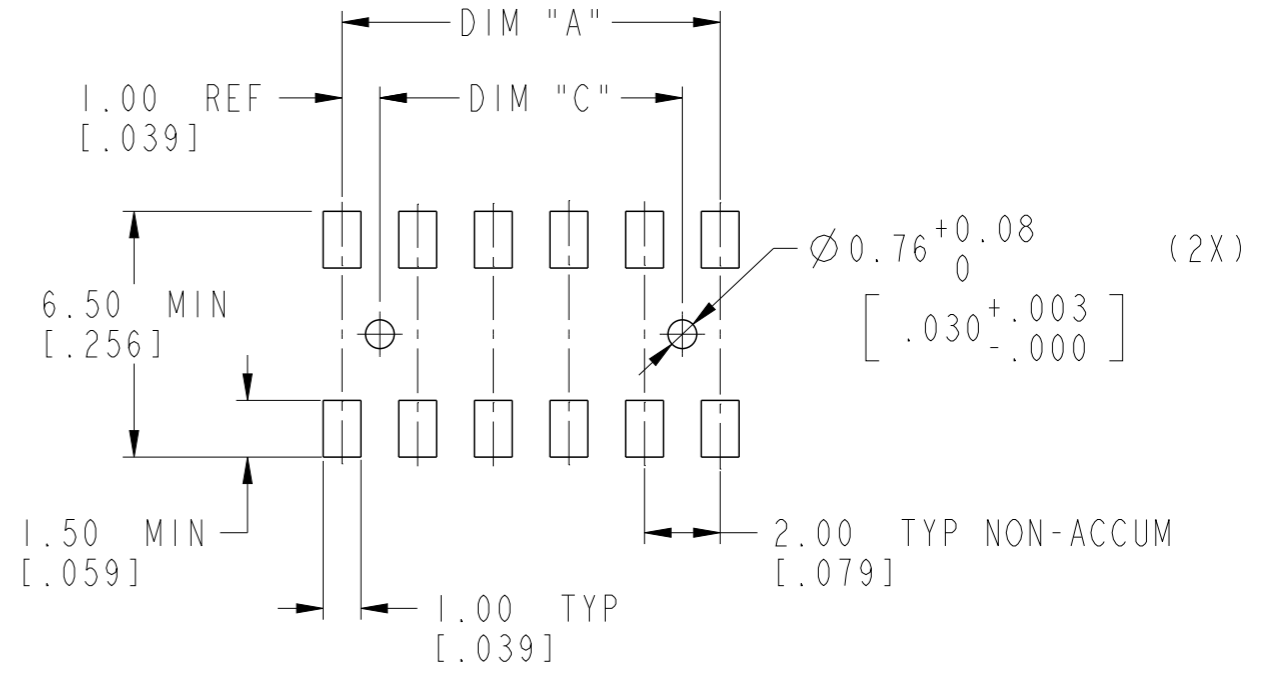

RECOMMENDED PAD LAYOUT

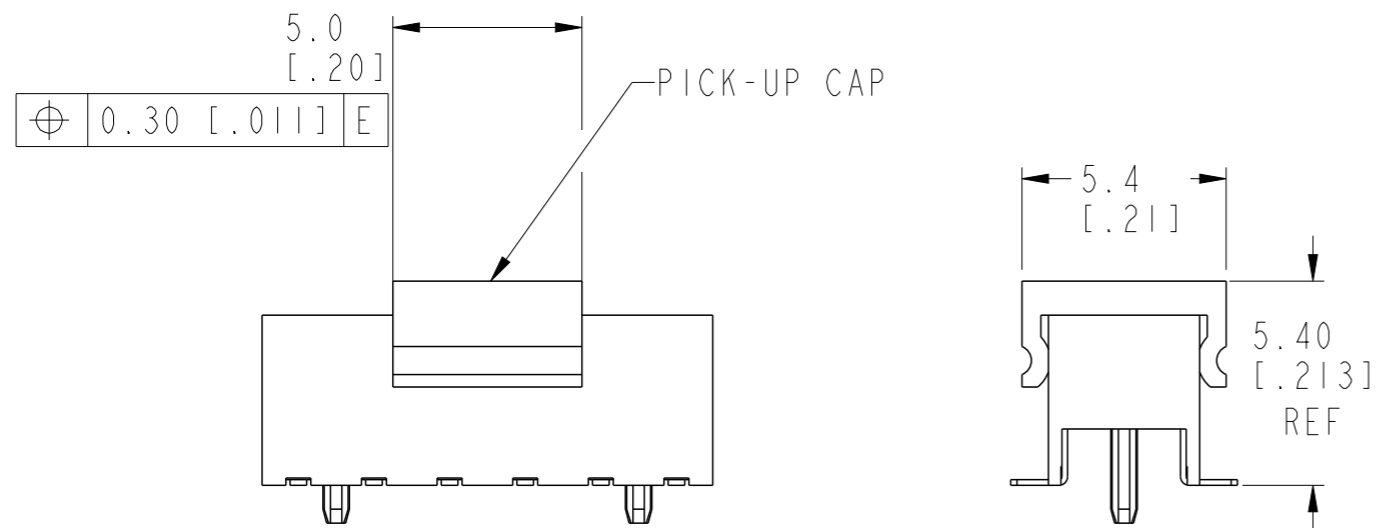

FIG. 1
NOTE 7(b)
SCALE 5:1

dr	Andrew Yong	2010/10/21	projection	MM / INCH	size	A3	scale	10:1
eng	Yuan-Yuan Bao	2022/03/08			ecn no ELX-N-44066-1			
chr	-	-			rel level Released			
appr	Tim Yao	2022/03/09	product family LPVCC		rel level Released			
Amphenol FCI			LOW PROFILE VCC 4.5 T.E. SMT ASSY WITH LOCATION FEATURES			dwg no 10065490		rev H
cat. no.			-			Product - Customer Drw		sheet 2 of 3

© 2020 Amphenol Corporation

NOTES:

- 1. HOUSING MATERIAL : HIGH TEMP PLASTIC.
- 2. TERMINAL MATERIAL : COPPER ALLOY.
- 3. TERMINAL RETENTION 0.5Kg/1.1 Lbs.
- ④ "V" CUT OPTIONAL - MANUFACTURING PROCESS OPTION.
- 5. SOLDER TAILS ARE TIN/LEAD PLATED FOR P/N:10065490-XXXX(EXCEPT -4XXX AND -5XXX).
- ⑥ SOLDER TAILS ARE 100% MATTE TIN PLATED FOR P/N:10065490-XXXXLF.
- ⑦ PRODUCT DESCRIPTION CODE :

XXXXXXXX-X XX X TR X LF

LEAD FREE. SEE NOTES 6 & 12.
 BLANK: WITHOUT WATER PROOF BAG
 W: WITH WATER PROOF BAG
 TAPE & REEL PACKAGE SEE NOT 8
 BLANK: STD TYPE W/O MARK
 A: CUSTOMERIZED GOLD PLATING WITH MARK "A"
 TOTAL POSITIONS
 PLATING AT CONTACT AREA.
 BASE NUMBER

- 8. PACKAGING:
 (a) XXXXXXXX-XXXX --- STD PACKAGING IN TUBE.
 (b) XXXXXXXX-XXXXTR --- TAPE AND REEL PACKAGING WITH PICK-UP CAP (FIG. 1).
- ⑨ CO-PLANARITY
 FROM POSITION -X04X THRU -X38X: 0.10/.004
 -X04X THRU -X50X: 0.12/.005

10. THE HOUSING WILL WITHSTAND EXPOSURE TO 255°C PEAK TEMPERATURE FOR 10 SECONDS IN A CONVECTION, INFRA-RED OR VAPOR PHASE REFLOW OVEN.

- 11. THE HOUSING WILL WITHSTAND EXPOSURE TO 260°C PEAK TEMPERATURE FOR 10 SECONDS IN A WAVE SOLDER APPLICATION WITH A 1.57MM MINIMUM THICK CIRCUIT BOARD.
- ⑫ THIS PRODUCT MEETS EUROPEAN UNION DIRECTIVES AND OTHER COUNTRY REGULATIONS AS DESCRIBED IN GS-22-008.

10065490-XXXAXXLF TOP VIEW SEE NOTE 7

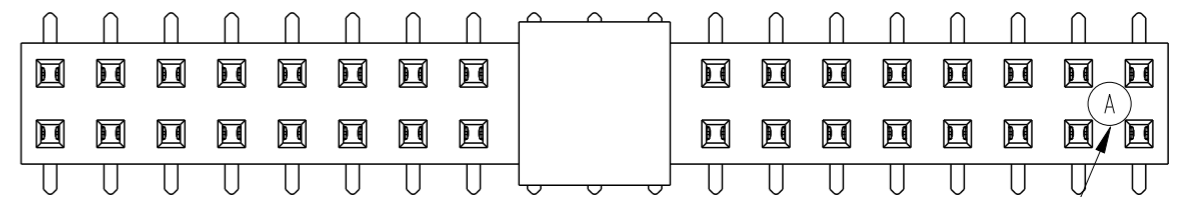

WITH MARK "A"

Amphenol FCI

© 2020 Amphenol Corporation

dr	Andrew Yong	2010/10/21	projection 	MM / INCH	size	A3	scale	1:1
eng	Yuan-Yuan Bao	2022/03/08			ecn no	ELX-N-44066-1		
chr	-	-			rel level	Released		
appr	Tim Yao	2022/03/09			product family	LPVCC		
Amphenol FCI		LOW PROFILE VCC 4.5 T.E. SMT ASSY WITH LOCATION FEATURES			dwg no 10065490	rev H		
cat. no.		-			Product - Customer Drw		sheet 3 of 3	