

# R58A Series Registration Mark Sensors



## Datasheet

Registration Mark Sensors with Single Color LED and Potentiometer Adjustment of Switching Threshold





- Fast 10 kHz switching frequency; 15  $\mu$ s repeatability
- Rugged zinc alloy die-cast housing with high quality acrylic lens suitable for use around food processing applications: Sensor rated IEC IP67
- Fixed-convergent sensing at 10 mm  $\pm$  3 mm (0.39 in  $\pm$  0.12 in)
- Rectangular 1.2 mm  $\times$  3.8 mm (0.05 in  $\times$  0.15 in) sensing image at 10 mm (0.39 in) from the face of the lens
- Easy selection of Light/ Dark Operate (LO/ DO) by selection switch
- Red or green LEDs available, depending on model
- Parallel or perpendicular sensing image, depending on model
- 20 millisecond OFF-delay by model



### WARNING: Not To Be Used for Personnel Protection

Never use this device as a sensing device for personnel **protection**. Doing so could lead to serious injury or death. This device does not include the self-checking redundant circuitry necessary to allow its use in personnel safety applications. A sensor failure or malfunction can cause either an energized or de-energized sensor output condition.

## Models

Models <sup>1</sup>	Output & Supply Voltage	Focus Distance	Sensing Image Orientation	Emitter Color	OFF-Delay	
R58ACG1	Bipolar NPN/ PNP 10 V dc to 30 V dc	10 mm (0.39 in)	Parallel to sensor length 	Green	0	
R58ACG1D					20 ms	
R58ACR1			Perpendicular to sensor length 	Red	0	
R58ACR1D					20 ms	
R58ACG2			Green	Perpendicular to sensor length		0
R58ACG2D						20 ms
R58ACR2			Red	Perpendicular to sensor length		0
R58ACR2D						20 ms

<sup>1</sup> Integral 2 m (6.5 ft) unterminated cable models are listed.

- To order the 9 m (30 ft) PVC cable model, add the suffix "W/30" to the cabled model number. For example, R58ACG1 W/30.
- To order the 150 mm (6 in) PVC cable model, add the suffix "Q" to the model number. For example, R58ACG1Q.
- To order the 4-pin M12/ Euro-style integral quick disconnect model, add the suffix "Q8" to the model number. For example, R58ACG1Q8.



## Overview

F58A sensors offer high-performance, cost-effective registration mark sensing featuring a single emitter color and simplified sensor setup and adjustment.

The switching threshold is adjusted with a potentiometer, and two green LEDs assist with setting the optimal threshold. Output status information is provided by an amber output LED. Light Operate or Dark Operate is also easily selectable via the LO/DO selection switch.

The fast 10 kHz switching frequency and 15 microsecond repeatability ensure reliability in high-speed operations. Models are available with a parallel or perpendicular sensing image, as well as a 20 millisecond OFF-delay to solve a variety of applications. The rugged zinc alloy die-cast housing and high quality acrylic lens are designed to handle ambient electrical noise and vibration from presses and die cutting machinery.



1. Amber Output Indicator
2. Green Setup Indicators
3. Switching Threshold Potentiometer
4. LO/DO Selection Switch

Figure 1. Features

## Wiring Diagrams

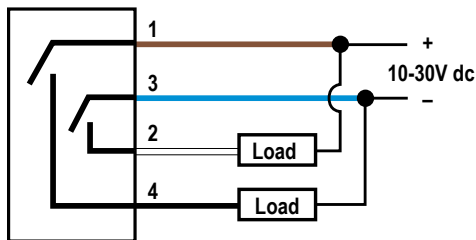

Wiring Key:

- 1 = Brown
- 2 = White
- 3 = Blue
- 4 = Black

## Set Up the Sensor

1. Align the light spot to the mark.



2. Turn the potentiometer in the direction shown by the green LED until it switches.



3. Align the light spot to the background.



4. Turn the potentiometer, and count turns, in the direction shown by green LED until it switches.



- Turn potentiometer back half the number of turns from step 4.



- Select Light Operate or Dark Operate.



## Specifications

### Supply Voltage and Current

10 V dc to 30 V dc (10% max. ripple within specified voltage range); 36 mA exclusive of load

### Supply Protection Circuitry

Protected against reverse polarity and transient voltages

### Output Configuration

Bipolar; one current sourcing (PNP) and one current sinking (NPN)

### Output Rating

150 mA max. (each output)

**Off-state** leakage current: < 10 microamps

**NPN saturation:** < 200 mV at 10 mA and < 1.0 V at 150 mA

**PNP saturation:** < 1 V at 10 mA and < 2.0 V at 150 mA

### Output Protection Circuitry

Protected against output short-circuit, continuous overload, and false pulse on power-up

### Output Response Time

50 microseconds: 100 millisecond delay on power-up (outputs do not conduct)

### Repeatability

15 microseconds

### Sensing Image

Rectangular: 1.2 mm x 3.8 mm (0.05 in x 0.15 in) at 10 mm (0.39 in) from face of lens; Image oriented either parallel or perpendicular to sensor length, by model (see [Models](#) on page 1).

### Adjustments

Light/Dark Operate (LO/DO) select switch, and 15-turn switchpoint adjustment potentiometer

### Indicators

1 Amber: Output active

2 Green: Switchpoint threshold adjustment indicators

### Construction

Housing: Zinc alloy die-cast housing with black painted finish and o-ring sealed lens port cap

Lens: Acrylic

Lens port cap and lens holder: ABS

**Sensitivity** and LO/DO adjusters: Acetal

QD: Anodized aluminum

### Environmental Rating

IEC IP67; NEMA 6

### Connections

PVC-jacketed 4-conductor 2 m (6.5 ft); 9 m (30 ft) attached cable; integral 4-pin Euro-style QD fitting; or 150 mm (6 in) with 4-pin Euro-style QD fitting. Mating QD cordsets are purchased separately.

### Operating Conditions

Temperature: -10 °C to +55 °C (+14 °F to +131 °F)

Storage Temperature -20 °C to +80 °C (-4 °F to +176 °F)

90% at +50 °C maximum relative humidity (non-condensing)

### Vibration and Shock

All models meet IEC 68-2-6 and IEC 68-2-27 testing criteria

### Application Notes

- Do not mount the sensor directly perpendicular to shiny surfaces; position it at approximately 15 degree angle in relation to the sensing target.
- Minimize web or product "flutter" whenever possible to maximize sensing reliability. Position sensor near a roller if possible.
- The lens may be installed in either of the two lens ports. The lens port cap must be installed on the unused port for reliable operation.

### Required Overcurrent Protection



**WARNING:** Electrical connections must be made by qualified personnel in accordance with local and national electrical codes and regulations.

Overcurrent protection is required to be provided by end product application per the supplied table.

Overcurrent protection may be provided with external fusing or via Current Limiting, Class 2 Power Supply.

Supply wiring leads < 24 AWG shall not be spliced.

For additional product support, go to [www.bannerengineering.com](http://www.bannerengineering.com).

Supply Wiring (AWG)	Required Overcurrent Protection (Amps)
20	5.0
22	3.0
24	2.0
26	1.0
28	0.8
30	0.5

### Certifications



## Dimensions

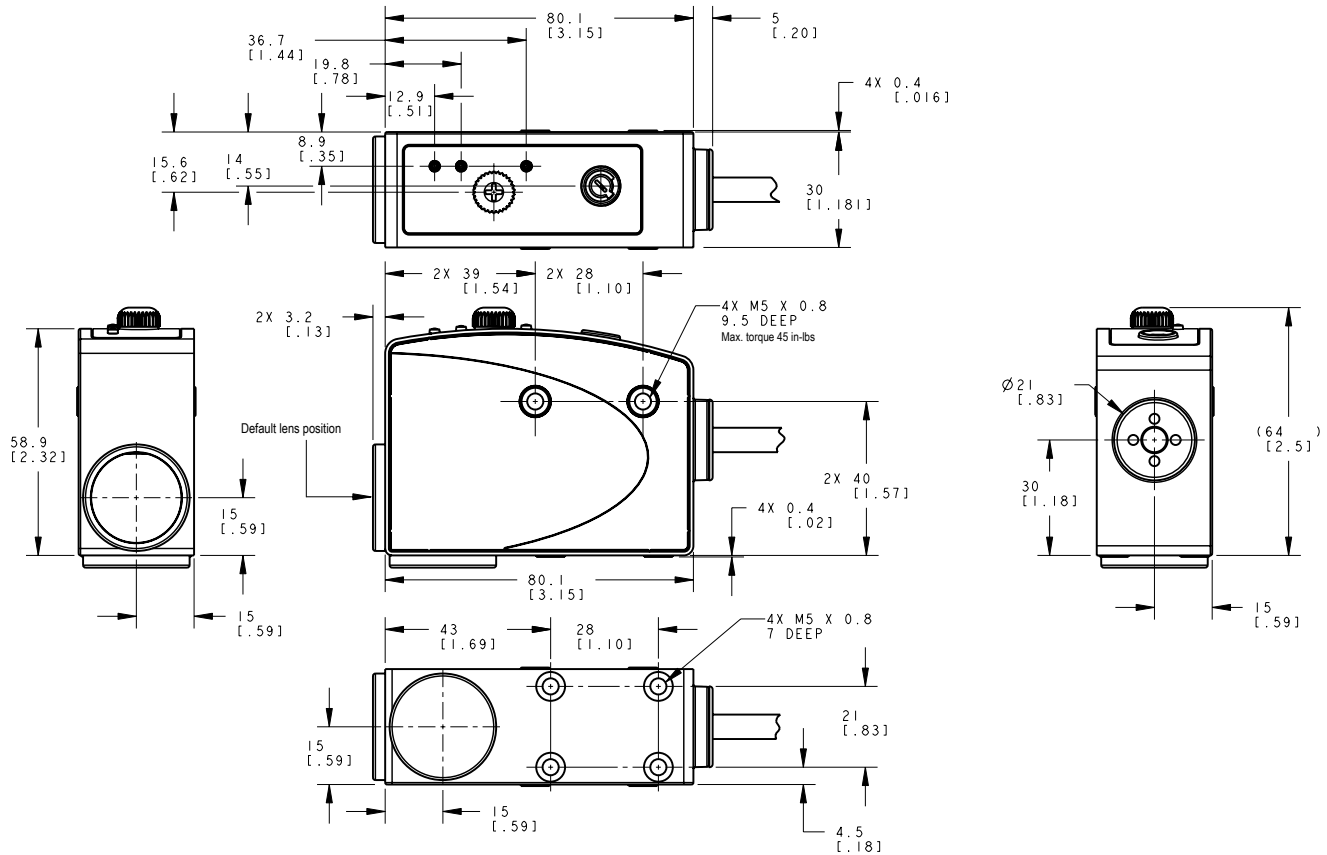

## Accessories

### Quick-Disconnect (QD) Cordsets

4-Pin Threaded M12/ Euro-Style Cordsets				
Model	Length	Style	Dimensions	Pinout (Female)
MQDC-406	1.83 m (6 ft)	Straight		<p>1 = Brown 2 = White 3 = Blue 4 = Black</p>
MQDC-415	4.57 m (15 ft)			
MQDC-430	9.14 m (30 ft)			
MQDC-450	15.2 m (50 ft)			
MQDC-406FA	1.83 m (6 ft)	Right-Angle		
MQDC-415FA	4.57 m (15 ft)			
MQDC-430FA	9.14 m (30 ft)			
MQDC-450FA	15.2 m (50 ft)			

## Mounting Brackets

### SMB55A

- 15° offset bracket
- 12-gauge stainless steel



### SMB55F

- Flat-mount bracket
- 12-gauge stainless steel



### SMB55RA

- Right-angle bracket
- 12-gauge stainless steel



### SMB55S

- 15° offset bracket
- 12-gauge stainless steel



## Replacement Lens

### UC-F55

- Replacement lens for F58A, F58B, and F58E



## Banner Engineering Corp. Limited Warranty

Banner Engineering Corp. warrants its products to be free from defects in material and workmanship for one year following the date of shipment. Banner Engineering Corp. will repair or replace, free of charge, any product of its manufacture which, at the time it is returned to the factory, is found to have been defective during the warranty period. This warranty does not cover damage or liability for misuse, abuse, or the improper application or installation of the Banner product.

**THIS LIMITED WARRANTY IS EXCLUSIVE AND IN LIEU OF ALL OTHER WARRANTIES WHETHER EXPRESS OR IMPLIED (INCLUDING, WITHOUT LIMITATION, ANY WARRANTY OF MERCHANTABILITY OR FITNESS FOR A PARTICULAR PURPOSE), AND WHETHER ARISING UNDER COURSE OF PERFORMANCE, COURSE OF DEALING OR TRADE USAGE.**

This Warranty is exclusive and limited to repair or, at the discretion of Banner Engineering Corp., replacement. IN NO EVENT SHALL BANNER ENGINEERING CORP. BE LIABLE TO BUYER OR ANY OTHER PERSON OR ENTITY FOR ANY EXTRA COSTS, EXPENSES, LOSSES, LOSS OF PROFITS, OR ANY INCIDENTAL, CONSEQUENTIAL OR SPECIAL DAMAGES RESULTING FROM ANY PRODUCT DEFECT OR FROM THE USE OR INABILITY TO USE THE PRODUCT, WHETHER ARISING IN CONTRACT OR WARRANTY, STATUTE, TORT, STRICT LIABILITY, NEGLIGENCE, OR OTHERWISE.

Banner Engineering Corp. reserves the right to change, modify or improve the design of the product without assuming any obligations or liabilities relating to any product previously manufactured by Banner Engineering Corp. Any misuse, abuse, or improper application or installation of this product or use of the product for personal protection applications when the product is identified as not intended for such purposes will void the product warranty. Any modifications to this product without prior express approval by Banner Engineering Corp will void the product warranties. All specifications published in this document are subject to change; Banner reserves the right to modify product specifications or update documentation at any time. Specifications and product information in English supersede that which is provided in any other language. For the most recent version of any documentation, refer to:

[www.bannerengineering.com](http://www.bannerengineering.com).