

# Impulse / Latching Relays

## R50 Series



### Features

- Magnetic Latching
- Solder/Plug-In
- .187" (4.75mm) Quick Connect Terminals
- SPDT or DPDT
- Dual Coil Version - "C" Suffix
- Non-Mechanical Latches



D50

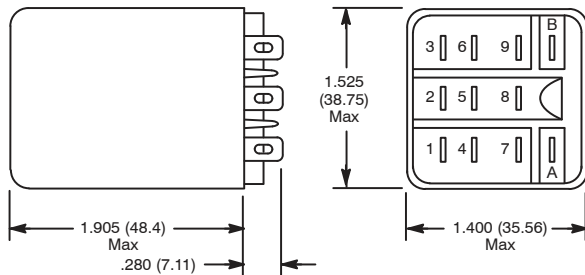

AC OPERATED						
NTE Type No.	Nom. Volt.	Contact Arr.	Coil Res. Latch/Unlatch Ohms (Typ)	Nom. Power	Max. Contact Cur. @ 28VDC or 120VAC	Diag No.
R50-5A10-120	120VAC	SPDT	2090/17430	1.7VA	10A	D50
R50-11A10-120	120VAC	DPDT	2090/17430	1.7VA	10A	D50
DC OPERATED						
R50-5D10-24	24VDC	SPDT	472/1152	1.2W	10A	D50
R50-11D10-12	12VDC	DPDT	120/275	1.2W	10A	D50
R50-11D10-12C	12VDC	DPDT	88/275	1.2W	10A	D50
R50-11D10-24	24VDC	DPDT	472/1152	1.2W	10A	D50
R50-11D10-24C	24VDC	DPDT	330/1070	1.2W	10A	D50

ACCESSORIES		
MOUNTING STYLES	DESCRIPTION	NTE TYPE NO.
SURFACE MOUNT SCREW TERMINALS	11-PIN BLADE	R95-105
PANEL MOUNT SOLDER TERM	11-PIN BLADE	R95-116
PANEL MOUNT QUICK CONNECT	11-PIN BLADE	R95-124
DIN RAIL MOUNT	11-PIN BLADE	R95-115
PC MOUNT	11-PIN BLADE	R95-123

## AC and DC Magnetic Latching Industrial Relay for Industrial Controls, Instrumentation.

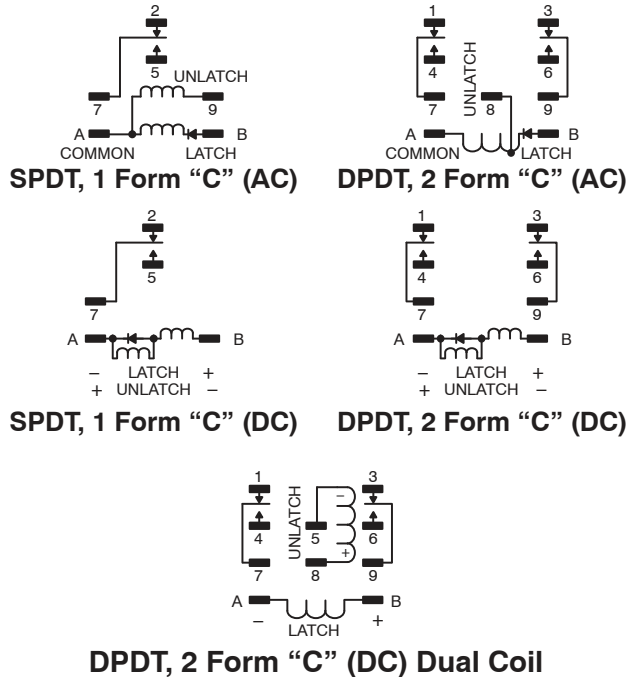

## Operational Information

Magnetic latching is achieved by a specially designed magnetic core that makes it possible to maintain a substantial magnetic force of attraction after termination of the electrical pulse that energizes the core. There are no mechanical latches associated with this relay, nor permanent magnets. To restore the relay to its unoperated position, a short pulse of opposite polarity and lower magnitude than the operate pulse is applied to the coil or a second concentric wound coil.

## Electrical Specifications

### Contact

**Rating:** 10 Amp @ 28VDC/120/240 VAC  
1/3HP @ 120VAC,  
1/2HP @ 240/480/600VAC

**Material:** 3/16" Silver Cadmium Oxide

### Coil

**Coil Voltages:** See Chart

**Pick-up Voltages:** 85% of nominal Coil Vltg. (AC)  
75% of nominal Coil Vltg. (DC)

**Duty Cycle:** Continuous duty operation at 25% overvoltage

**Resistance:** See Chart

### Operational Characteristics

**Timing Values:**

**Operate Time:** 15ms Nominal, 20ms Max  
**Release Time:** 6ms Nominal, 10ms Max

### Insulation Characteristics

**Dielectric Breakdown:** >750VAC RMS across open contacts  
>2500VAC RMS all other mutually insulated elements

### Environmental Characteristics

**Operating:** -45°C to +60°C

### Life

**Mechanical:** 10 million operations

### Weight

**Std:** 3.0 oz (84 grams) approx