

REVISION

J

NOTES:

1. FILL ROWS 3, 4, 7, 8 ONLY, VITA 57 CONNECTOR.
2. NOTE DELETED.
3. Ⓢ REPRESENTS A CRITICAL DIMENSION.
4. MINIMUM PUSHOUT FORCE: 0.50 LBS.
5. DIMENSION C8 MUST BE MEASURED IN THE FOUR OUTSIDE CORNERS USING INSPECTION FIXTURE AT-1817-836-2, USE CO-AU-WI-2003-M FOR PROCESS.
6. MAXIMUM ROW TO ROW VARIATION .003[0.08], MEASURED FIRST & LAST POSITIONS ONLY, ALL ROWS. Ⓢ
7. ATTACH LABEL "SEAX-0001" TO EACH TAPE & REEL PACKAGE.
8. PARTS TO BE PACKAGED IN TAPE & REEL.

J	TW	J Zahn
12/7/2016	ECN-290810	
NOTES: DEL NOTE 2 (FILL ROWS.) & ADD TO NOTE 1		

DATE: _____

COMPANY: _____

CUSTOMER SIGNATURE: _____

PRINTED NAME: _____

PHONE NO: _____

FAX NO: _____

ACCEPTANCE OF DRAWING: ACCEPTED WITH DEVIATIONS LISTED

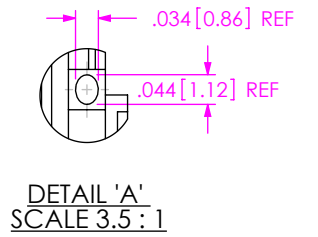
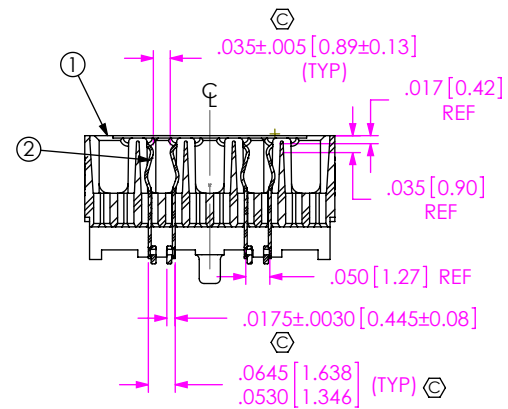
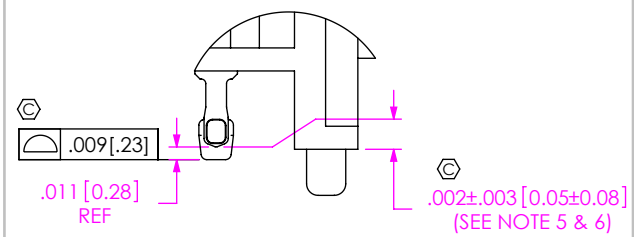
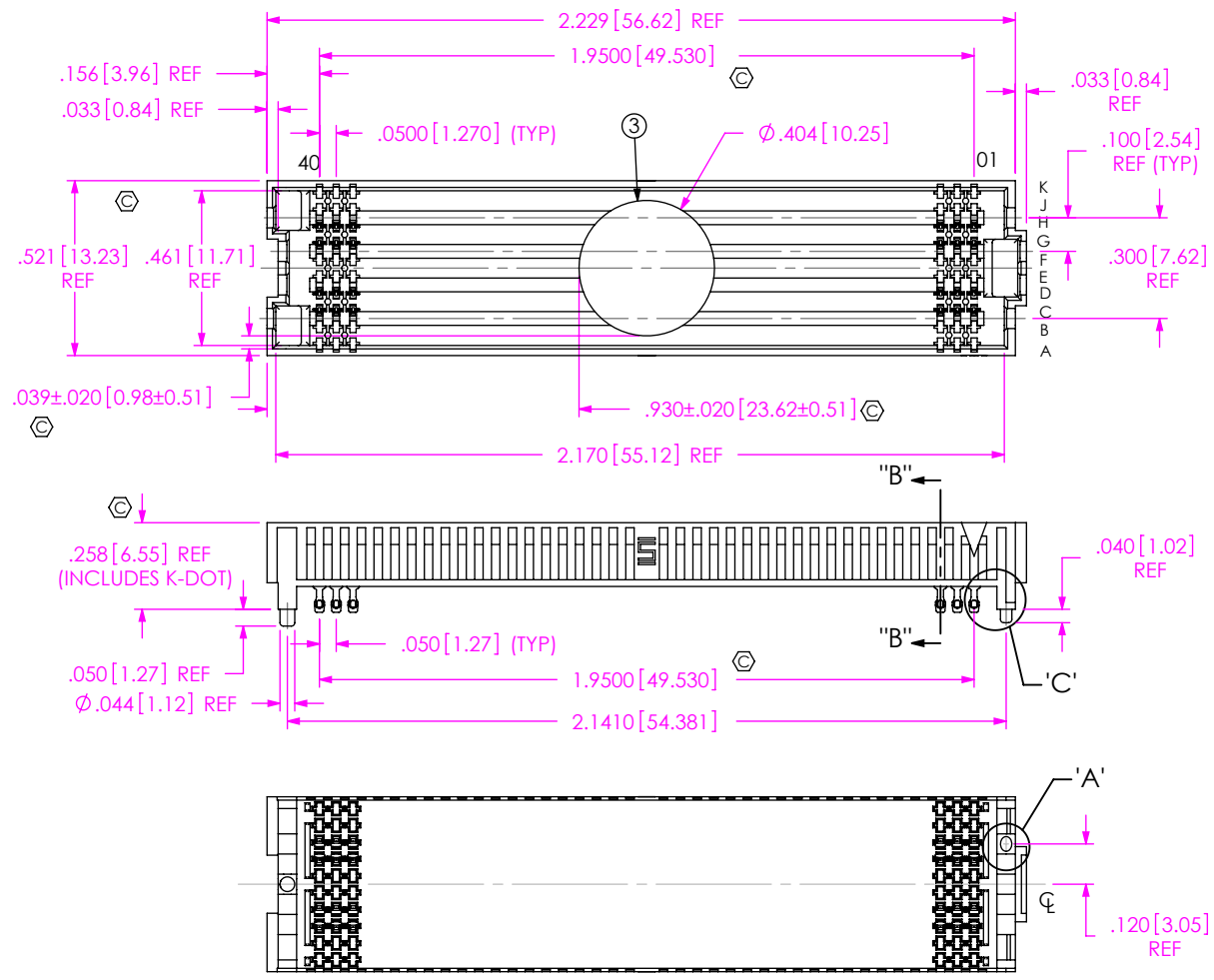

ITEM NO.	PART NUMBER	QUANTITY	MATERIAL
1	SEAF-40-06.5-10-A	1.0000	LCP UL 94 V0, COLOR: BLACK
2	NEW-SUB-C-209-06.5-S-1	160.00	COPPER ALLOY / LEADED SOLDER
3	CT-SEAF028MS	1.0000	CONDUCTIVE POLYMER
4	K-DOT-.404-.500-.005	1.0000	POLYIMIDE FILM

UNLESS OTHERWISE SPECIFIED, DIMENSIONS ARE IN INCHES. TOLERANCES ARE:

DECIMALS	ANGLES
.XX: ±.01 [.3]	2°
.XXX: ±.005 [.13]	
.XXXX: ±.0020 [.051]	

PROPRIETARY NOTE
THIS DOCUMENT CONTAINS INFORMATION CONFIDENTIAL AND PROPRIETARY TO SAMTEC, INC. AND SHALL NOT BE REPRODUCED OR TRANSFERRED TO OTHER DOCUMENTS OR DISCLOSED TO OTHERS OR USED FOR ANY PURPOSE OTHER THAN THAT WHICH IT WAS OBTAINED WITHOUT THE EXPRESSED WRITTEN CONSENT OF SAMTEC, INC.



520 PARK EAST BLVD., NEW ALBANY, IN 47150
PHONE: 812-944-6733 FAX: 812-948-5047
e-Mail: info@SAMTEC.com code 53322

DO NOT SCALE DRAWING SHEET SCALE: 1:7.51
PLATING: CONTACT AREA: .000030 GOLD OVER .000050 NICKEL
REMAINDER: .000200 REF TIN OVER .000050 NICKEL

DESCRIPTION: .050 PITCH SOCKET ARRAY ASSEMBLY

DWG. NO. ASP-127796-01

BY: B. PERRY 08/25/2006 SHEET 1 OF 4

NOTE:
STENCIL TO BE .0060[.152] THICK.

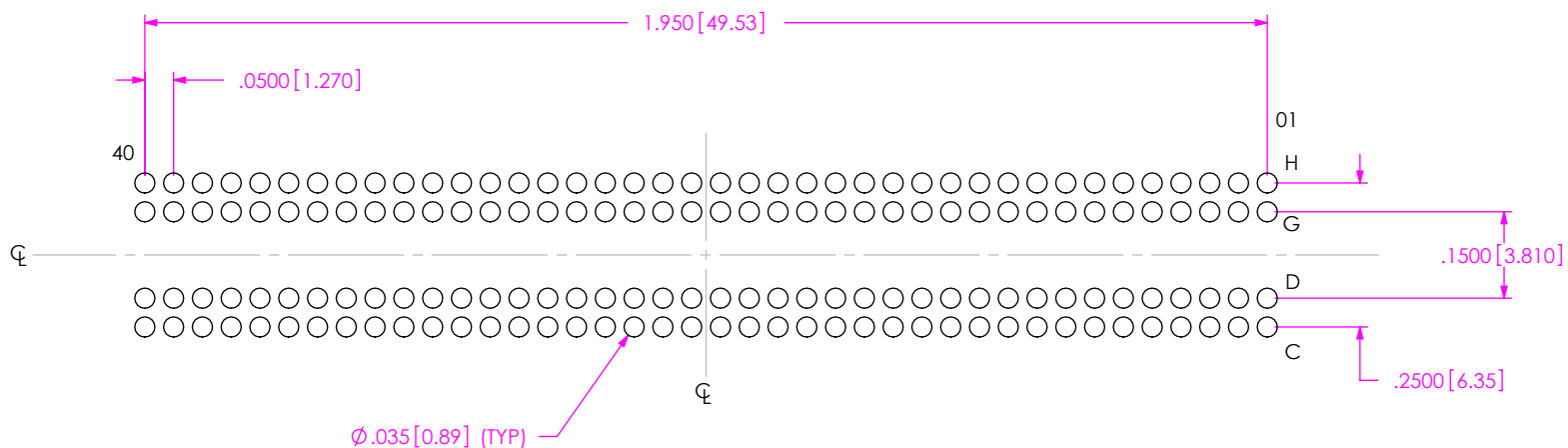

ALL DIMENSIONS SYMMETRIC ABOUT THE CENTERLINE

PROPRIETARY NOTE

THIS DOCUMENT CONTAINS INFORMATION CONFIDENTIAL AND PROPRIETARY TO SAMTEC, INC. AND SHALL NOT BE REPRODUCED OR TRANSFERRED TO OTHER DOCUMENTS OR DISCLOSED TO OTHERS OR USED FOR ANY PURPOSE OTHER THAN THAT WHICH IT WAS OBTAINED WITHOUT THE EXPRESSED WRITTEN CONSENT OF SAMTEC, INC.



520 PARK EAST BLVD., NEW ALBANY, IN 47150
PHONE: 812-944-6733 FAX: 812-948-5047
e-Mail info@SAMTEC.com code 55322

SHEET SCALE: 1:1

DESCRIPTION:
.050 PITCH SOCKET ARRAY ASSEMBLY

DWG. NO. ASP-127796-01

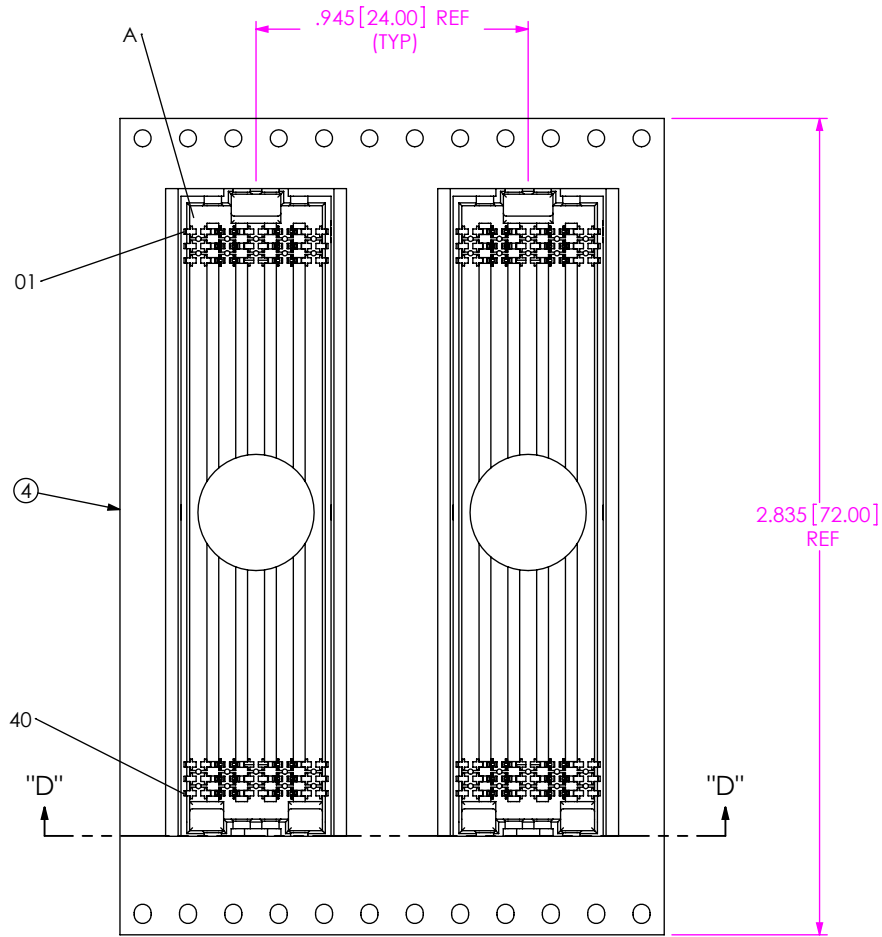

USER DIRECTION OF UN-REELING →
POCKET NOT DETAILED

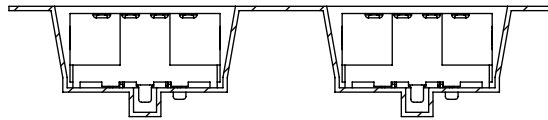

PROPRIETARY NOTE

THIS DOCUMENT CONTAINS INFORMATION CONFIDENTIAL AND PROPRIETARY TO SAMTEC, INC. AND SHALL NOT BE REPRODUCED OR TRANSFERRED TO OTHER DOCUMENTS OR DISCLOSED TO OTHERS OR USED FOR ANY PURPOSE OTHER THAN THAT WHICH IT WAS OBTAINED WITHOUT THE EXPRESSED WRITTEN CONSENT OF SAMTEC, INC.



520 PARK EAST BLVD., NEW ALBANY, IN 47150
PHONE: 812-944-6733 FAX: 812-948-5047
e-Mail info@SAMTEC.com code 55322

SHEET SCALE: 1.5:1

DESCRIPTION:
.050 PITCH SOCKET ARRAY ASSEMBLY

DWG. NO. ASP-127796-01