

THIS DRAWING IS UNPUBLISHED. RELEASED FOR PUBLICATION
 © COPYRIGHT - By - ALL RIGHTS RESERVED.

LOC	DIST	REVISIONS			
P	LTR	DESCRIPTION	DATE	DWN	APVD
AF	50	N	REVISED PER ECR-13-011489	06DEC2013	KH PD

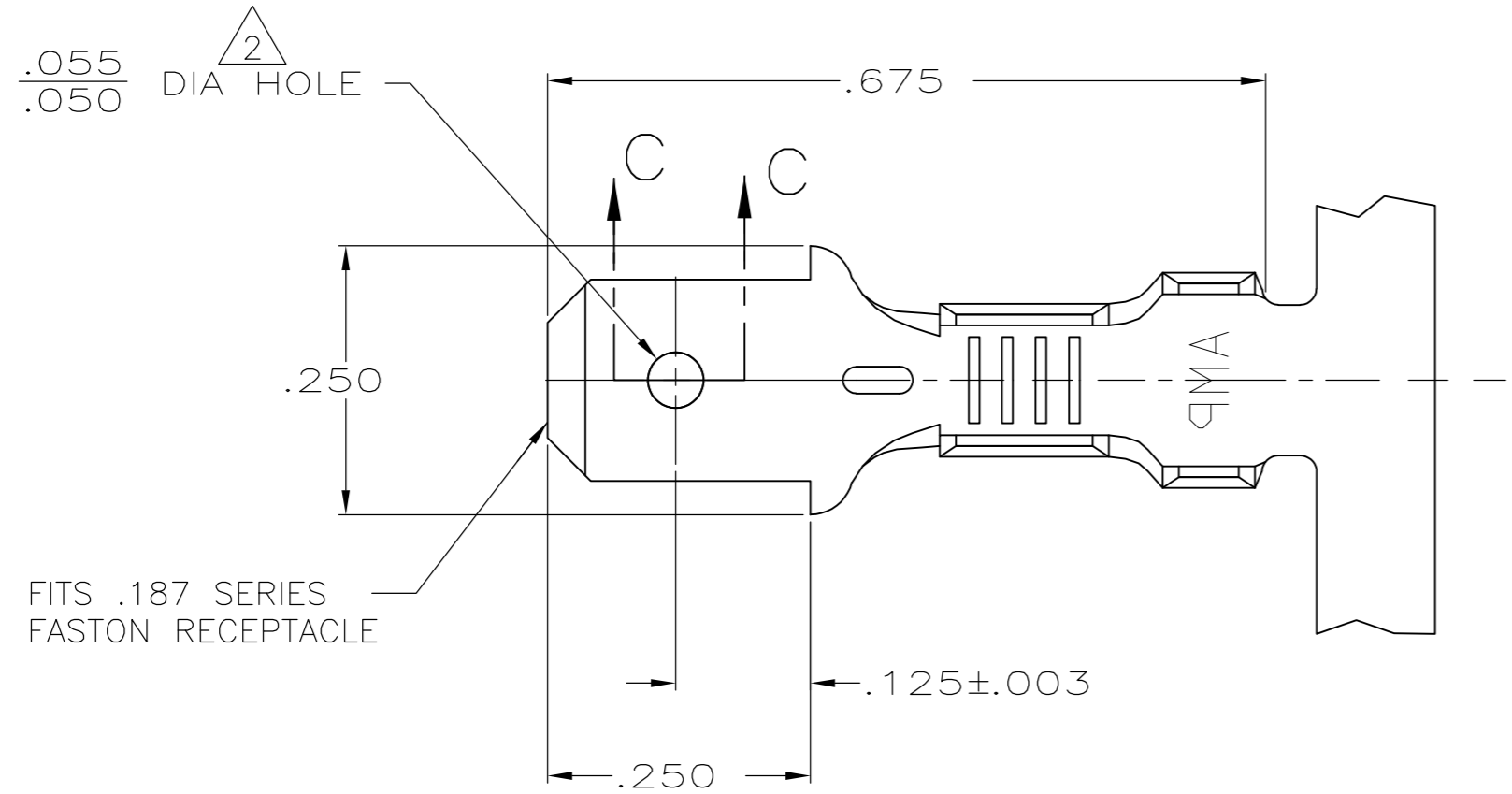

- 1 CONTINUOUS STRIP ON REEL.
- 2 NO BURRS PERMISSIBLE AT HOLE. .005 MAX RADIUS PERMISSIBLE ON TOP.

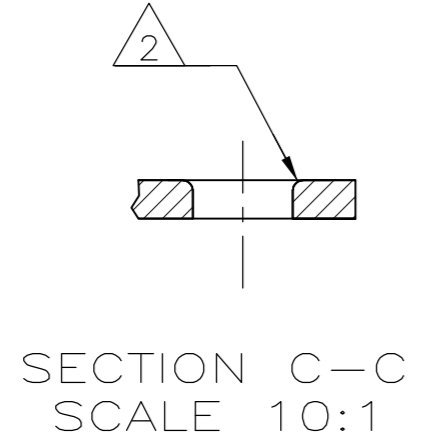
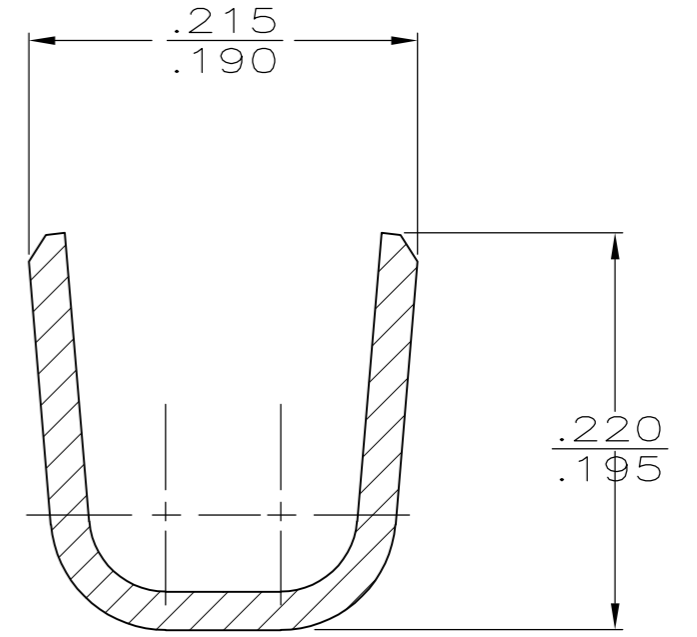
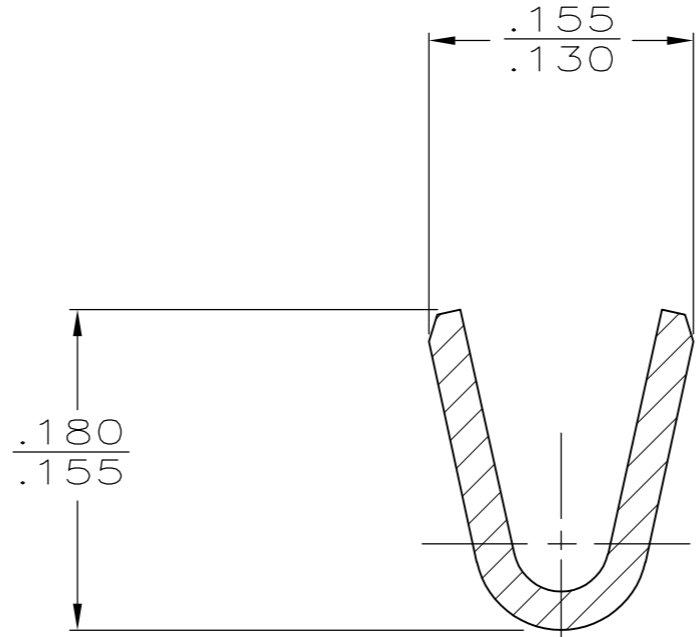
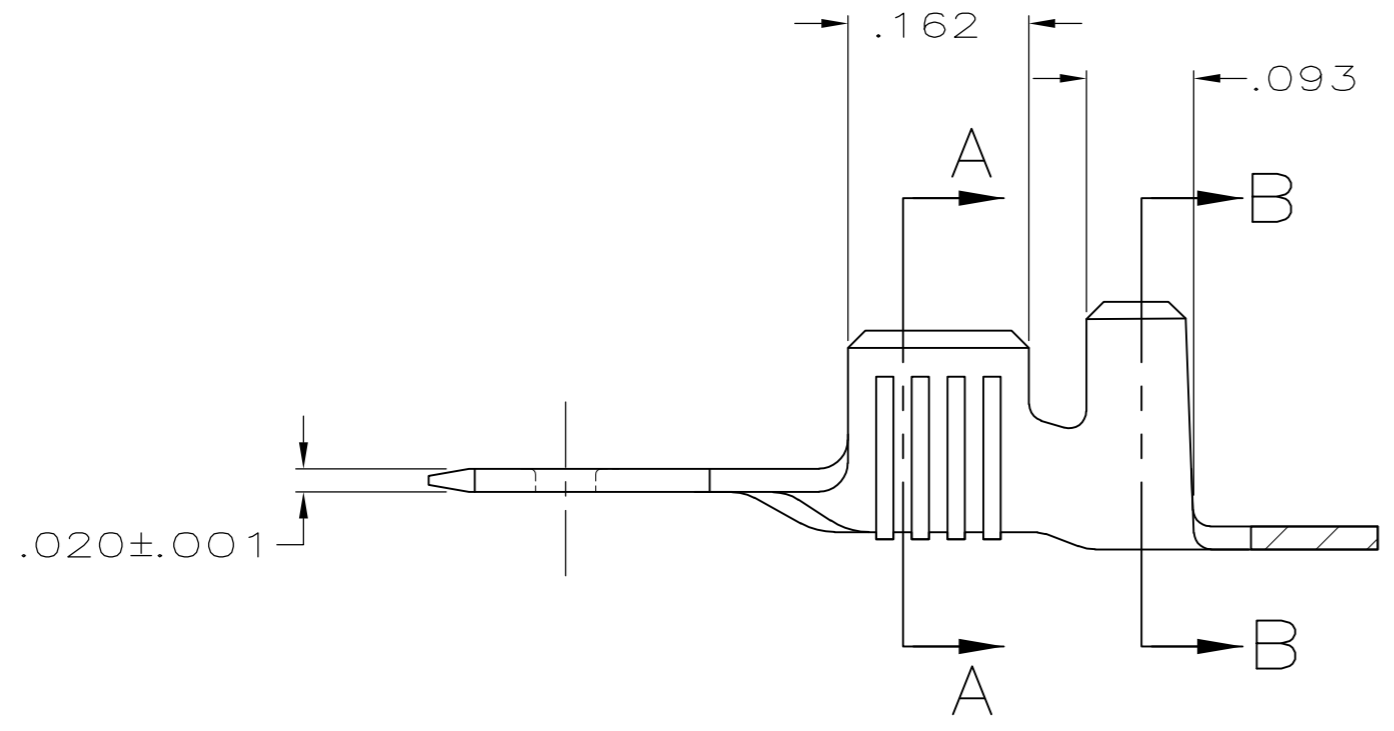

TIN	.120-.150	18-14	60850-2
FINISH	.120-.150	18-14	60850-1
INSULATION RANGE	WIRE RANGE	PART NO	

0	.180	.218	F	.110	.085	14	THIS DRAWING IS A CONTROLLED DOCUMENT. DIMENSIONS: INCHES 	TOLERANCES UNLESS OTHERWISE SPECIFIED: 0 PLC ± - 1 PLC ± - 2 PLC ± - 3 PLC ± .015 4 PLC ± - ANGLES ± - FINISH SEE TABLE	DWN JR RUTH 2/16/89 CHK MS FEHER 2/16/89 APVD C MEYERS 2/17/89 PRODUCT SPEC APPLICATION SPEC	TE TE Connectivity TAB,FASTON,.187 SERIES™ SIZE CAGE CODE DRAWING NO RESTRICTED TO A2 00779 C=60850 SCALE 6:1 SHEET 1 of 1 REV N	
TYPE	WIDTH	STRIP LENGTH ±.015	TYPE	WIDTH	±.002 HEIGHT	WIRE			WEIGHT		---
INSUL BARREL CRIMP		WIRE BARREL CRIMP							MATERIAL BRASS		CUSTOMER DRAWING