

THIS DOCUMENT IS THE PROPERTY OF
KEYSTONE ELECTRONICS CORP. AND
SHALL NOT BE REPRODUCED, DISTRIBUTED
OR USED AS A BASIS FOR MANUFACTURE
WITHOUT PRIOR WRITTEN PERMISSION
FROM KEYSTONE ELECTRONICS CORP.

ACTUAL SIZE

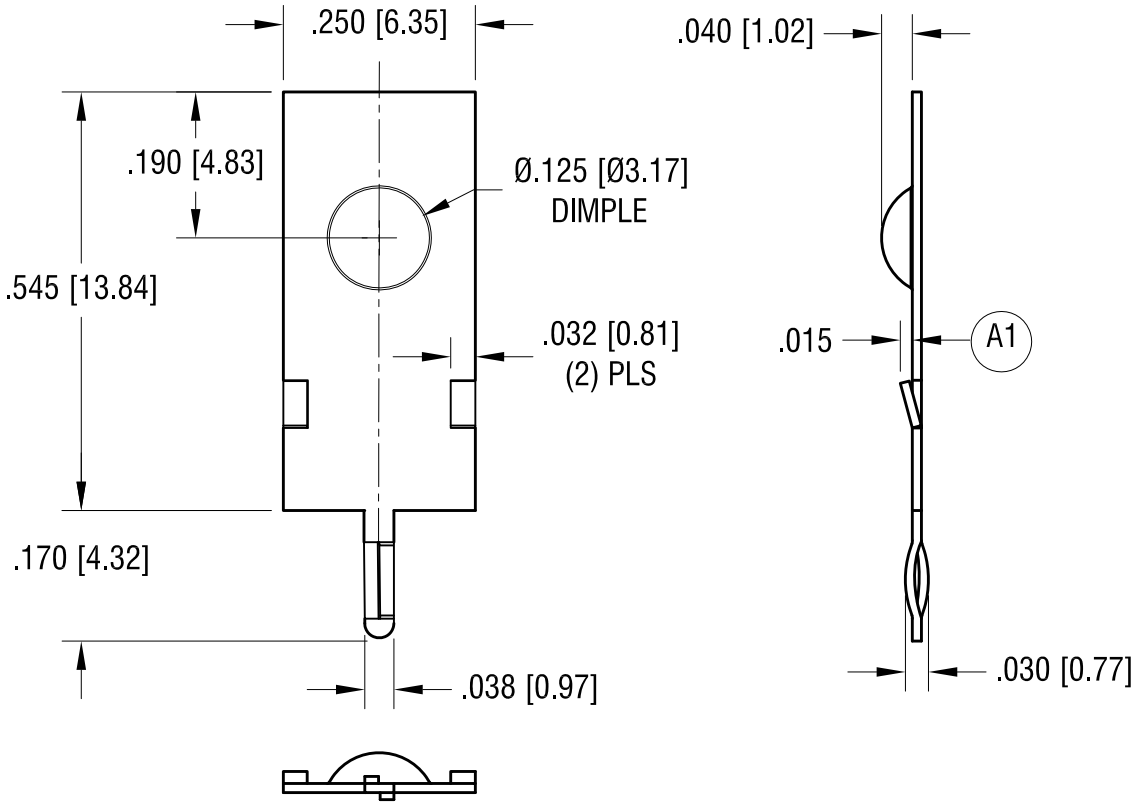

NOTE:

1. PART MUST BE FREE OF ALL BURRS AND SHARP EDGES.

KEYSTONE ELECTRONICS CORP.

www.keyelco.com • NEW HYDE PARK NY 11040 • Tel (516)328-7500

PART NAME		THM BATTERY CONTACT	
MATERIAL		.012 [0.30] TH'K STAINLESS STEEL	
FINISH	DRN BY	DATE	
TIN NICKEL PLATE	NT	5.19.14	
	APP'D	SCALE	
	LN	4X	
TOLERANCES	INCH	[MM]	CODE
DECIMAL	$\pm .005$	[± 0.13]	C
ANGULAR	$\pm 1^\circ$		
UNLESS OTHERWISE SPECIFIED			DWG NO.
			1011-1

11.09.21	REVERSE LANCES A1 CHANGE AS PER ECN 21-129	A
DATE	DESCRIPTION	REV.