

General Description

The V103A LVDS display interface transmitter is primarily designed to support pixel data transmission between a video processing engine and a digital video display. The data rate supports up to SXGA+ resolutions and can be used in Plasma, Rear Projector, Front Projector, CRT and LCD display applications. It can also be used in other high-bandwidth parallel data applications and provides a low EMI interconnect over a low cost, low bus width cable up to several meters in length.

The V103A converts 35 bits of CMOS/TTL data, clocked on the rising or falling edge of an input clock (selectable), into six LVDS (Low Voltage Differential Signaling) serial data stream pairs. In video applications the 35 bits is normally divided into 10 bits for each R, G and B channel and 5 control bits.

When combined with the V104 LVDS display interface receiver, the V103A + V104 combination provides a 35-bit wide, 90 MHz transport. The rate of each LVDS channel is 630 Mbps for a 90MHz data input clock, 945 Mbps for 135MHz.

Features

- Pin compatible with THine THC63LVD103
- Wide pixel clock range: 8 - 135 MHz
- Guaranteed operation over -20 to +85° C ambient temperature
- Supports a wide range of video and graphics modes including VGA, SVGA, XGA, SXGA, SXGA+, NTSC, PAL, SDTV, and HDTV up to 1080I or 720P
- Internal PLL requires no external loop filter
- Selectable rising or falling clock edge for data alignment
- Compatible with Spread Spectrum clock source
- Reduced LVDS output voltage swing mode (selectable) to minimize EMI
- CMOS/TTL data inputs can be configured for reduced input voltage swing
- Single 3.3 V supply
- Low power consumption CMOS design
- Power down mode
- 64-pin TQFP lead free package

Block Diagram

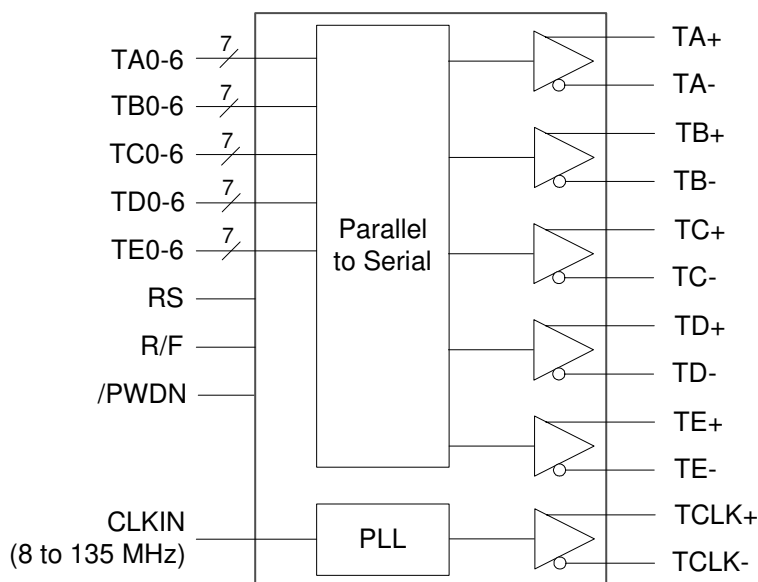

Pin Assignment

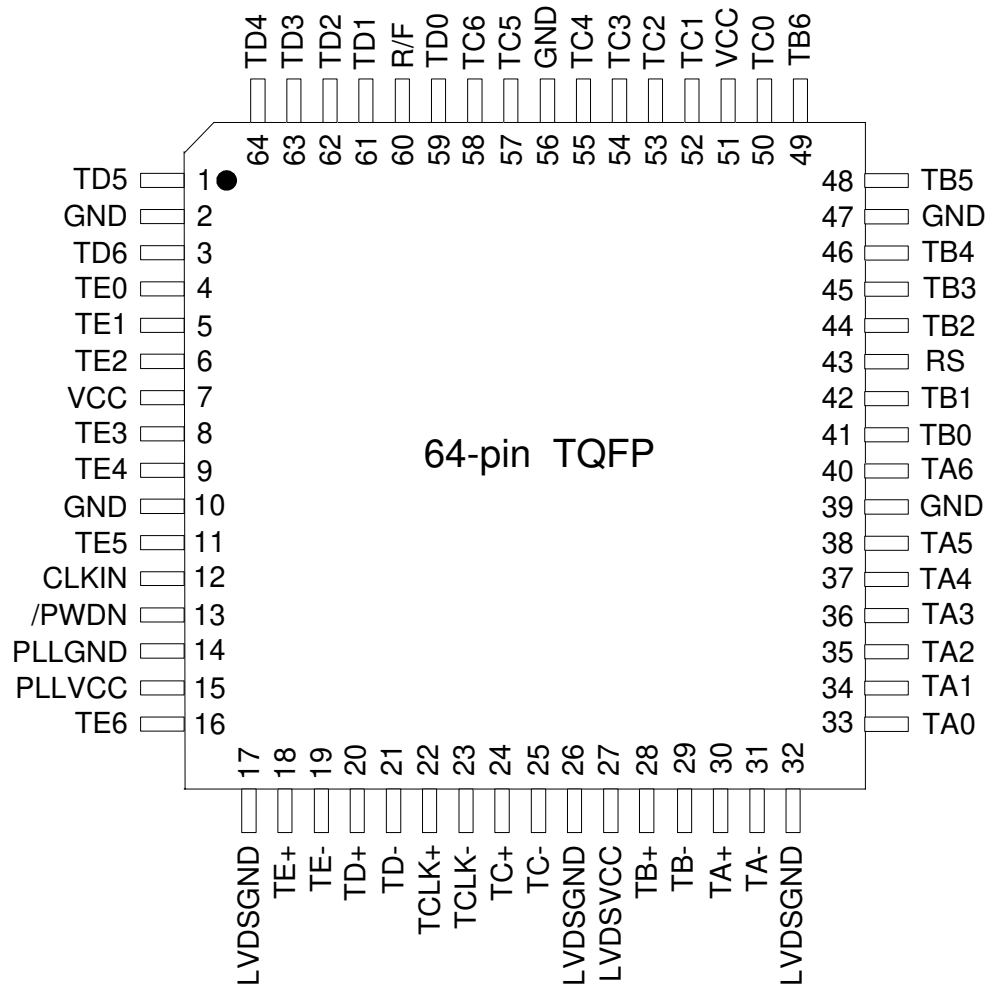

Pin Descriptions

Pin Number	Pin Name	Pin Type	Pin Description
30, 31	TA+, TA-	LVDS OUT	LVDS Serial Data Output Pairs
28, 29	TB+, TB-		
24, 25	TC+, TC-		
20, 21	TD+, TD-		
18, 19	TE+, TE-		
22, 23	TCLK+, TCLK-	LVDS OUT	LVDS Reference Clock Output Pair
33, 34, 35, 36, 37, 38, 40	TA0 ~ TA6	IN	CMOS/TTL (or small signal) Data Bit Inputs
41, 42, 44, 45, 46, 48, 49	TB0 ~ TB6		
50, 52, 53, 54, 55, 57, 58	TC0 ~ TC6		
59, 61, 62, 63, 64, 1, 3	TD0 ~ TD6		
4, 5, 6, 8, 9, 11, 16	TE0 ~ TE6		
13	/PWDN	IN	High: Normal device operation Low: Power down; all outputs become high impedance
43	RS	IN	Voltage level on this pin sets LVDS output swing voltage and data input swing voltage; refer to the table at the bottom of this page.
60	R/F	IN	Input Clock triggering edge select. High: Rising edge; Low: Falling edge.
51, 7	VCC	Power	Power supply pins for TTL inputs and digital circuitry.
12	CLKIN	IN	Clock Input.
2, 10, 39, 47, 56	GND	Ground	Ground pins for TTL inputs and digital circuitry.
27	LVDSVCC	Power	Power supply pins for LVDS outputs.
17, 26, 32	LVDSGND	Ground	Ground pins for LVDS outputs.
15	PLLVCC	Power	Power supply pin for PLL circuitry.
14	PLLGND	Ground	Ground pin for PLL circuitry.

RS Input Voltage Configuration to set LVDS Output Swing and Data Input Swing

RS Input Voltage	LVDS Output Swing	CMOS/TTL Input Configuration (Input Voltage Swing)
VCC	350 mV	Standard Configuration ¹
0.6 ~ 1.4 V (VREF ¹)	350 mV	Small Input Swing Configuration ¹
GND	200 mV	Standard Configuration ¹

Note 1: Refer to DC Electrical Characteristics.

External Components

Decoupling capacitors should be used for all power pins. The V103A requires no other external components.

Absolute Maximum Ratings

Stresses above the ratings listed below can cause permanent damage to the V103A. These ratings, which are standard values for ICS commercially rated parts, are stress ratings only. Functional operation of the device at these or any other conditions above those indicated in the operational sections of the specifications is not implied. Exposure to absolute maximum rating conditions for extended periods can affect product reliability. Electrical parameters are guaranteed only over the recommended operating temperature range.

Item	Rating
Supply Voltage, VCC	-0.3 V to +4.0 V
CMOS/TTL Input Voltage	-0.3 V to VCC+0.3 V
CMOS/TTL Output Voltage	-0.3 V to VCC+0.3 V
LVDS Driver Output Voltage	-0.3 V to VCC+0.3 V
Storage Temperature	-55 to +150°C
Junction Temperature	120°C
Soldering Temperature (10 seconds)	260°C
Maximum Power Dissipation @ 25°C	1.0 W

Recommended Operation Conditions

Parameter	Min.	Typ.	Max.	Units
Ambient Operating Temperature	-20		+85	°C
Power Supply Voltage (measured in respect to GND)	+3.0	+3.3	+3.6	V

DC Electrical Characteristics

VDD=3.3 V ±10%, Ambient temperature -20 to +85°C

Parameter	Symbol	Conditions	Min.	Typ.	Max.	Units
CMOS/TTL Inputs, Standard Configuration						
Input High Voltage	V_{IH}	RS=VCC or GND	2.00		VCC	V
Input Low Voltage	V_{IL}	RS=VCC or GND	GND		0.80	V
Input Current	I_{INC}	$0V \leq V_{IN} \leq VCC$			±10	μA
CMOS/TTL Inputs, Small Input Swing Configuration						
Max Input Swing Voltage	V_{DDQ}^1	$V_{REF} = V_{RS} = V_{DDQ}/2$	1.2	$V_{DDQ}/2$	2.8	V
Input Reference Voltage into pin RS	V_{REF}					
High Level Input Voltage (for small input swing condition)	V_{SH}^2	$V_{REF}=V_{DDQ}/2$	$V_{DDQ}/2$ +0.1V			V
Low Level Input Voltage (for small input swing condition)	V_{SL}^2	$V_{REF}=V_{DDQ}/2$			$V_{DDQ}/2$ -0.1V	V

Note 1: V_{DDQ} voltage defines the max voltage of the small swing input and is not an actual input into the device.

Note 2: Small input swing voltage is applied to TA[6:0], TB[6:0], TC[6:0], TD[6:0], TE[6:0], and CLKIN.

LVDS Transmitter DC Specifications						
Differential Output Voltage, $R_L = 100\Omega$	V_{OD}	Normal swing RS = VCC	250	350	450	mV
		Reduced swing RS = GND	100	200	300	mV
Change in V_{OD} Between Complimentary Output States	DV_{OD}	RL = 100Ω			35	mV
Common Mode Voltage	V_{OC}		1.125	1.250	1.375	V
Change in V_{OC} Between Complimentary Output States	DV_{OC}				35	mV
Output Short Circuit Current	I_{OS}	$V_{OUT} = 0V, R_L = 100\Omega$			-24	mA
Output Tri-State Current	I_{OZ}	/PWDN = 0V, $V_{OUT} = 0V$ to VCC			±10	μA

Supply Current						
Transmitter Supply Current	I_{TCCG}	$R_L = 100\Omega, C_L = 5\text{ pF},$ VCC = 3.3 V, RS = VCC Gray Scale Pattern	f = 85 MHz	58	64	mA
			f = 135 MHz	70	76	mA
		$R_L = 100\Omega, C_L = 5\text{ pF},$ VCC = 3.3 V, RS = GND Gray Scale Pattern	f = 85 MHz	44	50	mA
			f = 135 MHz	56	62	mA
Transmitter Supply Current	I_{TCCW}	$R_L = 100\Omega, C_L = 5\text{ pF},$ VCC = 3.3 V, RS = VCC Worst Case Pattern	f = 85 MHz	69	75	mA
			f = 135 MHz	87	93	mA
		$R_L = 100\Omega, C_L = 5\text{ pF},$ VCC = 3.3 V, RS = GND Worst Case Pattern	f = 85 MHz	55	61	mA
			f = 135 MHz	73	79	mA
Transmitter Power Down Supply Current	I_{TCCS}	/PWDN = L			10	μA

Gray Scale Pattern

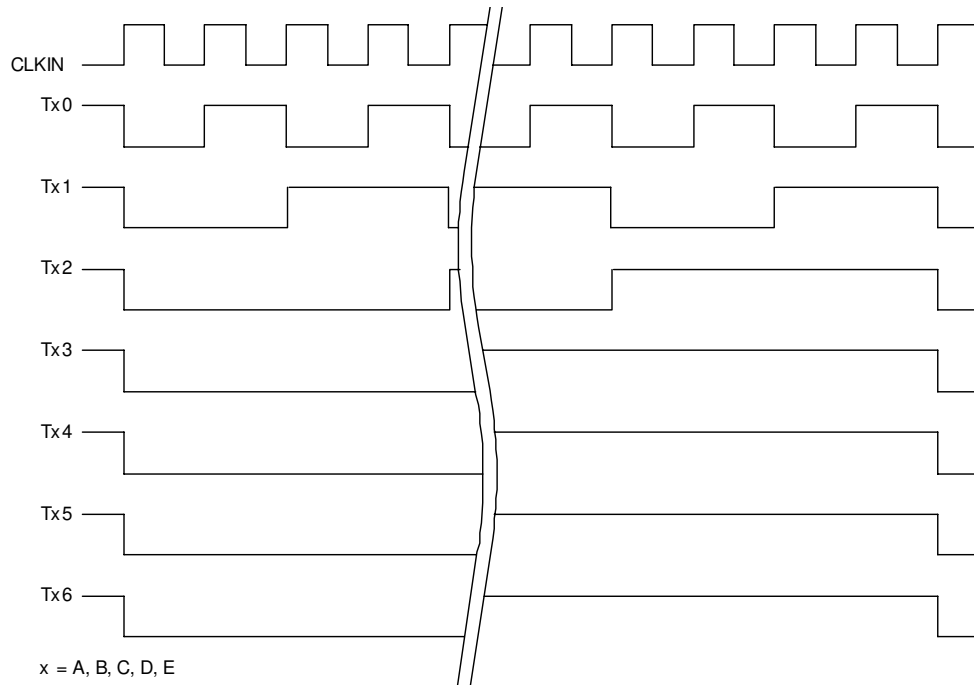

Worst Case Pattern

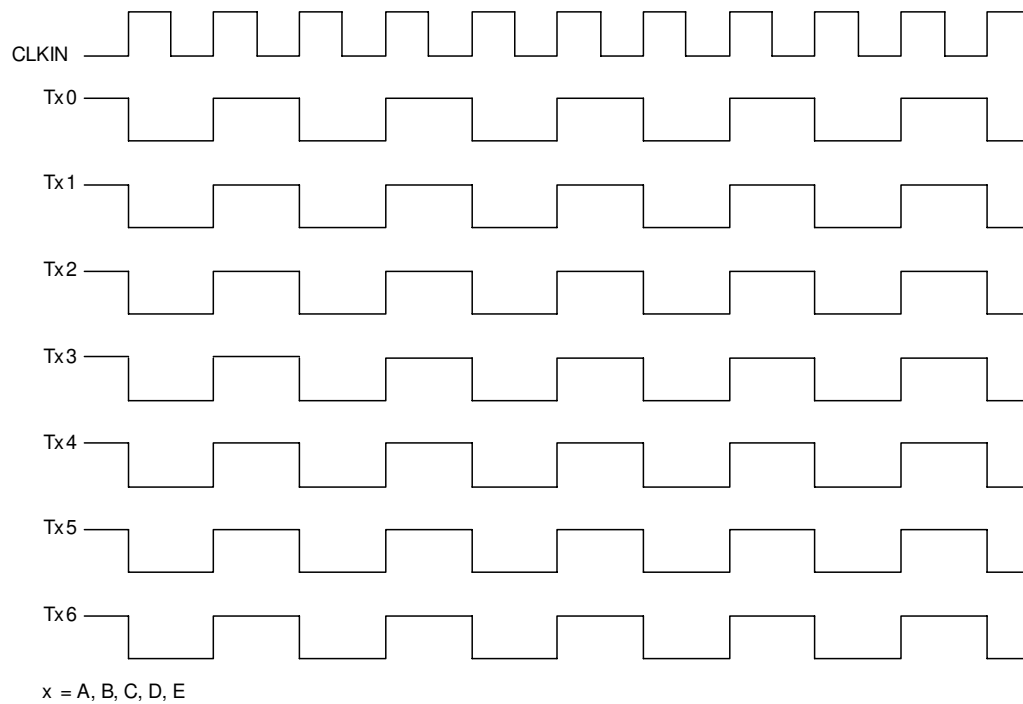

AC Electrical Characteristics

VDD=3.3 V ±10%, Ambient temperature -20 to +85°C

Parameter	Symbol	Min.	Typ.	Max.	Units
Switching Characteristics					
CLK IN Transition Time	t_{TCIT}			5	ns
CLK IN Period	t_{TCP}	7.4		125.0	ns
CLK IN High Time	t_{TCH}	$0.35t_{TCP}$	$0.5t_{TCP}$	$0.65t_{TCP}$	ns
CLK IN Low Time	t_{TCL}	$0.35t_{TCP}$	$0.5t_{TCP}$	$0.65t_{TCP}$	ns
CLK IN to TCLK± Delay	t_{TCD}		$3t_{TCP}$		ns
TTL Data Setup to CLK IN	t_{TS}	2.5			ns
TTL Data Hold from CLK IN	t_{TH}	0			ns
LVDS Transition Time	t_{LVT}		0.6	1.5	ns
Output Data Position0	t_{TOP1}	-0.2	0.0	0.2	ns
Output Data Position1	t_{TOP0}	$\frac{t_{TCP}}{7} - 0.2$	$\frac{t_{TCP}}{7}$	$\frac{t_{TCP}}{7} + 0.2$	ns
Output Data Position2	t_{TOP6}	$2 \frac{t_{TCP}}{7} - 0.2$	$2 \frac{t_{TCP}}{7}$	$2 \frac{t_{TCP}}{7} + 0.2$	ns
Output Data Position3	t_{TOP5}	$3 \frac{t_{TCP}}{7} - 0.2$	$3 \frac{t_{TCP}}{7}$	$3 \frac{t_{TCP}}{7} + 0.2$	ns
Output Data Position4	t_{TOP4}	$4 \frac{t_{TCP}}{7} - 0.2$	$4 \frac{t_{TCP}}{7}$	$4 \frac{t_{TCP}}{7} + 0.2$	ns
Output Data Position5	t_{TOP3}	$5 \frac{t_{TCP}}{7} - 0.2$	$5 \frac{t_{TCP}}{7}$	$5 \frac{t_{TCP}}{7} + 0.2$	ns
Output Data Position6	t_{TOP2}	$6 \frac{t_{TCP}}{7} - 0.2$	$6 \frac{t_{TCP}}{7}$	$6 \frac{t_{TCP}}{7} + 0.2$	ns
Phase Lock Loop Set	t_{TPLL}			10.0	ms

Thermal Characteristics

Parameter	Symbol	Conditions	Min.	Typ.	Max.	Units
Thermal Resistance Junction to Ambient	θ_{JA}	Still air		53		°C/W
	θ_{JA}	1 m/s air flow		40		°C/W
	θ_{JA}	3 m/s air flow		33		°C/W
Thermal Resistance Junction to Case	θ_{JC}			8		°C/W

AC Timing Diagrams

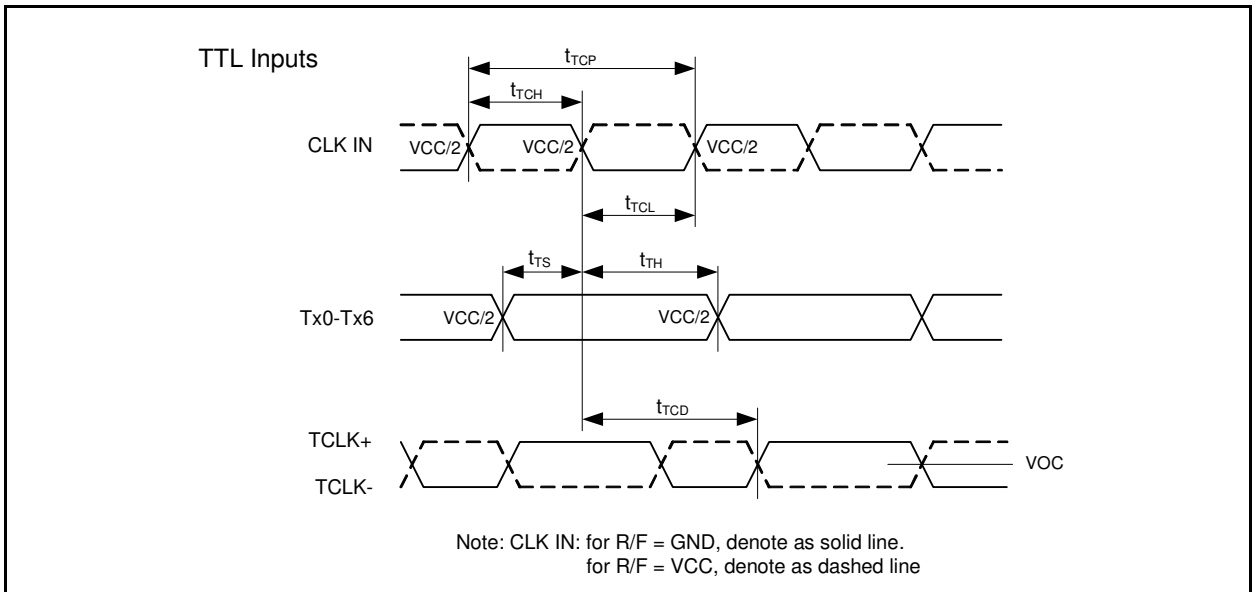
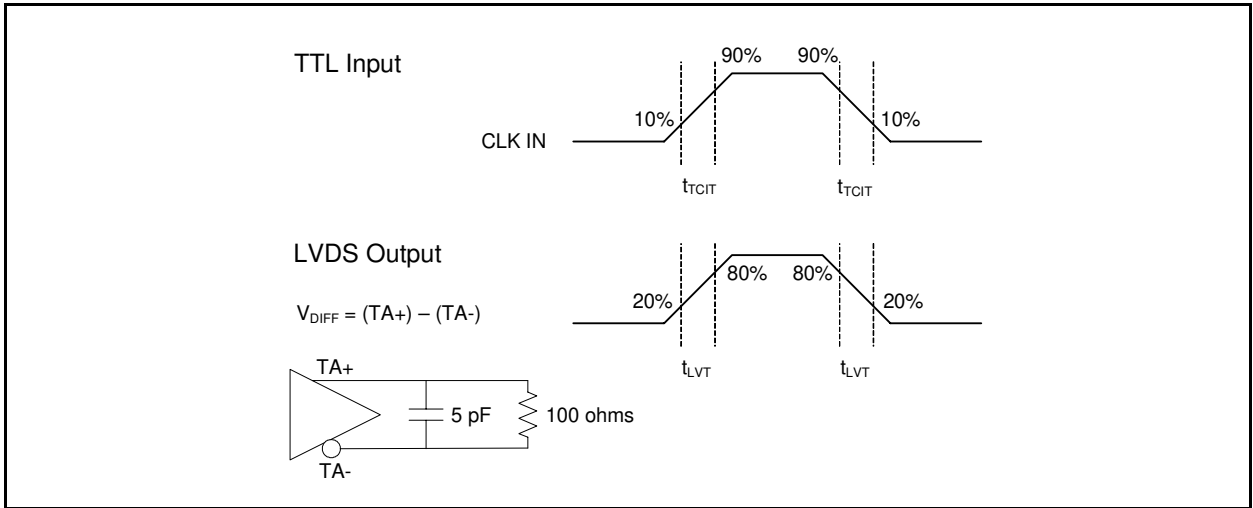

V103A **RENESAS**
TRIPLE 10-BIT LVDS TRANSMITTER FOR VIDEO

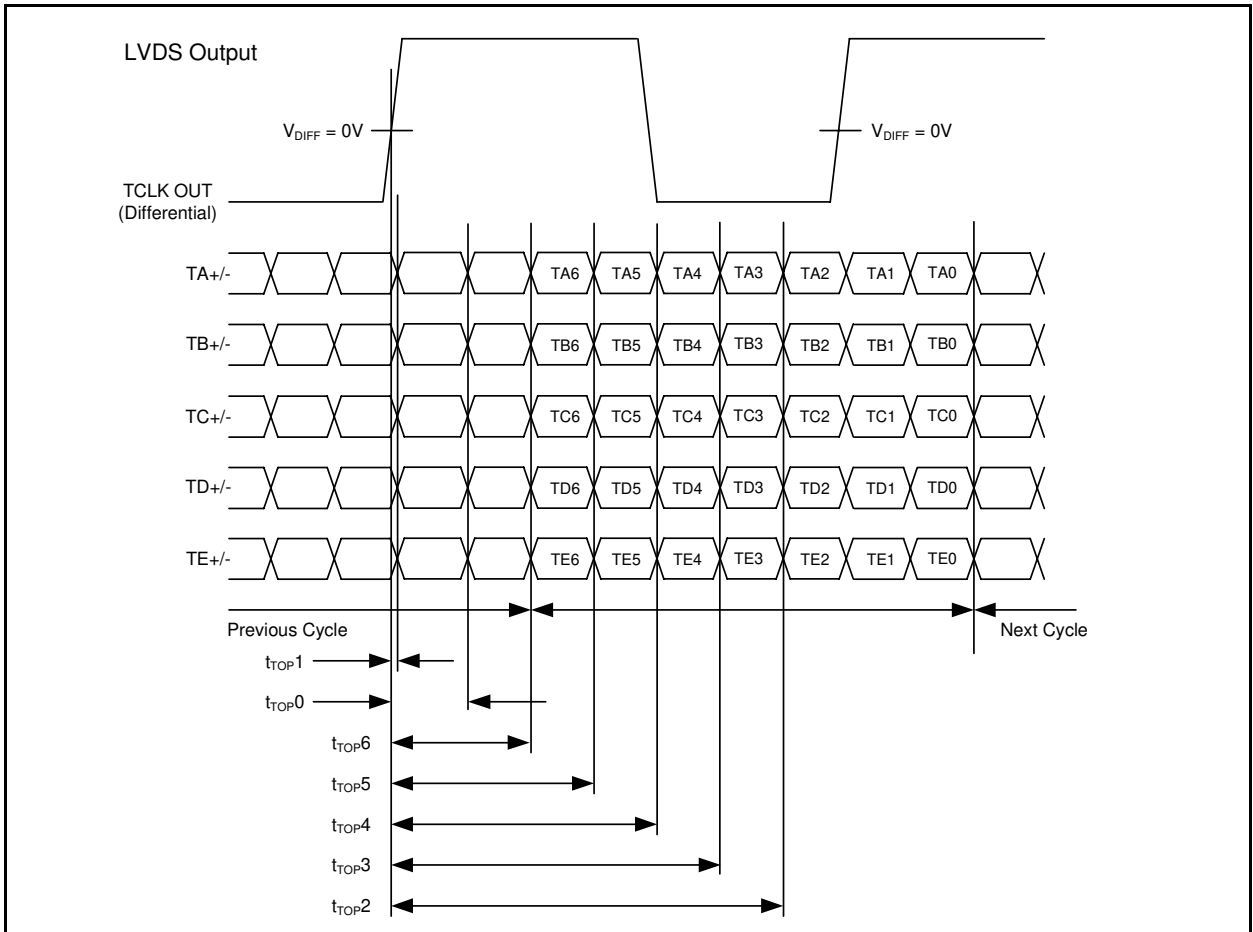
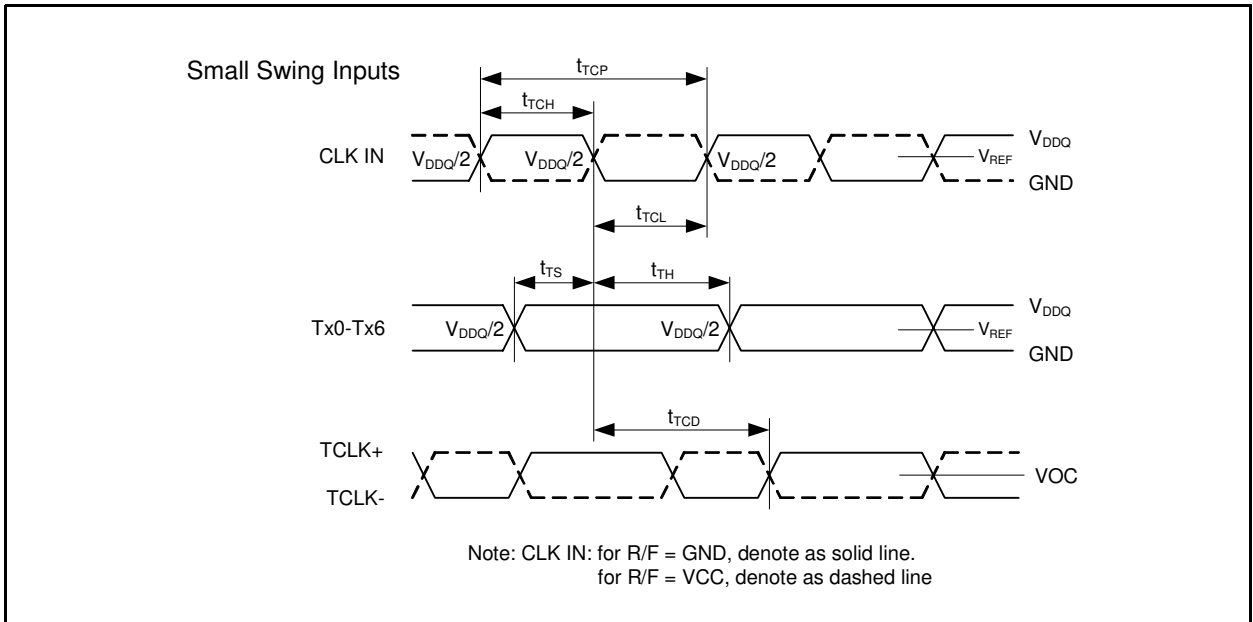

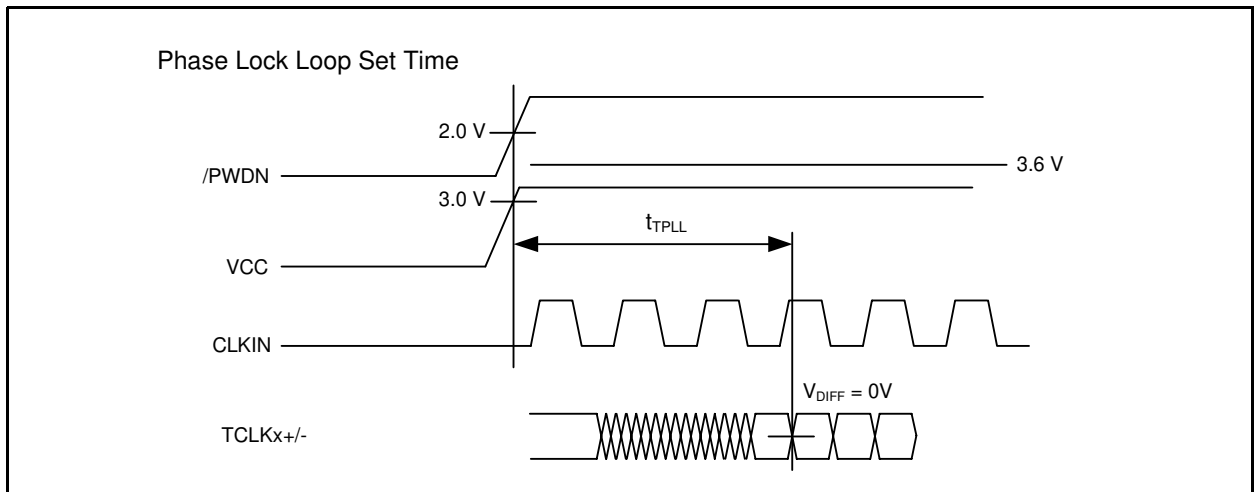

Package Outline and Package Dimensions (64-pin TQFP)

Package dimensions are kept current with JEDEC Publication No. 95, variation ACD.

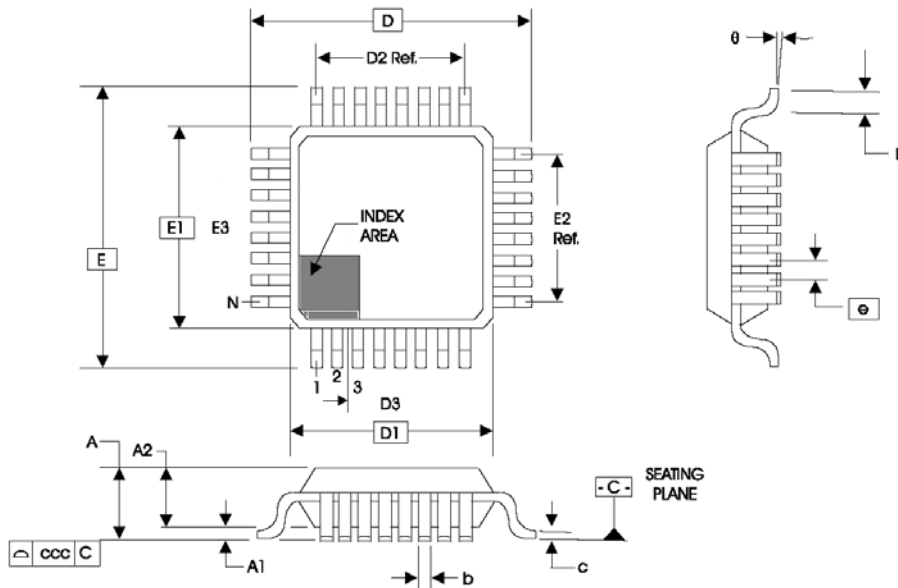

ALL DIMENSIONS ARE IN MILLIMETERS.

SYMBOL	MIN/MAX
N	64
A	-- / 1.20
A1	0.05 / 0.15
A2	0.95 / 1.05
b	0.17 / 0.27
c	0.09 / 0.20
D	12.00 BASIC
D1	10.00 BASIC
D2	7.50 Ref.
E	12.00 BASIC
E1	10.00 BASIC
E2	7.50 Ref.
e	0.50 BASIC
L	0.45 / 0.75
theta	0° / 7°
ccc	-- / 0.08
D3&E3	-

Ordering Information

Part / Order Number	Marking	Shipping Packaging	Package	Temperature
V103AYLF	V103AYLF	Tray (160 units per tray)	64-pin TQFP	-20 to +85° C
V103AYLFT	V103AYLF	Tape and Reel	64-pin TQFP	-20 to +85° C

The "LF" part number suffix denotes the device as Lead (Pb) Free and that the device is RoHS compliant.

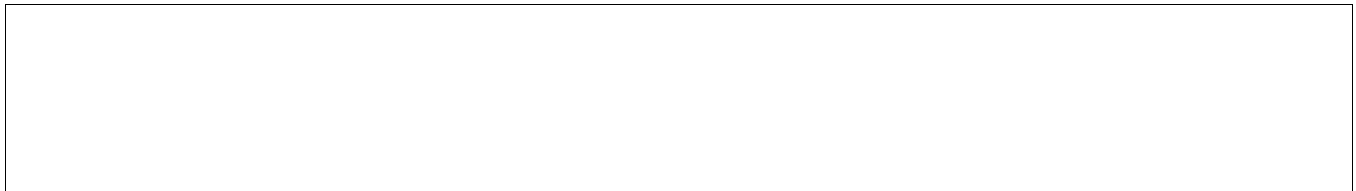

IMPORTANT NOTICE AND DISCLAIMER

RENESAS ELECTRONICS CORPORATION AND ITS SUBSIDIARIES (“RENESAS”) PROVIDES TECHNICAL SPECIFICATIONS AND RELIABILITY DATA (INCLUDING DATASHEETS), DESIGN RESOURCES (INCLUDING REFERENCE DESIGNS), APPLICATION OR OTHER DESIGN ADVICE, WEB TOOLS, SAFETY INFORMATION, AND OTHER RESOURCES “AS IS” AND WITH ALL FAULTS, AND DISCLAIMS ALL WARRANTIES, EXPRESS OR IMPLIED, INCLUDING, WITHOUT LIMITATION, ANY IMPLIED WARRANTIES OF MERCHANTABILITY, FITNESS FOR A PARTICULAR PURPOSE, OR NON-INFRINGEMENT OF THIRD PARTY INTELLECTUAL PROPERTY RIGHTS.

These resources are intended for developers skilled in the art designing with Renesas products. You are solely responsible for (1) selecting the appropriate products for your application, (2) designing, validating, and testing your application, and (3) ensuring your application meets applicable standards, and any other safety, security, or other requirements. These resources are subject to change without notice. Renesas grants you permission to use these resources only for development of an application that uses Renesas products. Other reproduction or use of these resources is strictly prohibited. No license is granted to any other Renesas intellectual property or to any third party intellectual property. Renesas disclaims responsibility for, and you will fully indemnify Renesas and its representatives against, any claims, damages, costs, losses, or liabilities arising out of your use of these resources. Renesas' products are provided only subject to Renesas' Terms and Conditions of Sale or other applicable terms agreed to in writing. No use of any Renesas resources expands or otherwise alters any applicable warranties or warranty disclaimers for these products.

(Disclaimer Rev.1.0 Mar 2020)

Corporate Headquarters

TOYOSU FORESIA, 3-2-24 Toyosu,
Koto-ku, Tokyo 135-0061, Japan
www.renesas.com

Contact Information

For further information on a product, technology, the most up-to-date version of a document, or your nearest sales office, please visit:
www.renesas.com/contact/

Trademarks

Renesas and the Renesas logo are trademarks of Renesas Electronics Corporation. All trademarks and registered trademarks are the property of their respective owners.