DM320016 – PCAP Touch Pad Development Kit with Gestures Product Brief

INTRODUCTION

Microchip's Projected Capacitive Touch Pad Development Kit with Gestures showcases the high performance and the flexible design of Microchip's MTCH6301 projected capacitive touch controller. This development kit also allows designers to test functionality, including multi-touch and gestures.

After connecting to a PC with the included PICKit™ Serial Analyzer (PKSA), developers may also interact with the MTCH6301 user parameters through the Projected Capacitive Configuration Utility (PCU), GUI program. For this program and more information about Microchip's touch portfolio, please visit www.microchip.com/mTouch.

DEVELOPMENT KIT FEATURES

- Includes a modified MTCH6301 to provide touch input and also drive the dot-matrix LCD
- Multi-touch detection up to eight touches
- Microchip's CVD capacitive sensing method
- Sleep with wake-on-touch
- Dual-touch drawing
- Single-touch gestures
- PCU software allows observation of signals and tuning of firmware parameters

BASIC REQUIREMENTS

- Two AAA Batteries
- 32- or 64-bit Windows® XP or Windows 7 development environment
- PICKit Serial Analyzer (Included):
 - Updated with `PKSpCap406.hex`
- USB *mini* Cable (Included)
- Male 6-pin Connector (Included)
- PCU, v 2.03 or later (available from the DM320016 device page).

GETTING STARTED

There are two switches mounted on the board: switch SW1 toggles the power and switch SW2 selects the Demo or Development mode. The included PKSA has been programmed to function as a USB-to-I²C™ communication bridge. The PKSA is necessary to communicate with the development software, PCU.

DEMO MODE OPERATION

This mode is intended for stand-alone use to demonstrate the gestures and multi-touch capabilities of Microchip's MTCH6301 projected capacitive controller. Toggle SW1 to **ON** and toggle SW2 to **DEMO** to use the Demo mode. The display will provide visual feedback, as the touch pad area is activated with a finger.

Note: Demo mode is for stand-alone use. The PC software, GUI, will not connect to the device while in this mode.

Single or Two-finger Draw

Draw on the touch pad and see the fully-processed touch coordinates on the display. Performing a double-tap gesture will clear the display.

Sleep Mode

The device will automatically go into Sleep mode after eight seconds of inactivity (see [Figure 1](#)).

FIGURE 1: SLEEP MODE



Mini Map

The Mini Map displays the finger location and the number of touches detected (see [Figure 2](#)).



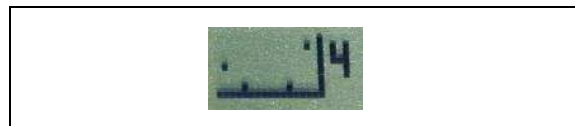







FIGURE 2: MINI MAP



Single-Touch Gestures

Perform one of these single-touch gestures decoded in firmware and see the icon in the display below.

FIGURE 3: SINGLE-TOUCH GESTURES

	Single Tap
	Double Tap
	Tap and Hold
	Swipe Up
	Swipe Up and Hold
	Swipe Down
	Swipe Down and Hold
	Swipe Left
	Swipe Left and Hold
	Swipe Right
	Swipe Right and Hold

DEVELOPMENT MODE OPERATION

This mode is intended to allow the device to connect to a PC through the PKSA for evaluation with Microchip's PCU. The PCU must be installed on your local machine to utilize this mode. Please download this utility from the DM320016 device page.

- Toggle SW1 to **OFF** (PKSA will supply power)
- Toggle SW2 to **DEV**
- Connect PKSA to PKS header using the included 6-pin header
- Connect USB *mini* cable between PKSA and host PC
- Launch PCU utility and confirm the board is connected

The PCU will connect automatically and display the green **CONNECTED** status, and all tabs and parameter adjustments are accessible.

Please reference the PCU manual (www.microchip.com/pagehandler/en-us/technology/mtouch-screens/resources/software.html) and the MTCH6301 device page (<http://www.microchip.com/wwwproducts/Devices.aspx?product=MTCH6301>) for more details to evaluate this design.

FIGURE 4: KIT CONFIGURATION

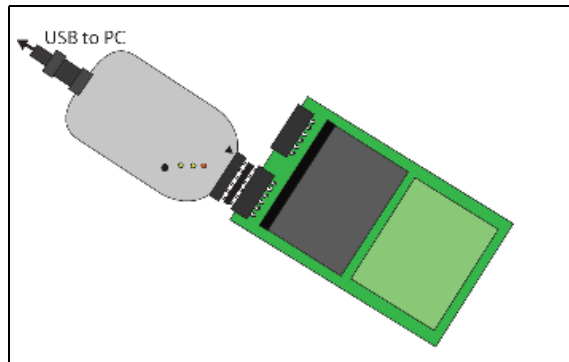

PROGRAMMING

There is a header included on the board for programming the MTCH6301. This header is marked PGM.

Supported Microchip programming devices include:

- PICKit™ 3
- ICD 3

RESTORING FACTORY DEFAULTS

While using the PCU software, it is possible to adjust particular settings outside of expected operating ranges. It may be necessary to force the board to factory default settings to restore functionality.

To restore the DM320016 to factory defaults:

- Detach the DM320016 from all devices before turning SW1 to the **OFF** position and the SW2 switch to the **DEV** position
- Connect the PKSA to the PKS header
- Open the PCAP Configuration Utility and click the **SHOW ADVANCED PARAMETERS** check box in the lower left-hand corner, which will display a list of additional options
- Click the **RESTORE FACTORY DEFAULTS** button
- Wait for the **CONTROLLER FACTORY DEFAULTS RESTORED** text to appear
- Close the utility and disconnect the DM320016

Once the DM320016 stops receiving power from the PKSA, the factory defaults will be restored. To verify that the device has been restored, move SW2 so that **DEMO** is selected and change SW1 to the **ON** position. Normal operation should be restored.

APPENDIX A:
FIGURE A-1: SCHEMATICS

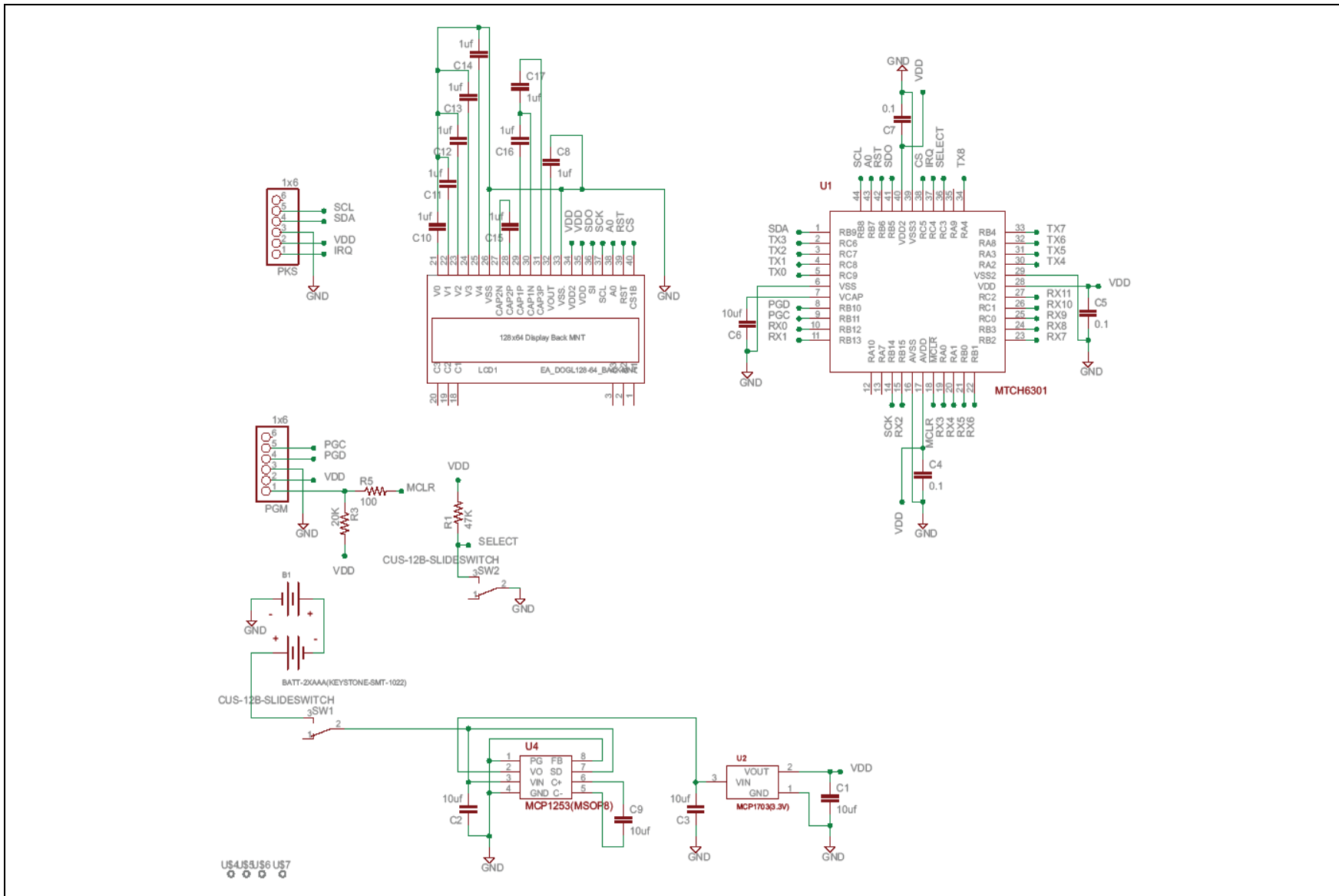

TABLE 1: BILL OF MATERIALS/ASSEMBLY

No.	Designator	Quantity	Description	OEM		Source	Distributor	\$ ea.	\$ Total	Equiv. Allowed
				Manufacturer	Part number		Part No.			
1	B1	1	Holder Battery AAA SMD Dual	Keystone Electronics	1022				0.000	√
2	C1, C2, C3, C6, C9	5	CAP CER 10 uF 6.3V 20% X5R 0603	TDK Corporation	C1608X5R0J106M				0.000	√
3	C4, C5, C7	3	CAP CER 0.1 uF 50V 10% X7R 0603	Murata Electronics North America	GCM188R71H104- KA57D				0.000	√
4	C8, C10, C11, C12, C13, C14, C15, C16, C17	9	CAP CER 1 uF 10V 10% X5R 0603	Murata Electronics North America	GRM188R61A105- KA61D				0.000	√
5	PGM, PKS	2	CONN Female 6 Pos. 100" r/a TIN	Sullins Connector Solutions	PPTC061LGBN-RC				0.000	√
6	LCD1	1	LCD Graphic Display Modules & Accessories FSTN(+) Transflectv White Background	ELECTRONIC ASSEMBLY	EA DOGL128W-6				0.000	
7	R1	1	RES 47 K Ω 1/10W 5% 0603 SMD	Panasonic – ECG	ERJ-3GEYJ473V				0.000	√
8	R3	1	RES 20 K Ω 1/10W 5% 0603 SMD	Panasonic – ECG	ERJ-3GEYJ203V				0.000	√
9	R5	1	RES 100 Ω 1/10W 5% 0603 SMD	Panasonic – ECG	ERJ-3GEYJ101V				0.000	√
10	SW1, SW2	2	Switch Slide SPDT Low Prof SMD	Copal Electronics Inc.	CUS-12TB				0.000	√
11	U1	1	IC MCU 32-bit 32-Kb Flash 44 TQFP	Microchip Technology	MTCH6301-I/PT				0.000	
12	U2	1	IC REG LDO 3.3V 250 mA SOT-23A	Microchip Technology	MCP1703T-3302E/CB				0.000	
13	U4	1	IC Mult Config 3.3/5V 12A 8 MSOP	Microchip Technology	MCP1253T-33X50I/MS				0.000	
14	LENS	1	0.060" Clear Acrylic with 3M 7952 MP Adhesive Back, 2.36x3.06"						0.000	√
15	BATTERY	2	2xAAA Batteries	ENERGIZER	AAA				0.000	√

Note the following details of the code protection feature on Microchip devices:

- Microchip products meet the specification contained in their particular Microchip Data Sheet.
- Microchip believes that its family of products is one of the most secure families of its kind on the market today, when used in the intended manner and under normal conditions.
- There are dishonest and possibly illegal methods used to breach the code protection feature. All of these methods, to our knowledge, require using the Microchip products in a manner outside the operating specifications contained in Microchip's Data Sheets. Most likely, the person doing so is engaged in theft of intellectual property.
- Microchip is willing to work with the customer who is concerned about the integrity of their code.
- Neither Microchip nor any other semiconductor manufacturer can guarantee the security of their code. Code protection does not mean that we are guaranteeing the product as “unbreakable.”

Code protection is constantly evolving. We at Microchip are committed to continuously improving the code protection features of our products. Attempts to break Microchip's code protection feature may be a violation of the Digital Millennium Copyright Act. If such acts allow unauthorized access to your software or other copyrighted work, you may have a right to sue for relief under that Act.

Information contained in this publication regarding device applications and the like is provided only for your convenience and may be superseded by updates. It is your responsibility to ensure that your application meets with your specifications. MICROCHIP MAKES NO REPRESENTATIONS OR WARRANTIES OF ANY KIND WHETHER EXPRESS OR IMPLIED, WRITTEN OR ORAL, STATUTORY OR OTHERWISE, RELATED TO THE INFORMATION, INCLUDING BUT NOT LIMITED TO ITS CONDITION, QUALITY, PERFORMANCE, MERCHANTABILITY OR FITNESS FOR PURPOSE. Microchip disclaims all liability arising from this information and its use. Use of Microchip devices in life support and/or safety applications is entirely at the buyer's risk, and the buyer agrees to defend, indemnify and hold harmless Microchip from any and all damages, claims, suits, or expenses resulting from such use. No licenses are conveyed, implicitly or otherwise, under any Microchip intellectual property rights.

Trademarks

The Microchip name and logo, the Microchip logo, dsPIC, FlashFlex, KEELOQ, KEELOQ logo, MPLAB, PIC, PICmicro, PICSTART, PIC³² logo, rPIC, SST, SST Logo, SuperFlash and UNI/O are registered trademarks of Microchip Technology Incorporated in the U.S.A. and other countries.

FilterLab, Hampshire, HI-TECH C, Linear Active Thermistor, MTP, SEEVAL and The Embedded Control Solutions Company are registered trademarks of Microchip Technology Incorporated in the U.S.A.

Silicon Storage Technology is a registered trademark of Microchip Technology Inc. in other countries.

Analog-for-the-Digital Age, Application Maestro, BodyCom, chipKIT, chipKIT logo, CodeGuard, dsPICDEM, dsPICDEM.net, dsPICworks, dsSPEAK, ECAN, ECONOMONITOR, FanSense, HI-TIDE, In-Circuit Serial Programming, ICSP, Mindi, MiWi, MPASM, MPF, MPLAB Certified logo, MPLIB, MPLINK, mTouch, Omniclient Code Generation, PICC, PICC-18, PICDEM, PICDEM.net, PICkit, PICtail, REAL ICE, rLAB, Select Mode, SQI, Serial Quad I/O, Total Endurance, TSHARC, UniWinDriver, WiperLock, ZENA and Z-Scale are trademarks of Microchip Technology Incorporated in the U.S.A. and other countries.

SQTP is a service mark of Microchip Technology Incorporated in the U.S.A.

GestIC and ULPP are registered trademarks of Microchip Technology Germany II GmbH & Co. KG, a subsidiary of Microchip Technology Inc., in other countries.

All other trademarks mentioned herein are property of their respective companies.

© 2014, Microchip Technology Incorporated, Printed in the U.S.A., All Rights Reserved.

 Printed on recycled paper.

ISBN: 9781620779262

QUALITY MANAGEMENT SYSTEM
CERTIFIED BY DNV
== ISO/TS 16949 ==

Microchip received ISO/TS-16949:2009 certification for its worldwide headquarters, design and wafer fabrication facilities in Chandler and Tempe, Arizona; Gresham, Oregon and design centers in California and India. The Company's quality system processes and procedures are for its PIC® MCUs and dsPIC® DSCs, KEELOQ® code hopping devices, Serial EEPROMs, microperipherals, nonvolatile memory and analog products. In addition, Microchip's quality system for the design and manufacture of development systems is ISO 9001:2000 certified.



MICROCHIP

Worldwide Sales and Service

AMERICAS

Corporate Office
2355 West Chandler Blvd.
Chandler, AZ 85224-6199
Tel: 480-792-7200
Fax: 480-792-7277
Technical Support:
<http://www.microchip.com/support>
Web Address:
www.microchip.com

Atlanta
Duluth, GA
Tel: 678-957-9614
Fax: 678-957-1455

Austin, TX
Tel: 512-257-3370

Boston
Westborough, MA
Tel: 774-760-0087
Fax: 774-760-0088

Chicago
Itasca, IL
Tel: 630-285-0071
Fax: 630-285-0075

Cleveland
Independence, OH
Tel: 216-447-0464
Fax: 216-447-0643

Dallas
Addison, TX
Tel: 972-818-7423
Fax: 972-818-2924

Detroit
Novi, MI
Tel: 248-848-4000

Houston, TX
Tel: 281-894-5983

Indianapolis
Noblesville, IN
Tel: 317-773-8323
Fax: 317-773-5453

Los Angeles
Mission Viejo, CA
Tel: 949-462-9523
Fax: 949-462-9608

New York, NY
Tel: 631-435-6000

San Jose, CA
Tel: 408-735-9110

Canada - Toronto
Tel: 905-673-0699
Fax: 905-673-6509

ASIA/PACIFIC

Asia Pacific Office
Suites 3707-14, 37th Floor
Tower 6, The Gateway
Harbour City, Kowloon
Hong Kong
Tel: 852-2401-1200
Fax: 852-2401-3431

Australia - Sydney
Tel: 61-2-9868-6733
Fax: 61-2-9868-6755

China - Beijing
Tel: 86-10-8569-7000
Fax: 86-10-8528-2104

China - Chengdu
Tel: 86-28-8665-5511
Fax: 86-28-8665-7889

China - Chongqing
Tel: 86-23-8980-9588
Fax: 86-23-8980-9500

China - Hangzhou
Tel: 86-571-2819-3187
Fax: 86-571-2819-3189

China - Hong Kong SAR
Tel: 852-2943-5100
Fax: 852-2401-3431

China - Nanjing
Tel: 86-25-8473-2460
Fax: 86-25-8473-2470

China - Qingdao
Tel: 86-532-8502-7355
Fax: 86-532-8502-7205

China - Shanghai
Tel: 86-21-5407-5533
Fax: 86-21-5407-5066

China - Shenyang
Tel: 86-24-2334-2829
Fax: 86-24-2334-2393

China - Shenzhen
Tel: 86-755-8864-2200
Fax: 86-755-8203-1760

China - Wuhan
Tel: 86-27-5980-5300
Fax: 86-27-5980-5118

China - Xian
Tel: 86-29-8833-7252
Fax: 86-29-8833-7256

China - Xiamen
Tel: 86-592-2388138
Fax: 86-592-2388130

China - Zhuhai
Tel: 86-756-3210040
Fax: 86-756-3210049

ASIA/PACIFIC

India - Bangalore
Tel: 91-80-3090-4444
Fax: 91-80-3090-4123

India - New Delhi
Tel: 91-11-4160-8631
Fax: 91-11-4160-8632

India - Pune
Tel: 91-20-3019-1500

Japan - Osaka
Tel: 81-6-6152-7160
Fax: 81-6-6152-9310

Japan - Tokyo
Tel: 81-3-6880-3770
Fax: 81-3-6880-3771

Korea - Daegu
Tel: 82-53-744-4301
Fax: 82-53-744-4302

Korea - Seoul
Tel: 82-2-554-7200
Fax: 82-2-558-5932 or
82-2-558-5934

Malaysia - Kuala Lumpur
Tel: 60-3-6201-9857
Fax: 60-3-6201-9859

Malaysia - Penang
Tel: 60-4-227-8870
Fax: 60-4-227-4068

Philippines - Manila
Tel: 63-2-634-9065
Fax: 63-2-634-9069

Singapore
Tel: 65-6334-8870
Fax: 65-6334-8850

Taiwan - Hsin Chu
Tel: 886-3-5778-366
Fax: 886-3-5770-955

Taiwan - Kaohsiung
Tel: 886-7-213-7830

Taiwan - Taipei
Tel: 886-2-2508-8600
Fax: 886-2-2508-0102

Thailand - Bangkok
Tel: 66-2-694-1351
Fax: 66-2-694-1350

EUROPE

Austria - Wels
Tel: 43-7242-2244-39
Fax: 43-7242-2244-393

Denmark - Copenhagen
Tel: 45-4450-2828
Fax: 45-4485-2829

France - Paris
Tel: 33-1-69-53-63-20
Fax: 33-1-69-30-90-79

Germany - Dusseldorf
Tel: 49-2129-3766400

Germany - Munich
Tel: 49-89-627-144-0
Fax: 49-89-627-144-44

Germany - Pforzheim
Tel: 49-7231-424750

Italy - Milan
Tel: 39-0331-742611
Fax: 39-0331-466781

Italy - Venice
Tel: 39-049-7625286

Netherlands - Drunen
Tel: 31-416-690399
Fax: 31-416-690340

Poland - Warsaw
Tel: 48-22-3325737

Spain - Madrid
Tel: 34-91-708-08-90
Fax: 34-91-708-08-91

Sweden - Stockholm
Tel: 46-8-5090-4654

UK - Wokingham
Tel: 44-118-921-5800
Fax: 44-118-921-5820