



**BOURNS®**

**Features**

- No backlash - mounted directly to potentiometer shaft
- For use with precision potentiometers or other rotating devices up to 30 turns
- Compact size - requires only 25.4 mm diameter panel space
- Available with or without brake

**H-490 Turns-Counting Dial**

**Mechanical and Physical Characteristics**

Number of Turns .....	0 to 30
Dial Divisions .....	100 per turn
Readability - Over 10 Turns .....	1 part in 1000
Torque With Brake Engaged .....	350 g-cm (5 oz-in.) minimum
Markings .....	White on black background
Locking Brake.....	Refer to chart below
Weight .....	Approximately 7 grams (1/4 oz.)
Set Screws .....	UNC-3A 4-40, 2 screws 120° apart
Set Screw Tightening Torque .....	22.59 N-cm (2 lbs.-in.) minimum
Hex Key Size .....	0.05 in. hex

**Shaft and Bushing Requirements**

Shaft Diameter Requirements .....	Refer to chart below
Shaft Extension Beyond Panel .....	15.75 mm (0.62 in.) minimum
	21.21 mm (0.83 in.) maximum
Bushing Extension Beyond Panel .....	9.02 mm (0.35 in.) maximum

**H-490 MOUNTING INSTRUCTIONS**

1. Discard standard mounting nut and lockwasher supplied with the potentiometer; they will not be used.
2. Insert potentiometer in panel.
3. Using parts supplied with dial, position anti-rotation washer against panel. Tangs of washer should stick out from panel.
4. Install mounting nut supplied with dial. Be sure:
  - a. Shoulder on nut engages hold of anti rotation washer.
  - b. Tangs of anti-rotation washer are aligned vertically. This positions the turns-counting window properly.
5. Turn potentiometer shaft counterclockwise to minimum resistance or voltage ratio. This is not necessarily at the end of travel.
6. Loosen set screw in knob of dial assembly. Set dial to "0.00" reading. Slip dial assembly over end of potentiometer shaft.
7. Holding outer ring of dial assembly, engage locating tangs on anti-rotation washer in notches on dial assembly.
8. While holding outer ring, position unit lightly against panel. Uniformly tighten knob set screws to potentiometer shaft with furnished hex wrench.

**Dimensional Drawings**

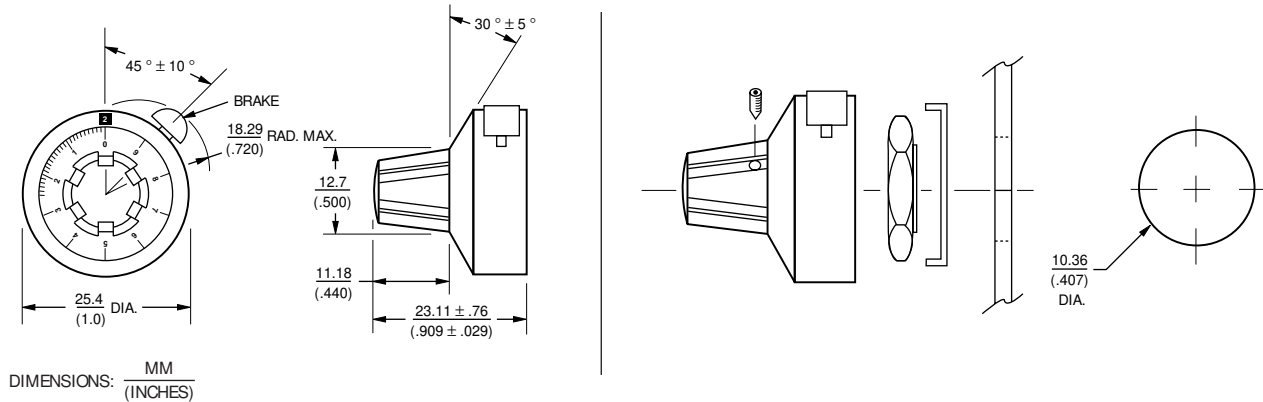

**How to Order**

Part Number	Accepts Shaft Diameter	Fits Bushing Size	Brake	Body Finish
H-493-2	3.18 mm (.125 in.)	6.35 mm-32UNEF-2A	No	Black
H-494-2	3.18 mm (.125 in.)	6.35 mm-32UNEF-2A	Yes	Black
H-491-3	6.35 mm (.250 in.)	9.53 mm-32UNEF-2A	No	Satin Chrome
H-492-3	6.35 mm (.250 in.)	9.53 mm-32UNEF-2A	Yes	Satin Chrome
H-493-3	6.35 mm (.250 in.)	9.53 mm-32UNEF-2A	No	Black
H-494-3	6.35 mm (.250 in.)	9.53 mm-32UNEF-2A	Yes	Black
H-492-2	3.18 mm (.125 in.)	6.35 mm-32UNEF-2A	Yes	Satin Chrome