

CoreLED P/N 12002-STAR-E17

- 2H x 2V Flood IES NEMA Type lens
- Nichia E17 LED source
- 20mm Starboard for easy prototyping and evaluation

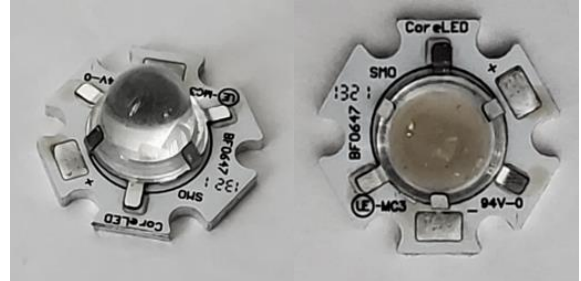

SMO Product Description:

The SMO product family is a series of molded high-temperature silicone miniature lenses that attach directly to PCB with solder clip using standard reflow method. These components achieve high light collection efficiency, a variety of engineered beam patterns, and are supplied for high volume pick and place electronics assembly.

Key Features:

- Optical lens is reflow mounted at the same time as LED assembly
- Supplied in tape and reel
- Increased control of light output
- Precision alignment (within ± 0.1 mm)
- Family of optical beam patterns that will work using IR reflow
- Reflow solder clip directly attached to lens
- Standard pick and place equipment
- Manufactured without the need for additional components to attach the optics

STARBOARD mounted optics are meant for PROTOTYPE and EVALUATION purposes only

Emitted Pattern Profile

Nichia E17 (Measured) 1717 LED package

IES NEMA Type	2H x 2V
Maximum Candela	1216
Horizontal Beam Angle (50%)	16.5
Vertical Beam Angle (50%)	16.5
Horizontal Field Angle (10%)	27.8
Vertical Field Angle (10%)	27.8
Total Lamp Lumens	100

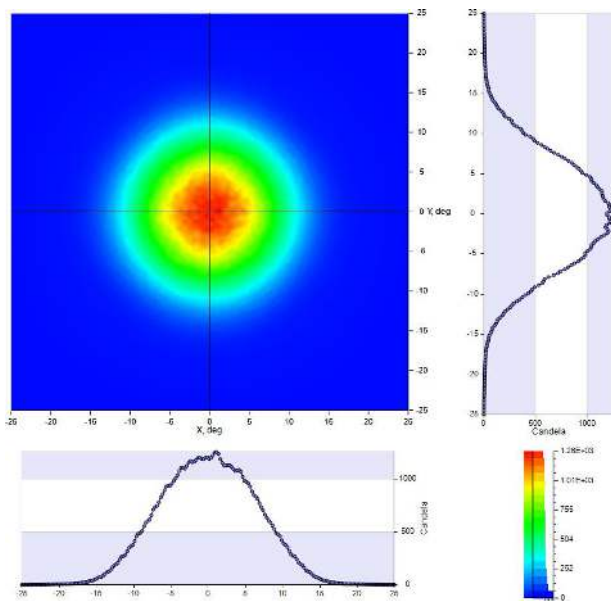

ANGULAR DISTRIBUTION OF LUMINOUS INTENSITY (cd)

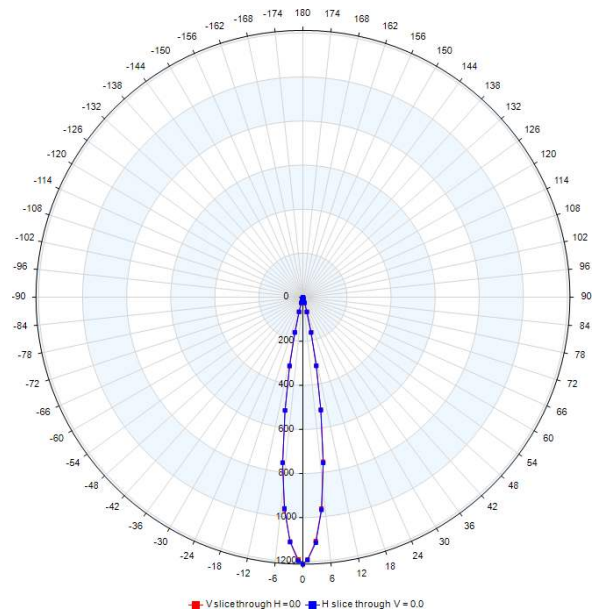

POLAR INTENSITY PLOT

IES files and Raytrace models are available upon request from CoreLed Engineering.

Mechanical Profile: SMO Bullet Collimator

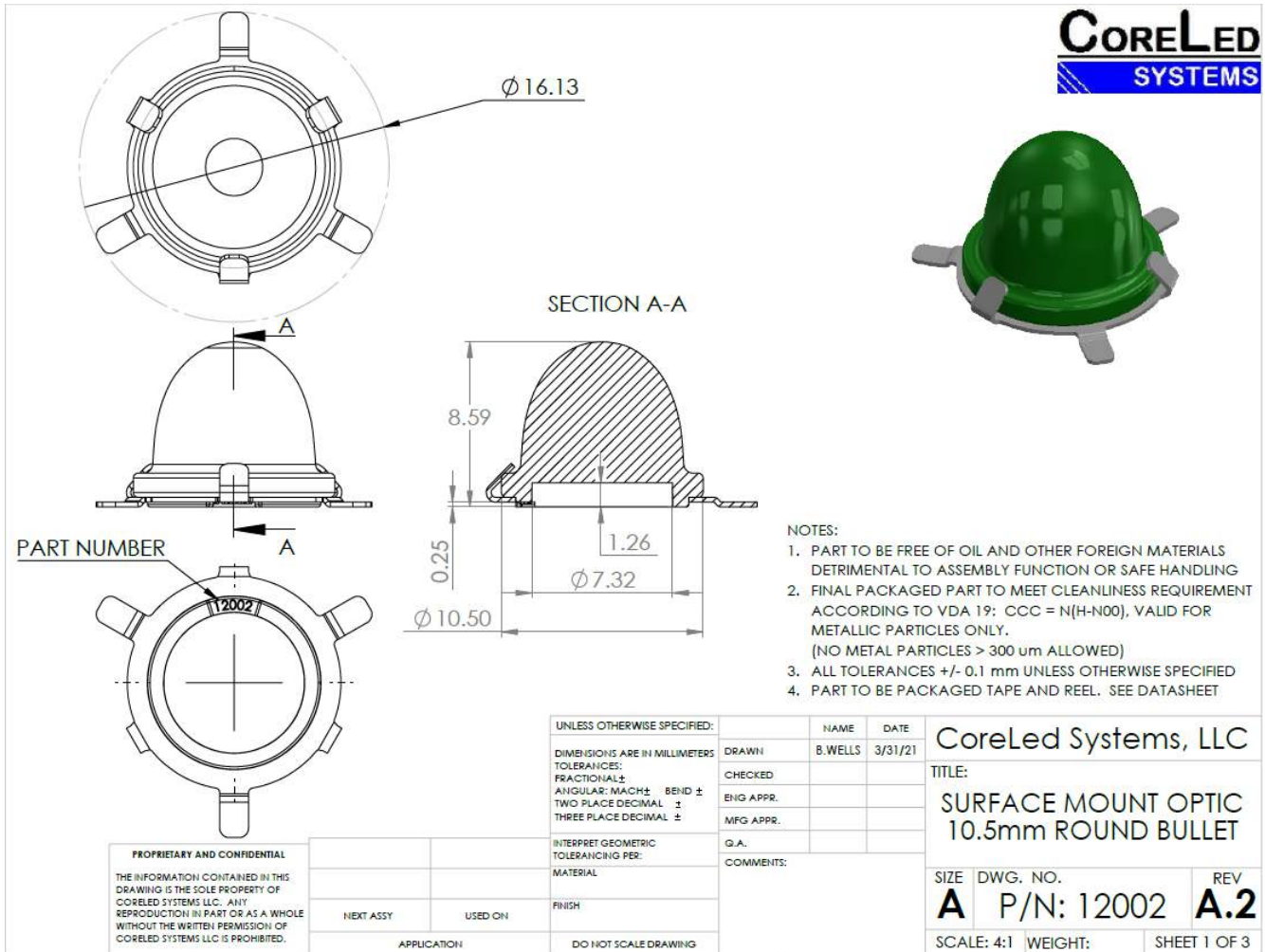

Mechanical design features shown with solder clip

CAD files available upon request from CoreLed Engineering

LED Information



NCSWE17AT

- Pb-free Reflow Soldering Application
- RoHS Compliant

NICHIA STS-DA1-3687I <Cat.No.170112>

SPECIFICATIONS

(1) Absolute Maximum Ratings

Item	Symbol	Absolute Maximum Rating	Unit
Forward Current	I_F	700	mA
Pulse Forward Current	I_{FP}	1000	mA
Reverse Voltage	V_R	5	V
Power Dissipation	P_D	2.31	W
Operating Temperature	T_{OP}	-40~100	°C
Storage Temperature	T_{STG}	-40~100	°C
Junction Temperature	T_J	135	°C

* Absolute Maximum Ratings at $T_C=25^\circ\text{C}$.

* I_{FP} conditions with pulse width $\leq 10\text{ms}$ and duty cycle $\leq 10\%$.

(2) Initial Electrical/Optical Characteristics

Item	Symbol	Condition	Typ	Max	Unit
Forward Voltage	V_F	$I_F=350\text{mA}$	3.0	-	V
Reverse Current	I_R	$V_R=5\text{V}$	-	-	μA
R70	Luminous Flux	Φ_v $I_F=350\text{mA}$	158	-	lm
	Color Rendering Index	R_a $I_F=350\text{mA}$	72	-	-
R8000	Luminous Flux	Φ_v $I_F=350\text{mA}$	148	-	lm
	Color Rendering Index	R_a $I_F=350\text{mA}$	82	-	-
R9050	Luminous Flux	Φ_v $I_F=350\text{mA}$	125	-	lm
	Color Rendering Index	R_a $I_F=350\text{mA}$	92	-	-
R9080	Luminous Flux	Φ_v $I_F=350\text{mA}$	118	-	lm
	Color Rendering Index	R_a $I_F=350\text{mA}$	92	-	-
Chromaticity Coordinate	x	- $I_F=350\text{mA}$	0.3447	-	-
	y	- $I_F=350\text{mA}$	0.3553	-	-
Thermal Resistance	$R_{\theta JC}$	-	0.5	1.0	°C/W

* Characteristics at $T_C=25^\circ\text{C}$.

* Luminous Flux value as per CIE 127:2007 standard.

* Chromaticity Coordinates as per CIE 1931 Chromaticity Chart.

* The thermal resistance value ($R_{\theta JC}$) is used to perform logical analysis (e.g. computer-based thermal analysis simulation) and represents a thermal resistance between the die to the T_C measurement point (PCB used: Aluminum PCB $t=1.5\text{mm}$, Insulating layer $t=0.12\text{mm}$).

* For more details on thermal resistance, see CAUTIONS, (6) Thermal Management.

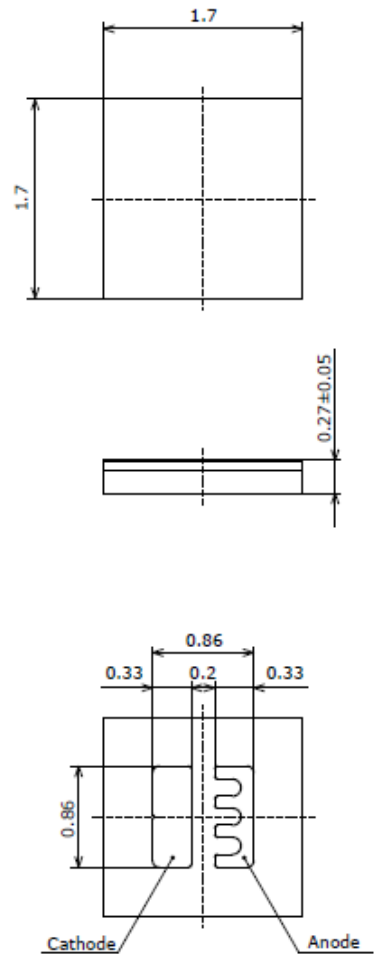

Starboard Schematic

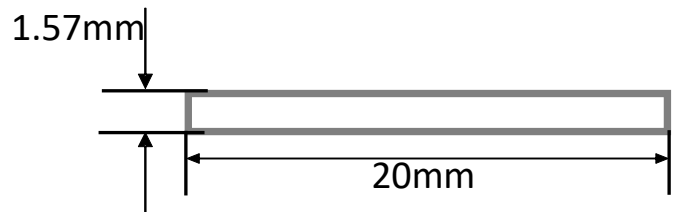
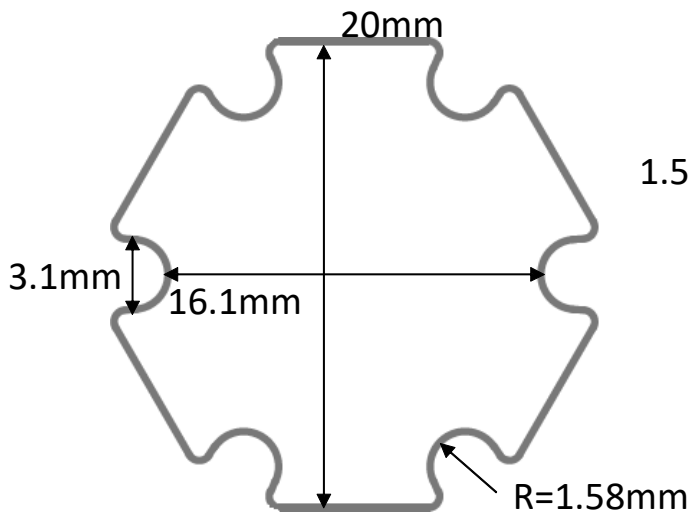
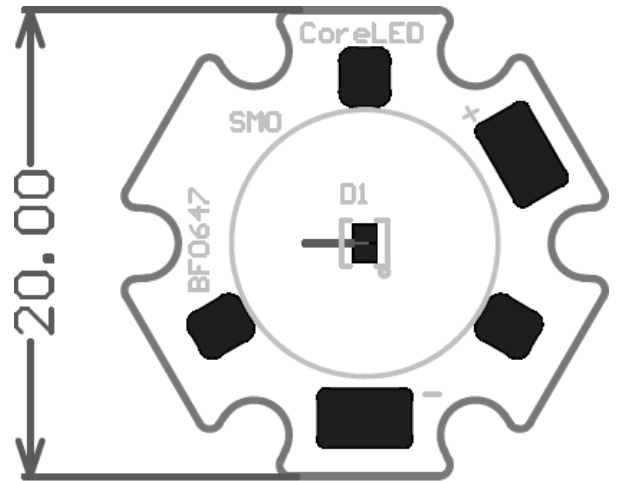
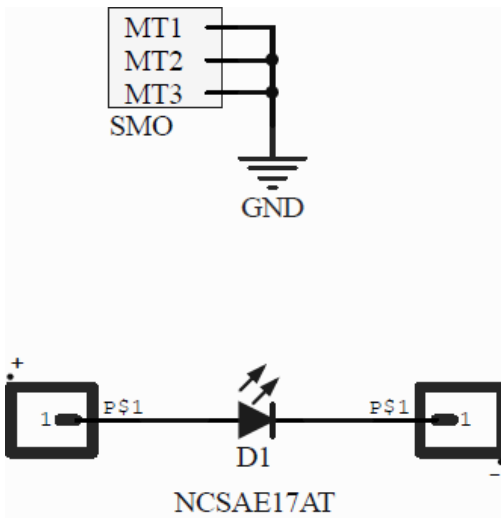

STARBOARD mounted optics are meant for PROTOTYPE and EVALUATION purposes only



Surface Mounted Optic (SMO)
10mm Round Bullet Collimator
STARBOARD
Rev 1.0 – 05/13/21

Electrical:

From LED Data sheet: recommended operation is Typical 3.0V at 350mA (1 Watt to provide 150 lumens).

Thermal:

Recommended attachment to heat sink to dissipate 1W (3.0V at 350mA). LED is rated higher and can be run up to 700mA with appropriate heatsinking provided.

Packaging:

Individually packaged in static controlled bag.

**STARBOARD mounted optics are meant for PROTOTYPE and
EVALUATION purposes only**