

LOC	DIST	REVISIONS			
P	LTN	DESCRIPTION	DATE	OWN	APVD
A		REVISED PER ECR-11-020171	03OCT2011	TD	TD

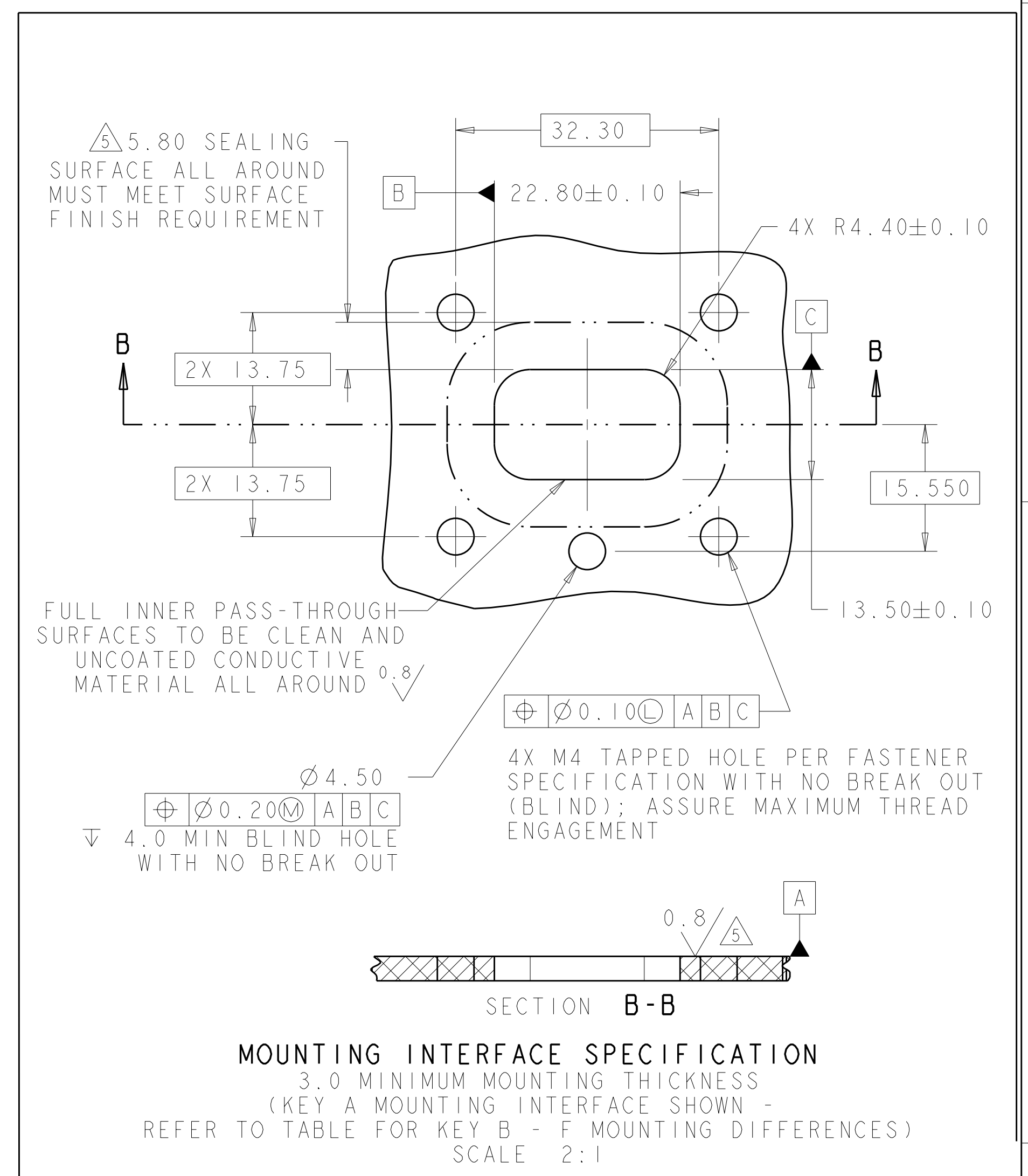
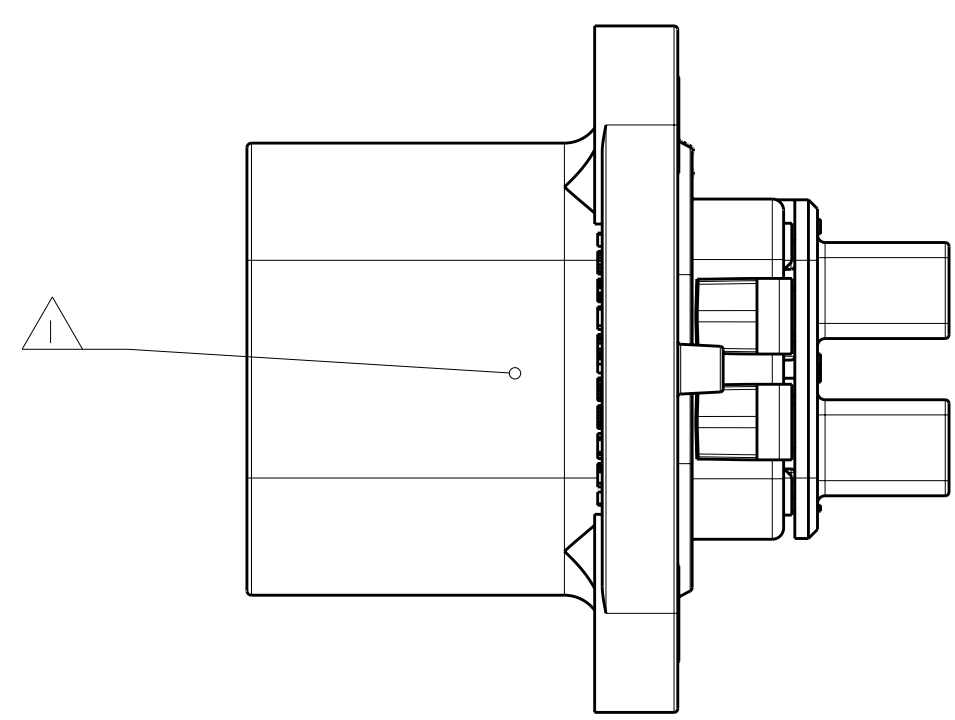
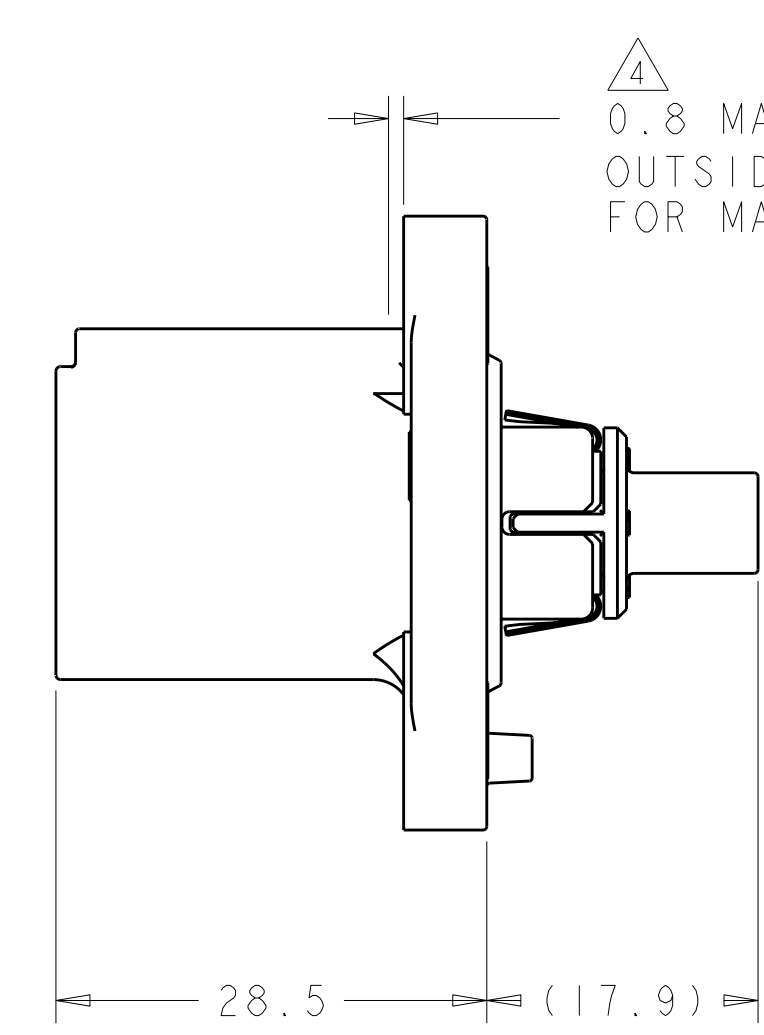
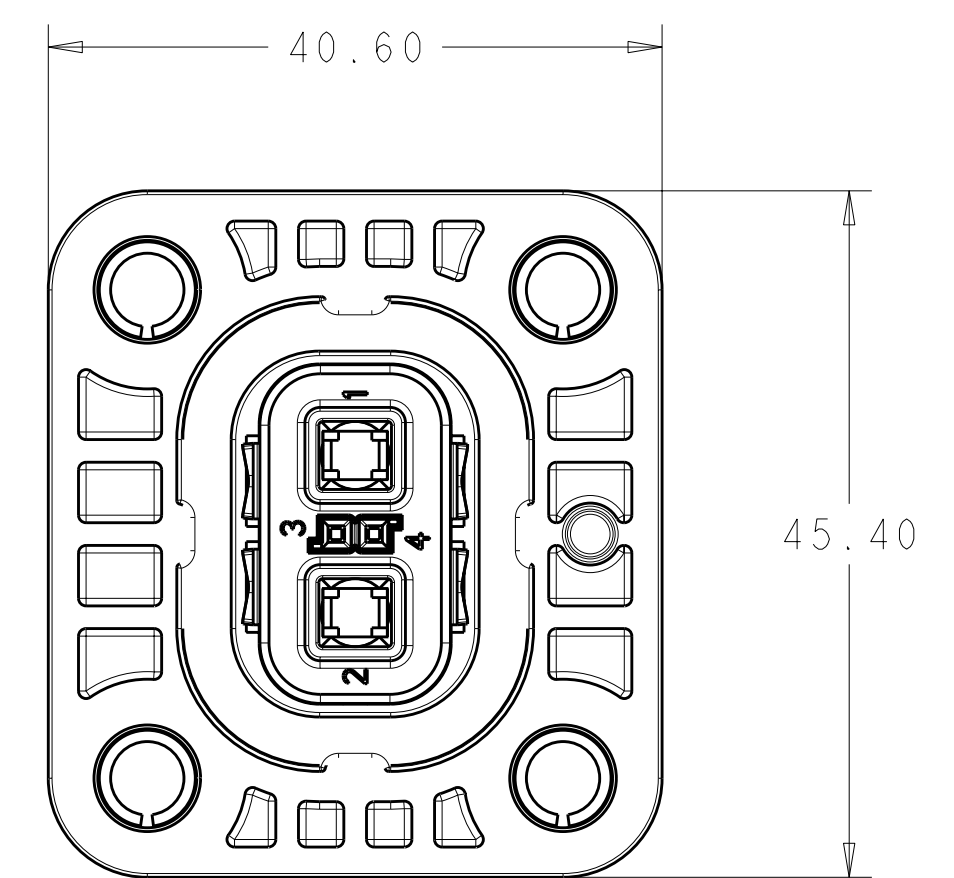
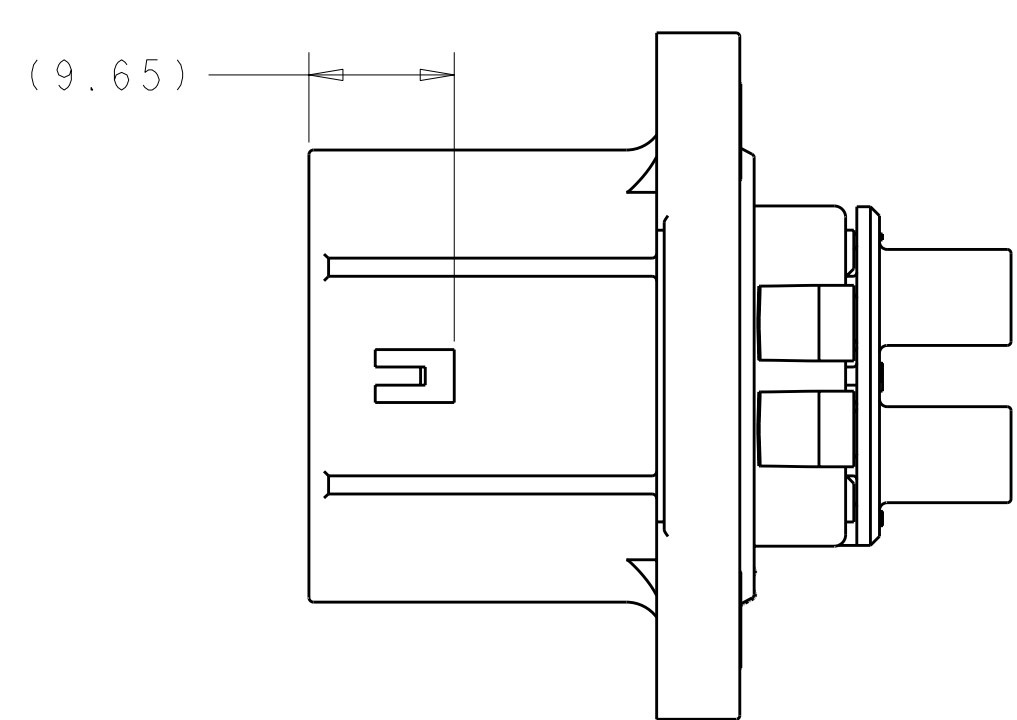
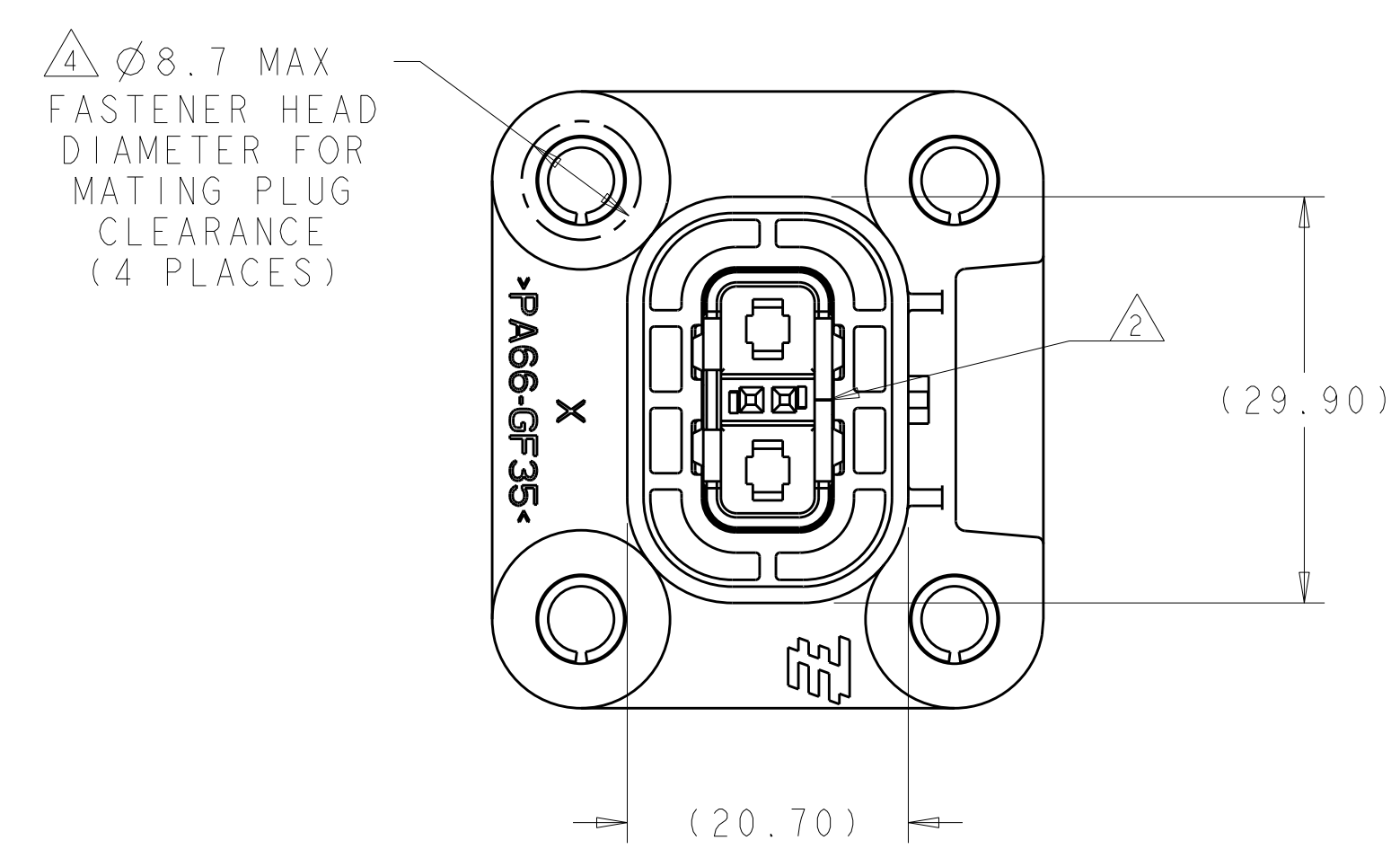
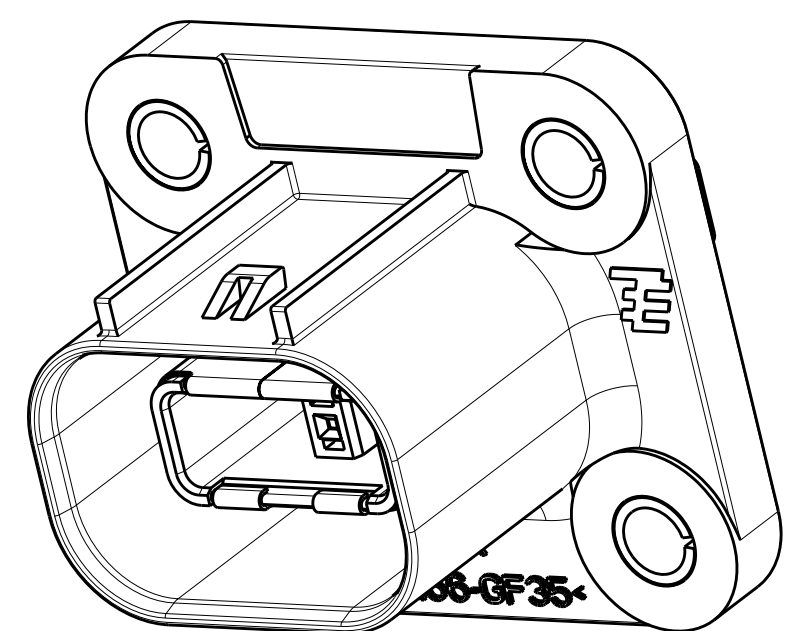

- 1 IDENTIFICATION MARKING ON THIS SURFACE CONTAINS ASSEMBLY P/N AND DATE CODE (YYDD). TEXT ORIENTATION, SIZE, AND LOCATION CAN VARY AS LONG AS TEXT IS ON SURFACE SHOWN AND READABLE.
- 2 SHIELD SEAM CAN BE POSITIONED AS SHOWN OR ROTATED 180° FROM POSITION SHOWN.
- 3 PRELIMINARY PART - NOT RELEASED FOR PRODUCTION
- 4 THESE DIMENSIONS DEFINE FASTENER SIZE LIMITS FOR PROPER COMPONENT FUNCTIONALITY. END USER MUST ENSURE FASTENER AND/OR WASHER DIAMETER IS 8.6 MM MIN FOR PROPER RETENTION. THESE ARE NOT PRODUCT FEATURES - NO INSPECTION REQUIRED FOR THESE ITEMS.
- 5 SURFACE FINISH APPLIES IN THIS AREA
- 6 REFER TO TE WORK INSTRUCTION 408-10294 FOR ASSEMBLY INSTRUCTIONS

INDEX	PART NO
F	1587975-6
E	1587975-5
D	1587975-4
B	1587975-2
A	1587975-1

DIMENSIONS: mm TOLERANCES UNLESS OTHERWISE SPECIFIED: 9 PLC ±0.50 1 PLC ±0.50 5 PLC ±0.15 4 PLC ±0.05 ANGLES ±0.5 FINISH		DWN T. DEWILTE 22JUL2009 CHK T. DEWILTE 16JUN2010 APVD T. DEWILTE 16JUN2010 NAME PRODUCT SPEC APPLICATION SPEC WEIGHT 23.5 g CUSTOMER DRAWING	Tyco Electronics Harrisburg, PA 17105-3608 HVA280 2P HEADER ASSY W/HVIL - PLASTIC CHART DRAWING SIZE CAGE CODE DRAWING NO A 100779 C=1587975 SCALE 2:1 SHEET 1 OF 2 REV A
---	--	--	--

LOC	DIST	REV	DATE	BY	APPD
HV	00				

REVISIONS		DATE	BY	APPD
1	SEE SHEET 1			

	1587975-1 (KEY A)	1587975-2 (KEY B)	1587975-4 (KEY D)	1587975-5 (KEY E)	1587975-6 (KEY F)
FRONT VIEW					
SIDE VIEW					
REAR VIEW					
INTERFACE VIEW - MOUNTING SIDE					
	KEY A MOUNTING INTERFACE	KEY B MOUNTING INTERFACE	KEY D MOUNTING INTERFACE	KEY E MOUNTING INTERFACE	KEY F MOUNTING INTERFACE

DIMENSIONS: mm 		TOLERANCES UNLESS OTHERWISE SPECIFIED: 9 PLC ±0.50 1 PLC ±0.50 5 PLC ±0.15 4 PLC ±0.05 ANGLES ±° FINISH ±#3		DWN T. DEWILITE 22JUL2009 CHK T. DEWILITE 16JUN2010 APVD T. DEWILITE 16JUN2010		Tyco Electronics Harrisburg, PA 17105-3608	
MATERIAL: - FINISH: -		WEIGHT: 23.5 g		NAME: HVA280 2P HEADER ASSY W/HVIL - PLASTIC CHART DRAWING		SIZE: A 00779 C=1587975 RESTRICTED TO: -	
CUSTOMER DRAWING				SCALE: 2:1		SHEET: 2 OF 2 REV: A	