

**FEATURES**

- LVPECL Outputs Optimized for Very Low Phase Noise (-165dBc/Hz)
- Up to 800MHz Bandwidth
- Selectable ÷1, ÷2 Output
- Selectable Enable Logic
- 3.0V to 3.6V Operation
- RoHS Compliant Pb Free Packages

**BLOCK DIAGRAM**

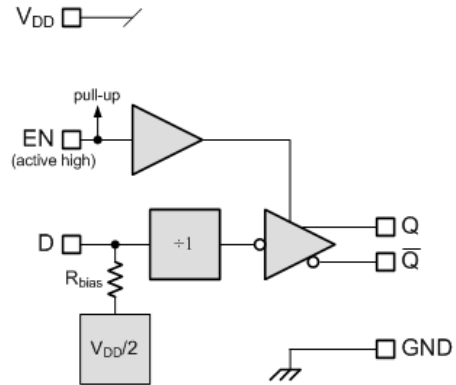

**DESCRIPTION**

The CTSLV351 is a sine wave/CMOS to LVPECL buffer & translator optimized for very low phase noise (-165dBc/Hz). It is particularly useful in converting crystal or SAW based oscillators into LVPECL outputs for up to 800MHz of bandwidth.

The CTSLV351 is one of a family of parts that provide options of fixed ÷1, fixed ÷2 and selectable ÷1, ÷2 modes as well as active high enable or active low enable to oscillator designers. Refer to Table 1 for the comparison of parts within the CTSLV35x and CTSLV363 family.

**ENGINEERING NOTES**

**Functionality**

Table 1 details the differences between the parts to assist designers in selecting the optimal part for their design.

Table 2 lists the specific CTSLV351 functional operation.

Figure 1 plots the S-parameters of the D input.

**Table 1**

Part Number	Divide Ratio	EN Logic	EN Pull-Up / Pull-Down	Bandwidth
CTSLV351	÷1	active HIGH	Pull-up	> 800MHz
CTSLV353	Selectable ÷1 or ÷2	selectable	selectable	> 800MHz
CTSLV363	Selectable ÷1 or ÷2	selectable	selectable	≥ 1GHz

**Table 2 - CTSLV351 Functional Operation, ±1 mode**

Part Number	Inputs		Outputs	
	EN_SEL	D	Q	$\bar{Q}$
CTSLV351	High, NC	Low	Low	High
		High	High	Low
	Low	X	Z	Z

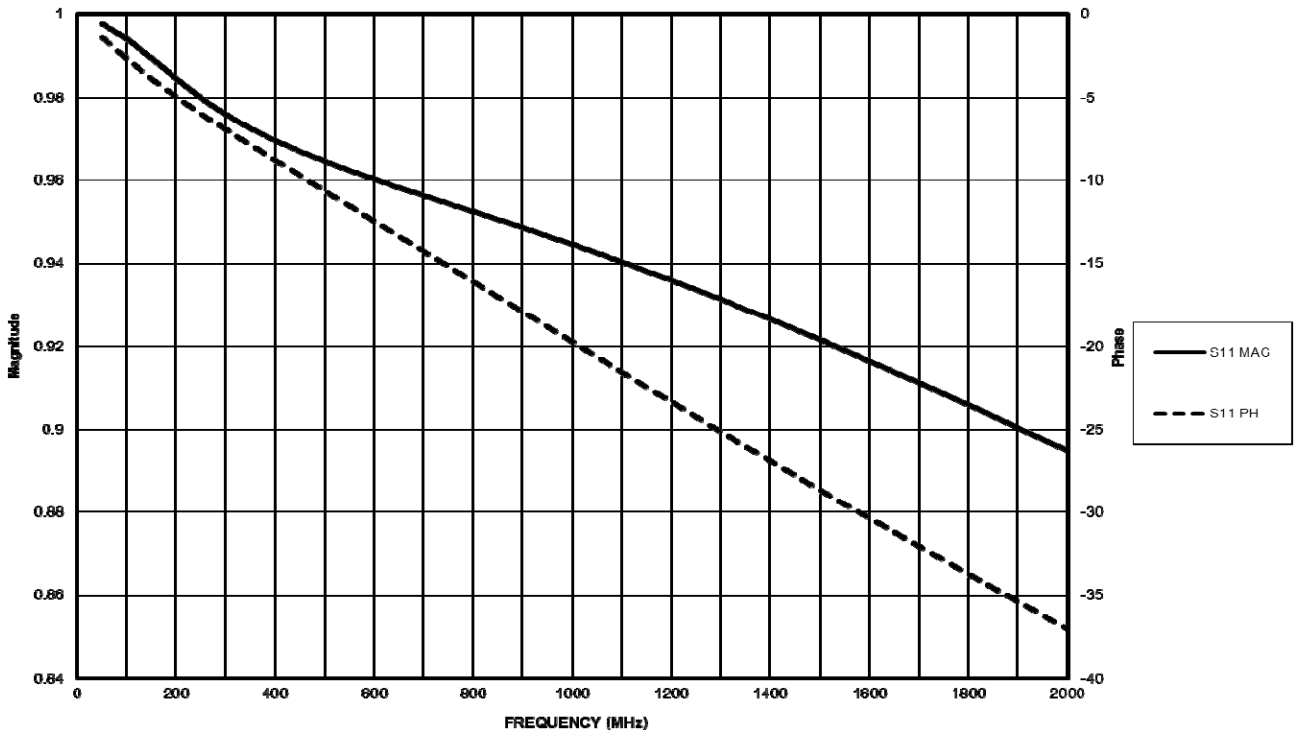

**Figure 1 - S11, Parameters, D Input**

**Input Termination**

The D input bias is  $V_{DD}/2$  fed through an internal  $10k\Omega$  resistor. For clock applications, an input signal of at least  $750mV_{PP}$  ensures the CTSLV351 meets AC specifications. The input should also be AC coupled to maintain a 50% duty cycle on the outputs. The input can be driven to any voltage between  $0V$  and  $V_{DD}$  without damage or waveform degradation.

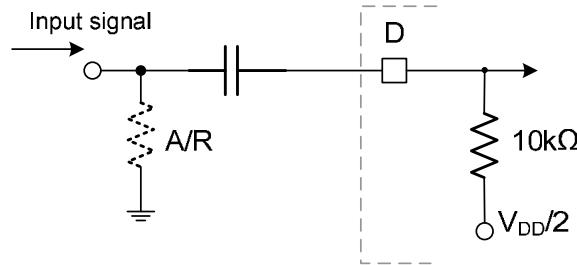
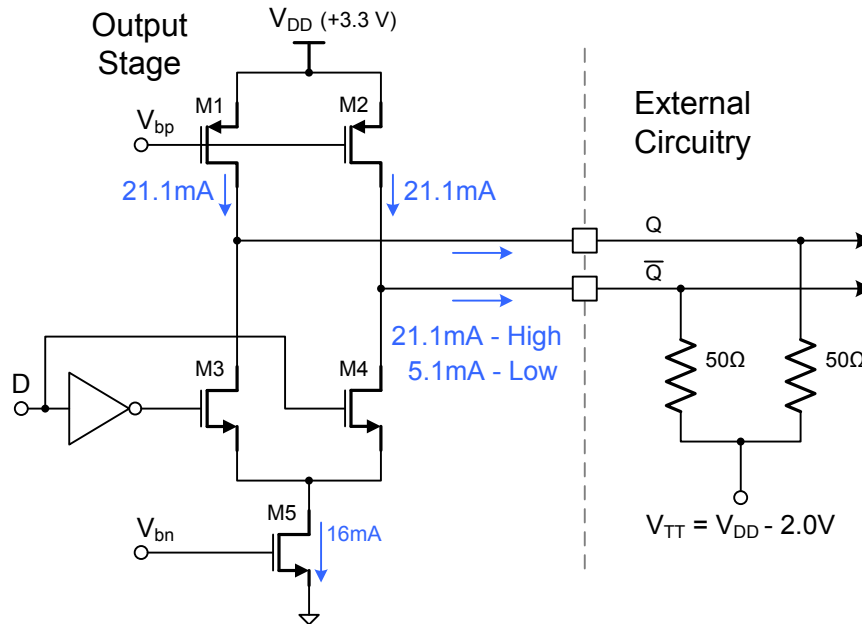

**Figure 2 - Input Termination**

**Output Termination Techniques**

The LVPECL compatible output stage of the CTSLV351 uses a current drive topology to maximize switching speed as illustrated below in Figure 3. Two current source PMOS transistors (M1-M2) feed the output pins. M5 is an NMOS current source which is switched by M3 and M4. When M4 is on, M5 takes current from M2. This produces an output current of  $5.1mA$  (low output state). M3 is off, and the entire  $21.1mA$  flows through the output pin. The associated output voltage swings match LVPECL levels when external  $50\Omega$  resistors terminate the outputs.

Both Q and  $\bar{Q}$  should always be terminated identically to avoid waveform distortion and circulating current caused by unsymmetrical loads. This rule should be followed even if only one output is in use.



**Figure 3 - Typical Output Termination**

**Dual Supply LVPECL Output Termination**

The standard LVPECL loads are a pair of 50Ω resistors connected between the outputs and V<sub>DD</sub>-2.0V (Figure 3). The resistors provide both the DC and the AC loads, assuming 50Ω interconnect. If an additional supply is available within the application, a four resistor termination configuration is possible (Figure 4).

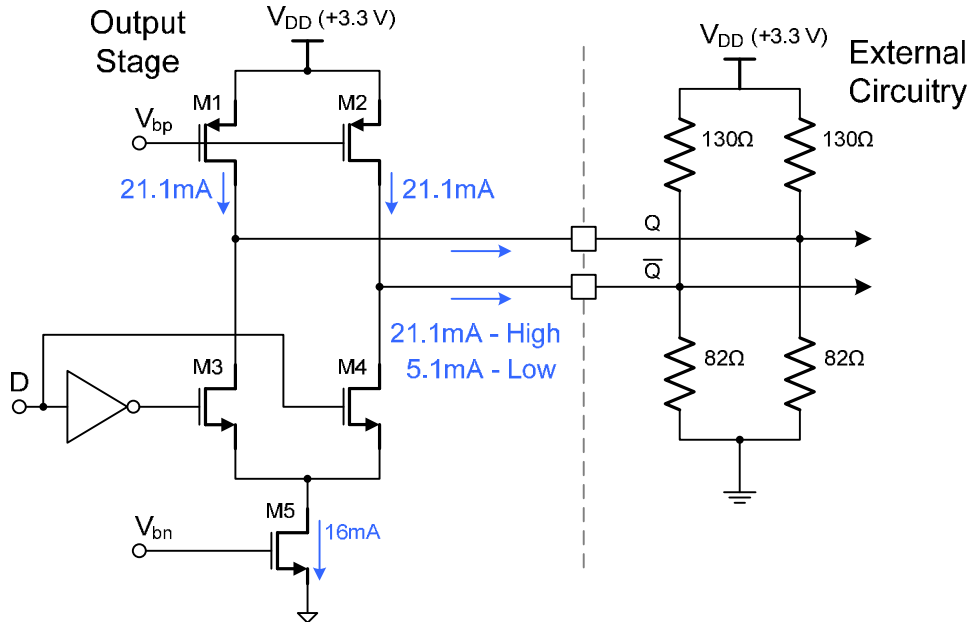

**Figure 4 - Dual Supply Output Termination**

**Three Resistor Termination**

Another termination variant eliminates the need for the additional supply (Figure 5). Alternately three resistors and one capacitor accomplish the same termination and reduce power consumption.

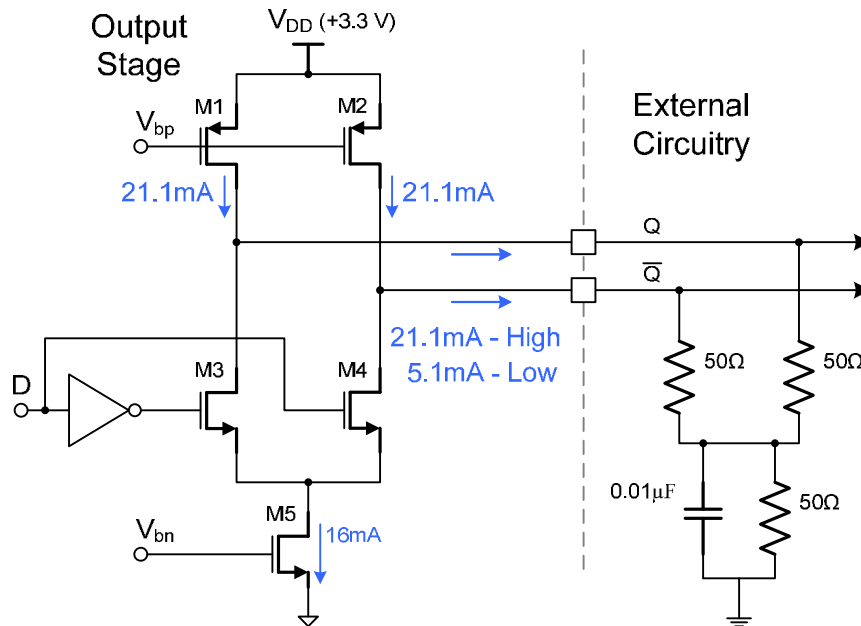

**Figure 5 - Three Resistor Termination**

**Evaluation Board (EBP53)**

CTS's evaluation board, EBP53, provides the most convenient way to test and prototype CTSLV351 series circuits. Built for the CTSLV353QG 1.5x1.0mm package, it is designed to support both dual and single supply operation. Dual supply operation ( $V_{DD}=+2.0V$ ,  $V_{SS}=-1.3V$ ) enables direct coupling to 50Ω time domain test equipment (Figure 6).

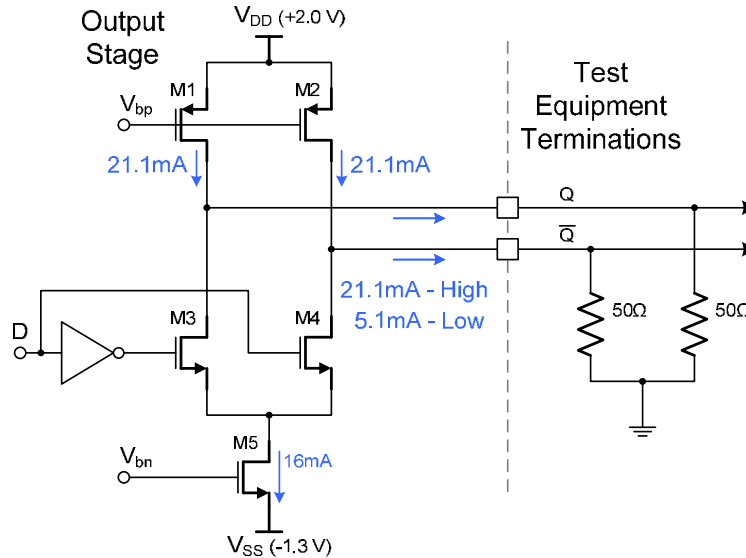

**Figure 6 - Split Supply LVPECL Output Termination**

**AC Termination**

Clock applications or phase noise/frequency domain testing scenarios typically require AC coupling. Figure 7 below shows the AC coupling technique. The 200Ω resistors form the required DC loads, and the 50Ω resistors provide the AC termination. The parallel combination of the 200Ω and 50Ω resistors results in a net 40Ω AC load termination. In many cases this will work well. If necessary, the 50Ω resistors can be increased to about 56Ω. Alternately, bias tees combined with current setting resistors will eliminate the lowered AC load impedance. The 50Ω resistors are typically connected to ground but can be connected to the bias level needed by the succeeding stage.

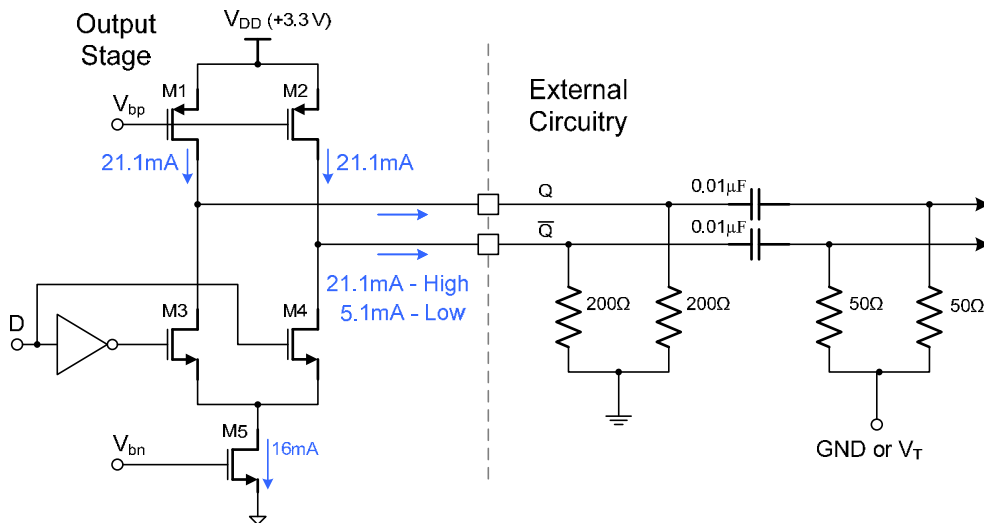

**Figure 7 - AC Termination**

## ELECTRICAL SPECIFICATIONS

### Absolute Maximum Ratings

Absolute Maximum Ratings are those values beyond which device life may be impaired.

Symbol	Characteristic	Rating	Unit
$V_{DD}$	Power Supply	0 to +5.5	V
$V_I$	Input Voltage	-0.5 to $V_{DD} + 0.5$	V
$T_A$	Operating Temperature Range	-40 to +85	°C
$T_{STG}$	Storage Temperature Range	-65 to +150	°C
$ESD_{HBM}$	Human Body Model	2500	V
$ESD_{MM}$	Machine Model	200	V
$ESD_{CDM}$	Charged Device Model	2500	V

### DC Characteristics

DC Characteristics ( $V_{DD} = 3.0V$  to  $3.6V$  unless otherwise specified,  $T_A = -40^{\circ}C$  to  $+85^{\circ}C$ )

Symbol	Characteristic	Conditions	Min	Typ	Max	Unit
$V_{OH}$	Output HIGH Voltage	-40°C	2.05		2.415	V
		+25°C				
		+85°C				
$V_{OL}$	Output LOW Voltage	-40°C	1.365		1.615	V
		+25°C				
		+85°C				
$I_Z$	Output Leakage Current, Tri-state	EN=Disable	-10		10	μA
$V_{IH}$	High Level Input Voltage	EN	2			V
$V_{IL}$	Low Level Input Voltage	EN			0.8	V
$I_{PD}$	Pull-down Current	EN		-2.2		μA
$R_{BIAS}$	Bias Resistor	D Input to Internal $V_{DD}/2$ Reference		10k		Ω
$I_{DD}$	Power Supply Current			22	35	mA
$I_{DDZ}$	Power Supply Current	D Input $\leq V_{IL}$			8	mA
	Outputs Tri-state	EN=Disable				

### AC Characteristics

#### AC Characteristics ( $V_{DD} = 3.0V$ to $3.6V$ , $T_A = -40^{\circ}C$ to $+85^{\circ}C$ )

AC Specifications guaranteed by design

Symbol	Characteristic	Min	Typ	Max	Unit
$t_R / t_F$	Output Rise/Fall <sup>1, 2</sup>	80		250	ps
	(20% - 80%)				
$f_{MAX}$	Maximum Input Frequency - Sine wave <sup>2</sup>			800	MHz
$V_{INMAX}$	Maximum Recommended Input Signal			$V_{DD}$	$V_{PP}$
$V_{INMIN}$	Minimum Recommended Input Signal	0.2			$V_{PP}$
$t_{PLH}$	Propagation Delay	938		1614	ps
$t_{PHL}$	Propagation Delay	938		1614	ps
$j_{RMS}$	RMS Jitter: 12kHz - 20MHz, 155MHz Center Freq		36		fs
$n_P$	Phase Noise <sup>1, 2</sup> - 1MHz offset		-165		dBc/Hz

## Pin Description and Configuration

### Pin Assignments

Pin	Name	Type	Function
1	V <sub>DD</sub>	Power	Positive Supply
2	GND	Power	Negative Supply
3	D	Input	Sine or CMOS Input
4	EN	Input	Enable
5	$\overline{Q}$	Input	Sine or CMOS Input
6	Q	Output	LVPECL Output

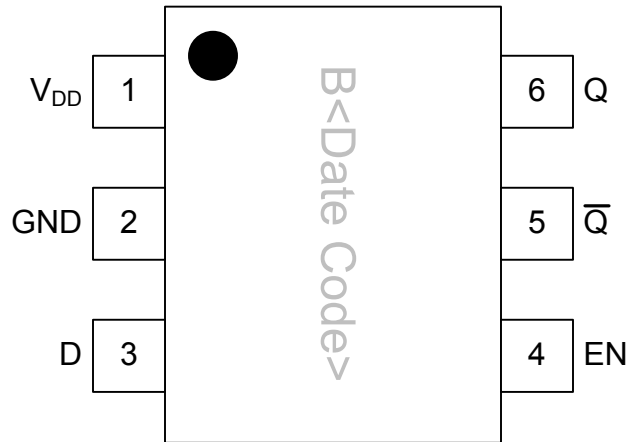

### PART ORDERING INFORMATION

Part Number	Package	Marking
CTSLV351SG	SC70-6	D1 YW



**PACKAGE DIMENSIONS**

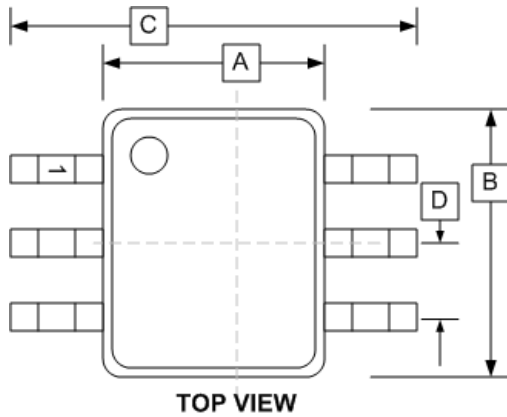

TOP VIEW

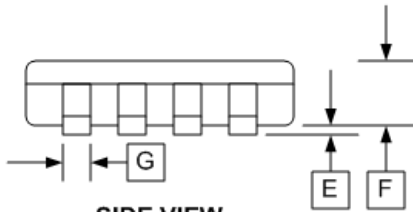

SIDE VIEW

MILLIMETERS		
DIM	MIN	MAX
A	1.15	1.35
B	1.85	2.25
C	2.00	2.30
D	0.65 BSC	
E	0.00	0.09
F	0.80	0.91
G	0.15	0.30
H	2.467	
I	0.08	0.25
J	0.21	0.41

**SC70-6 (S)**

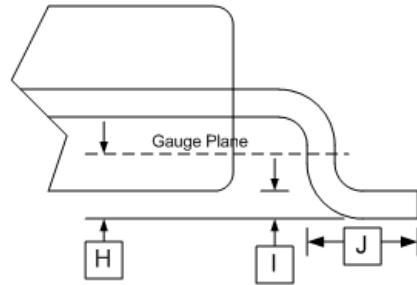

**PCB LAND PATTERN/FOOTPRINT**

Dimensions in mm

