

# DAC715

## 16-BIT DIGITAL-TO-ANALOG CONVERTER with 16-Bit Bus Interface

### FEATURES

- HIGH-SPEED 16-BIT PARALLEL DOUBLE-BUFFERED INTERFACE
- VOLTAGE OUTPUT: 0 to +10V
- 13-, 14-, 15-BIT LINEARITY GRADES
- 16-BIT MONOTONIC OVER TEMPERATURE (L GRADE)
- POWER DISSIPATION: 600mW max
- GAIN AND OFFSET ADJUST: Convenient for Auto-Cal D/A Converters
- 28-LEAD DIP AND SOIC PACKAGES

### DESCRIPTION

The DAC715 is a complete monolithic digital-to-analog converter including a +10V temperature compensated reference, current-to-voltage amplifier, 16-bit parallel interface that is double buffered, and an asynchronous clear function which immediately sets the output voltage to one-half of full-scale.

The output voltage range is 0 to +10V while operating from  $\pm 12V$  or  $\pm 15V$  supplies. The gain and bipolar offset adjustments are designed so that they can be set via external potentiometers or external D/A converters. The output amplifier is protected against short circuit to ground.

The 28-pin DAC715 is available in a 0.3" plastic DIP and wide-body plastic SOIC package. The DAC715P, U, PB, and UB are specified over the  $-40^{\circ}C$  to  $+85^{\circ}C$  temperature range while the DAC715PK, UK, PL, and UL are specified over the  $0^{\circ}C$  to  $+70^{\circ}C$  range.

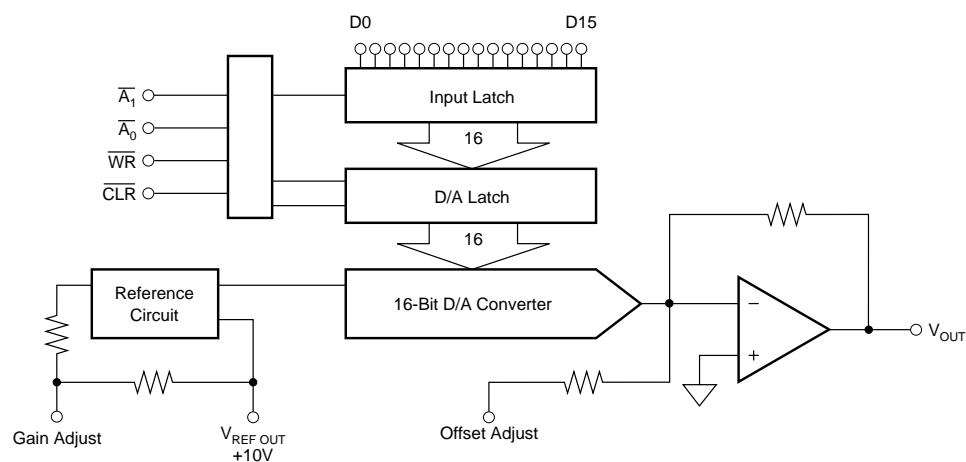

International Airport Industrial Park • Mailing Address: PO Box 11400, Tucson, AZ 85734 • Street Address: 6730 S. Tucson Blvd., Tucson, AZ 85706 • Tel: (520) 746-1111 • Twx: 910-952-1111  
Internet: <http://www.burr-brown.com/> • FAXLine: (800) 548-6133 (US/Canada Only) • Cable: BBRCORP • Telex: 066-6491 • FAX: (520) 889-1510 • Immediate Product Info: (800) 548-6132

# SPECIFICATIONS

## ELECTRICAL

At  $T_A = +25^\circ\text{C}$ ,  $V_{CC} = \pm 15\text{V}$ , and after a 10-minute warm-up, unless otherwise noted.

PARAMETER	DAC715P, U			DAC715PB, UB			DAC715PK, UK			DAC715PL, UL			UNITS
	MIN	TYP	MAX	MIN	TYP	MAX	MIN	TYP	MAX	MIN	TYP	MAX	
<b>INPUT</b>													
<b>RESOLUTION</b>			16			*			*			*	Bits
<b>DIGITAL INPUTS</b>													
Input Code	Binary Two's Complement				*			*		*			
Logic Levels <sup>(1)</sup> : $V_{IH}$	+2.0		$+V_{CC} - 1.4$	*		*	*	*	*	*	*	*	V
$V_{IL}$	0		+0.8	*		*	*	*	*	*	*	*	V
$I_{IH}$ ( $V_I = +2.7\text{V}$ )			$\pm 10$			*		*		*		*	$\mu\text{A}$
$I_{IL}$ ( $V_I = +0.4\text{V}$ )			$\pm 10$			*		*		*		*	$\mu\text{A}$
<b>TRANSFER CHARACTERISTICS</b>													
<b>ACCURACY</b>													
Linearity Error			$\pm 4$			$\pm 2$			$\pm 2$			$\pm 2$	LSB
$T_{MIN}$ to $T_{MAX}$			$\pm 8$			$\pm 4$			$\pm 2$			$\pm 2$	LSB
Differential Linearity Error			$\pm 4$			$\pm 2$			$\pm 2$			$\pm 1$	LSB
$T_{MIN}$ to $T_{MAX}$			$\pm 8$			$\pm 4$			$\pm 2$			$\pm 1$	LSB
Monotonicity Over Temp	13			14			15			16			Bits
Gain Error <sup>(3)</sup>			$\pm 0.1$			$\pm 0.1$			*			*	%
$T_{MIN}$ to $T_{MAX}$			$\pm 0.2$			$\pm 0.15$			*			*	%
Offset Error <sup>(3)</sup>			$\pm 0.1$			*			*			*	% FSR <sup>(2)</sup>
$T_{MIN}$ to $T_{MAX}$			$\pm 0.2$			*			*			*	% FSR
Power Supply Sensitivity Of Full Scale			$\pm 0.003$			*			*			*	% FSR/% $V_{CC}$
			$\pm 30$			*			*			*	PPM FSR/% $V_{CC}$
<b>DYNAMIC PERFORMANCE</b>													
Settling Time (to $\pm 0.003\%$ FSR, 5k $\Omega$    500pF Load) <sup>(4)</sup>													$\mu\text{s}$
10V Output Step		6	10		*	*		*	*		*	*	$\mu\text{s}$
1 LSB Output Step <sup>(5)</sup>		4			*			*			*		V/ $\mu\text{s}$
Output Slew Rate		10			*			*			*		%
Total Harmonic Distortion + Noise													%
0dB, 1001Hz, $f_s = 100\text{kHz}$		0.005			*			*			*		%
-20dB, 1001Hz, $f_s = 100\text{kHz}$		0.03			*			*			*		%
-60dB, 1001Hz, $f_s = 100\text{kHz}$		3.0			*			*			*		%
SINAD													dB
1001Hz, $f_s = 100\text{kHz}$		87			*			*			*		nV-s
Digital Feedthrough <sup>(5)</sup>		2			*			*			*		nV-s
Digital-to-Analog Glitch Impulse <sup>(5)</sup>		15			*			*			*		nV-s
Output Noise Voltage (includes Reference)		120			*			*			*		nV/ $\sqrt{\text{Hz}}$
<b>ANALOG OUTPUT</b>													
Output Voltage Range	0 to +10			*		*	*	*	*	*	*	*	V
$+V_{CC}$ , $-V_{CC} = \pm 11.4\text{V}$	$\pm 5$			*		*	*	*	*	*	*	*	mA
Output Current		0.1		*	*	*	*	*	*	*	*	*	$\Omega$
Output Impedance					*			*			*		
Short Circuit to ACOM Duration		Indefinite			*			*			*		
<b>REFERENCE VOLTAGE</b>													
Voltage	+9.975	+10.000	+10.025	*	*	*	*	*	*	*	*	*	V
$T_{MIN}$ to $T_{MAX}$	+9.960		+10.040	*	*	*	*	*	*	*	*	*	V
Output Resistance		1		*	*	*	*	*	*	*	*	*	$\Omega$
Source Current	2			*	*	*	*	*	*	*	*	*	mA
Short Circuit to ACOM, Duration		Indefinite			*			*			*		
<b>POWER SUPPLY REQUIREMENTS</b>													
Voltage: $+V_{CC}$	+11.4	+15	+16.5	*	*	*	*	*	*	*	*	*	V
$-V_{CC}$	-16.5	-15	-11.4	*	*	*	*	*	*	*	*	*	V
Current (no load, $\pm 15\text{V}$ Supplies)					*	*	*	*	*	*	*	*	mA
$+V_{CC}$		13	15		*	*		*	*		*	*	mA
$-V_{CC}$		22	25		*	*		*	*		*	*	mA
Power Dissipation		525	600		*	*		*	*		*	*	mW
<b>TEMPERATURE RANGE</b>													
Specification All Grades	-40		+85	*		*	0		+70	*		*	$^\circ\text{C}$
Storage	-60		+150	*		*	*		*	*		*	$^\circ\text{C}$
Thermal Resistance $\theta_{JA}$													$^\circ\text{C}/\text{W}$
DIP Package		75			*			*		*		*	$^\circ\text{C}/\text{W}$
SOIC Package		75			*			*		*		*	$^\circ\text{C}/\text{W}$

\* Specifications are the same as grade to the left.

NOTES: (1) Digital inputs are TTL and +5V CMOS compatible over the specification temperature range. (2) FSR means Full Scale Range. For example, for a 0 to +10V output, FSR = 10V. (3) Errors externally adjustable to zero. (4) Maximum represents greater than the 3 $\sigma$  limit. Not 100% tested for this parameter. (5) For the worst case code changes: FFFF<sub>H</sub> to 0000<sub>H</sub> and 0000<sub>H</sub> to FFFF<sub>H</sub>. These are Binary Two's Complement (BTC) codes. (6) Typical supply voltages times maximum currents.

## ABSOLUTE MAXIMUM RATINGS<sup>(1)</sup>

+V <sub>CC</sub> to COMMON .....	0V, +17V
-V <sub>CC</sub> to COMMON .....	0V, -17V
+V <sub>CC</sub> to -V <sub>CC</sub> .....	34V
Digital Inputs to COMMON .....	-1V to +V <sub>CC</sub>
External Voltage Applied to BPO and Range Resistors .....	±V <sub>CC</sub>
V <sub>REF OUT</sub> .....	Indefinite Short to COMMON
V <sub>OUT</sub> .....	Indefinite Short to COMMON
Power Dissipation .....	750mW
Storage Temperature .....	-60°C to +150°C
Lead Temperature (soldering, 10s) .....	+300°C

NOTE: (1) Stresses above those listed under "Absolute Maximum Ratings" may cause permanent damage to the device. Exposure to absolute maximum conditions for extended periods may affect device reliability.

## PACKAGE INFORMATION

PRODUCT	PACKAGE	PACKAGE DRAWING NUMBER <sup>(1)</sup>
DAC715P	Plastic DIP	246
DAC715U	Plastic SOIC	217
DAC715PB	Plastic DIP	246
DAC715UB	Plastic SOIC	217
DAC715PK	Plastic DIP	246
DAC715UK	Plastic SOIC	217
DAC715PL	Plastic DIP	246
DAC715UL	Plastic SOIC	217

NOTE: (1) For detailed drawing and dimension table, please see end of data sheet, or Appendix C of Burr-Brown IC Data Book.

## ORDERING INFORMATION

PRODUCT	PACKAGE	TEMPERATURE RANGE	DIFFERENTIAL LINEARITY ERROR MAX at +25°C
DAC715P	Plastic DIP	-40°C to +85°C	±4LSB
DAC715U	Plastic SOIC	-40°C to +85°C	±4LSB
DAC715PB	Plastic DIP	-40°C to +85°C	±2LSB
DAC715UB	Plastic SOIC	-40°C to +85°C	±2LSB
DAC715PK	Plastic DIP	0°C to 70°C	±2LSB
DAC715UK	Plastic SOIC	0°C to 70°C	±2LSB
DAC715PL	Plastic DIP	0°C to 70°C	±1LSB
DAC715UL	Plastic SOIC	0°C to 70°C	±1LSB

## TIMING DIAGRAM

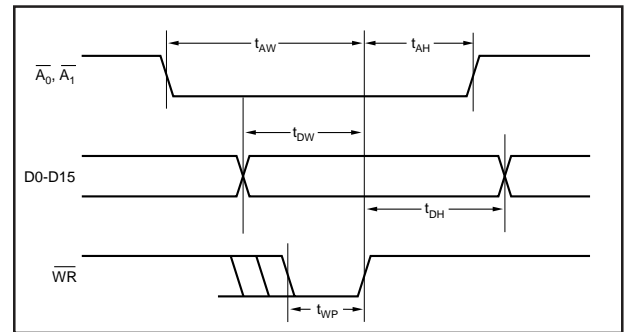

## TIMING SPECIFICATIONS

T<sub>A</sub> = -40°C to +85°C, +V<sub>CC</sub> = +12V or +15V, -V<sub>CC</sub> = -12V or -15V.

SYMBOL	PARAMETER	MIN	MAX	UNITS
t <sub>DW</sub>	Data Valid to End of $\overline{WR}$	50		ns
t <sub>AW</sub>	$\overline{A_0}, \overline{A_1}$ Valid to End of $\overline{WR}$	50		ns
t <sub>AH</sub>	$\overline{A_0}, \overline{A_1}$ Hold after End of $\overline{WR}$	10		ns
t <sub>DH</sub>	Data Hold after end of $\overline{WR}$	10		ns
t <sub>WP</sub> <sup>(1)</sup>	Write Pulse Width	50		ns
t <sub>CP</sub>	CLEAR Pulse Width	200		ns

NOTES: (1) For single-buffered operation, t<sub>WP</sub> is 80ns min. Refer to page 10.

## TRUTH TABLE

$\overline{A_0}$	$\overline{A_1}$	$\overline{WR}$	$\overline{CLR}$	DESCRIPTION
0	1	1 → 0 → 1	1	Load Input Latch
1	0	1 → 0 → 1	1	Load D/A Latch
1	1	1 → 0 → 1	1	No Change
0	0	0	1	Latches Transparent
X	X	1	1	No Change
X	X	X	0	Reset D/A Latch

## ELECTROSTATIC DISCHARGE SENSITIVITY

Electrostatic discharge can cause damage ranging from performance degradation to complete device failure. Burr-Brown Corporation recommends that all integrated circuits be handled and stored using appropriate ESD protection methods.

ESD damage can range from subtle performance degradation to complete device failure. Precision integrated circuits may be more susceptible to damage because very small parametric changes could cause the device not to meet published specifications.

The information provided herein is believed to be reliable; however, BURR-BROWN assumes no responsibility for inaccuracies or omissions. BURR-BROWN assumes no responsibility for the use of this information, and all use of such information shall be entirely at the user's own risk. Prices and specifications are subject to change without notice. No patent rights or licenses to any of the circuits described herein are implied or granted to any third party. BURR-BROWN does not authorize or warrant any BURR-BROWN product for use in life support devices and/or systems.

## PIN CONFIGURATION

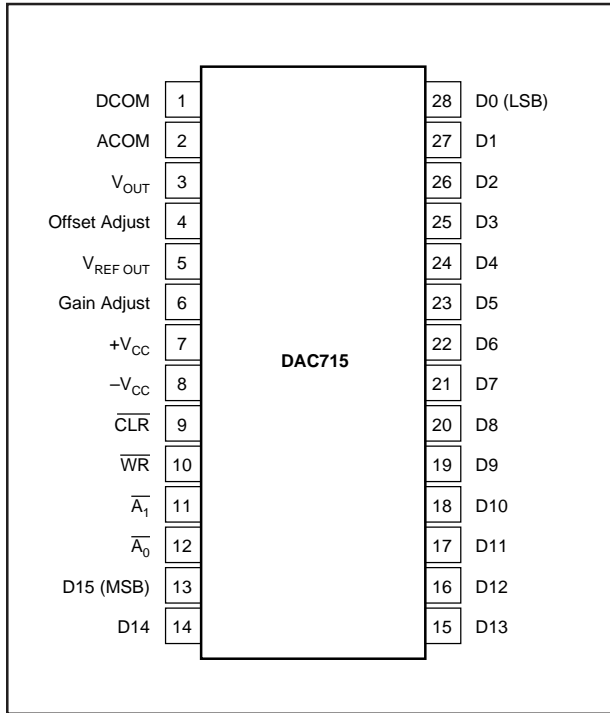

## PIN DESCRIPTIONS

PIN	LABEL	DESCRIPTION
1	DCOM	Digital Ground
2	ACOM	Analog Ground
3	$V_{OUT}$	0 to +10V D/A Output
4	Offset Adjust	Offset Adjust
5	$V_{REF OUT}$	Voltage Reference Output
6	Gain Adjust	Gain Adjust
7	$+V_{CC}$	+12V to +15V Supply
8	$-V_{CC}$	-12V to -15V Supply
9	$\overline{CLR}$	CLEAR. Sets D/A output to Half Scale (Active Low)
10	$\overline{WR}$	Write (Active Low)
11	$\overline{A}_1$	Enable for D/A latch (Active Low)
12	$\overline{A}_0$	Enable for Input latch (Active Low)
13	D15	Data Bit 15 (Most Significant Bit)
14	D14	Data Bit 14
15	D13	Data Bit 13
16	D12	Data Bit 12
17	D11	Data Bit 11
18	D10	Data Bit 10
19	D9	Data Bit 9
20	D8	Data Bit 8
21	D7	Data Bit 7
22	D6	Data Bit 6
23	D5	Data Bit 5
24	D4	Data Bit 4
25	D3	Data Bit 3
26	D2	Data Bit 2
27	D1	Data Bit 1
28	D0	Data Bit 0 (Least Significant Bit)

# TYPICAL PERFORMANCE CURVES

At  $T_A = +25^\circ\text{C}$ , and  $V_{CC} = \pm 15\text{V}$ , unless otherwise noted.

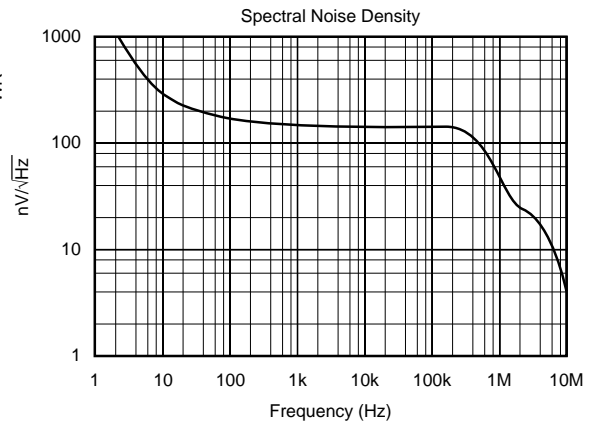
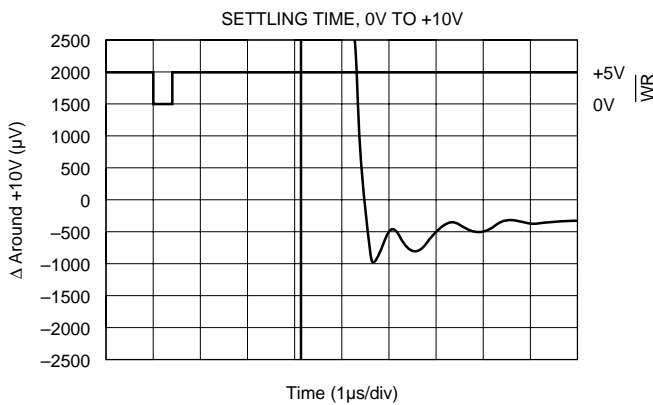
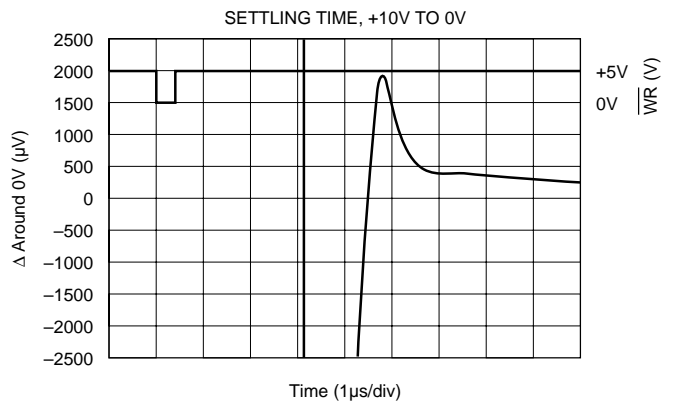
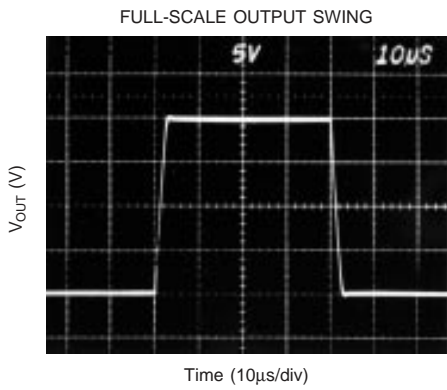
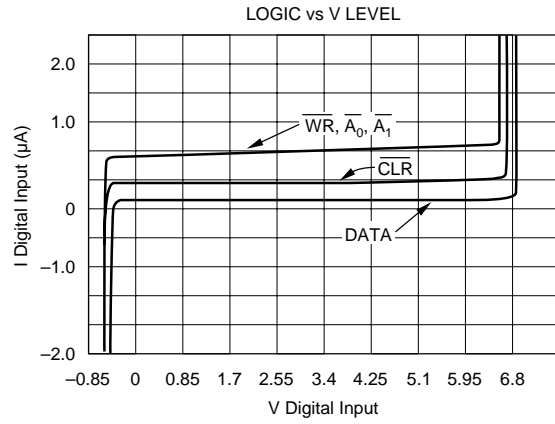
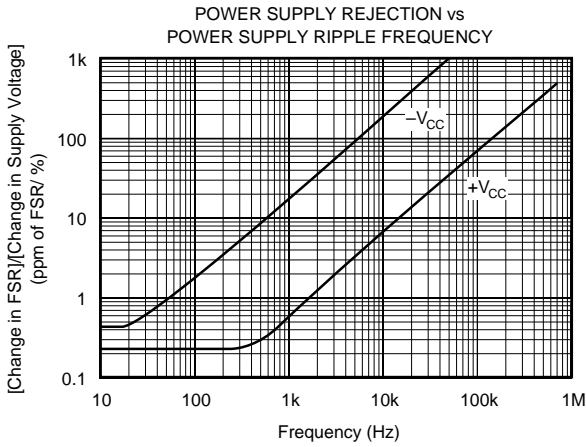

# DISCUSSION OF SPECIFICATIONS

## LINEARITY ERROR

Linearity error is defined as the deviation of the analog output from a straight line drawn between the end points of the transfer characteristic.

## DIFFERENTIAL LINEARITY ERROR

Differential linearity error (DLE) is the deviation from 1LSB of an output change from one adjacent state to the next. A DLE specification of  $\pm 1/2\text{LSB}$  means that the output step size can range from  $1/2\text{LSB}$  to  $3/2\text{LSB}$  when the digital input code changes from one code word to the adjacent code word. If the DLE is more positive than  $-1\text{LSB}$ , the D/A is said to be monotonic.

## MONOTONICITY

A D/A converter is monotonic if the output either increases or remains the same for increasing digital input values. Monotonicity of DAC715 is guaranteed over the specification temperature range to 13-, 14-, 15-, and 16-bits for performance grades DAC715P/U, DAC715PB/UB, DAC715PK/UK, and DAC715PL/UL respectively.

## SETTLING TIME

Settling time is the total time (including slew time) for the D/A output to settle to within an error band around its final value after a change in input. Settling times are specified to within  $\pm 0.003\%$  of Full Scale Range (FSR) for an output step change of 10V and 1LSB. The 1LSB change is measured at the Major Carry ( $\text{FFFF}_{\text{H}}$  to  $0000_{\text{H}}$ , and  $0000_{\text{H}}$  to  $\text{FFFF}_{\text{H}}$ ; BTC codes), the input transition at which worst-case settling time occurs.

## TOTAL HARMONIC DISTORTION

Total harmonic distortion is defined as the ratio of the square root of the sum of the squares of the values of the harmonics to the value of the fundamental frequency. It is expressed in % of the fundamental frequency amplitude at sampling rate  $f_s$ .

## SIGNAL-TO-NOISE AND DISTORTION RATIO (SINAD)

SINAD includes all the harmonic and outstanding spurious components in the definition of output noise power in addition to quantizing and internal random noise power. SINAD is expressed in dB at a specified input frequency and sampling rate,  $f_s$ .

## DIGITAL-TO-ANALOG GLITCH IMPULSE

The amount of charge injected into the analog output from the digital inputs when the inputs change state. It is measured at half scale at the input codes where as many as possible switches change state—from  $\text{FFFF}_{\text{H}}$  to  $0000_{\text{H}}$ .

## DIGITAL FEEDTHROUGH

When the D/A is not selected, high frequency logic activity on the digital inputs is coupled through the device and shows up as output noise. This noise is digital feedthrough.

## OPERATION

The DAC715 is a monolithic integrated-circuit 16-bit D/A converter complete with 16-bit D/A switches and ladder network, voltage reference, output amplifier and microprocessor bus interface.

## INTERFACE LOGIC

The DAC715 has double-buffered data latches. The input data latch holds a 16-bit data word before loading it into the second latch, the D/A latch. This double-buffered organization permits simultaneous update of several D/A converters. All digital control inputs are active low. Refer to the block diagram shown in Figure 1.

All latches are level-triggered. Data present when the enable inputs are logic "0" will enter the latch. When the enable inputs return to logic "1", the data is latched.

The CLR input resets both the input latch and the D/A latch to give a half scale output.

## LOGIC INPUT COMPATIBILITY

The DAC715 digital inputs are TTL compatible (1.4V switching level), low leakage, and high impedance. Thus the inputs are suitable for being driven by any type of 5V logic family, such as CMOS logic. An equivalent circuit for the digital inputs is shown in Figure 2.

The inputs will float to logic "0" if left unconnected. It is recommended that any unused inputs be connected to DCOM to improve noise immunity.

Digital inputs remain high impedance when power is off.

## INPUT CODING

The DAC715 is designed to accept binary two's complement (BTC) input codes. For unipolar analog output configuration, a digital input of  $7\text{FFF}_{\text{H}}$  gives a full scale output,  $8000_{\text{H}}$  gives a zero output, and  $0000_{\text{H}}$  gives half scale output.

## INTERNAL REFERENCE

The DAC715 contains a +10V reference. The reference output may be used to drive external loads, sourcing up to 2mA. The load current should be constant, otherwise the gain of the converter will vary.

## OUTPUT VOLTAGE SWING

The output amplifier of the DAC715 is committed to a 0 to +10V output range. It will provide a 0 to +10V output swing while operating on  $\pm 11.4\text{V}$  or higher voltage supplies.

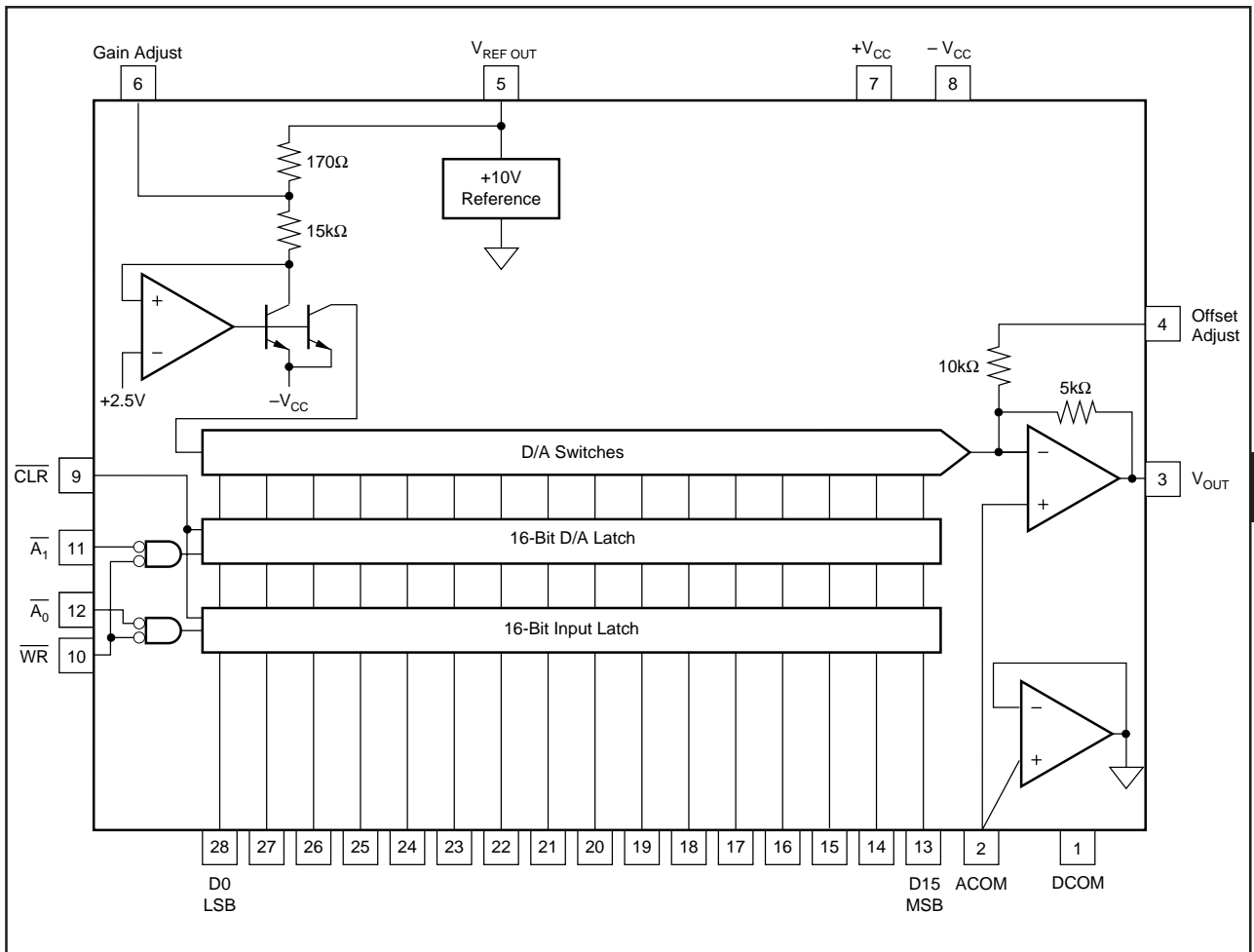

FIGURE 1. DAC715 Block Diagram.

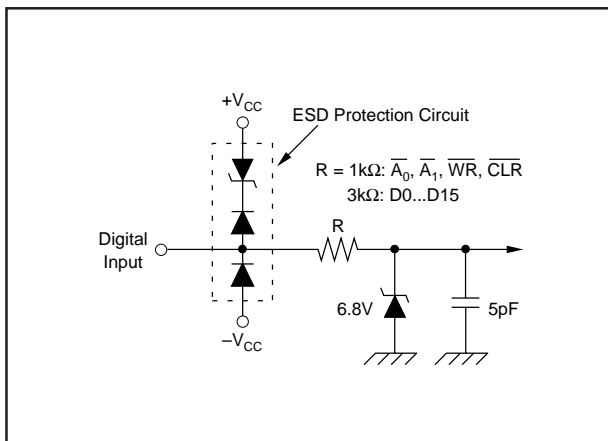

FIGURE 2. Equivalent Circuit of Digital Inputs.

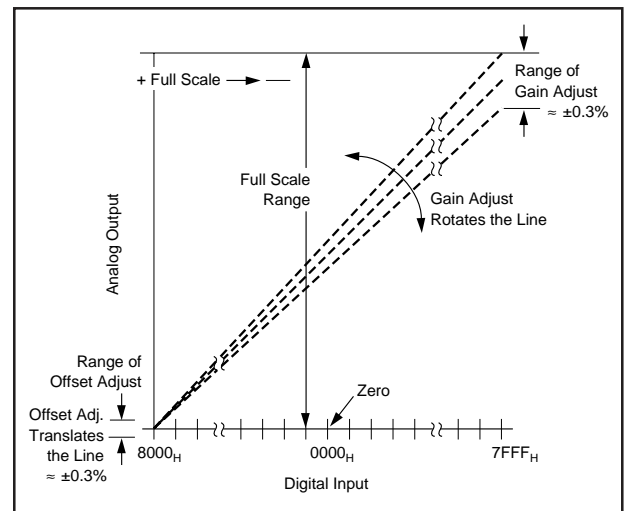

FIGURE 3. Relationship of Offset and Gain Adjustments.

### GAIN AND OFFSET ADJUSTMENTS

Figure 3 illustrates the relationship of offset and gain adjustments for a unipolar connected D/A converter. Offset should be adjusted first to avoid interaction of adjustments. See Table I for calibration values and codes. These adjustments have a minimum range of  $\pm 0.3\%$ .

### Offset Adjustment

Apply the digital input code that produces zero output voltage and adjust the offset potentiometer or the offset adjust D/A converter for 0V.

DAC715 CALIBRATION VALUES 1 LEAST SIGNIFICANT BIT = 152 $\mu$ V		
DIGITAL INPUT CODE BINARY TWO'S COMPLEMENT, BTC	ANALOG OUTPUT (V)	DESCRIPTION
7FFF <sub>H</sub>	9.999847	Full Scale -1LSB
4000 <sub>H</sub>	7.5	3/4 Scale
0001 <sub>H</sub>	5.000152	Half Scale + 1LSB
0000 <sub>H</sub>	5	Half Scale
FFFF <sub>H</sub>	4.999847	Half Scale - 1LSB
C000 <sub>H</sub>	2.5	1/4 Scale
8000 <sub>H</sub>	0	Zero

TABLE I. Digital Input and Analog Output Voltage Calibration Values.

### Gain Adjustment

Apply the digital input that gives the maximum positive voltage output. Adjust the gain potentiometer or the gain adjust D/A converter for this positive full scale voltage.

## INSTALLATION

### GENERAL CONSIDERATIONS

Due to the high-accuracy of the DAC715, system design problems such as grounding and contact resistance become very important. A 16-bit converter with a 10V full-scale range has a 1LSB value of 152 $\mu$ V. With a load current of 5mA, series wiring and connector resistance of only 60m $\Omega$  will cause a voltage drop of 300 $\mu$ V. To understand what this means in terms of a system layout, the resistivity of a typical 1 ounce copper-clad printed circuit board is 1/2 m $\Omega$  per square. For a 5mA load, a 10 milliinch wide printed circuit conductor 60 milliinches long will result in a voltage drop of 150 $\mu$ V.

The analog output of DAC715 has an LSB size of 152 $\mu$ V (-96dB). The noise floor of the D/A must remain below this level in the frequency range of interest. The DAC715's noise spectral density (which includes the noise contributed by the internal reference) is shown in the Typical Performance Curves section.

Wiring to high-resolution D/A converters should be routed to provide optimum isolation from sources of RFI and EMI. The key to elimination of RF radiation or pickup is small loop area. Signal leads and their return conductors should be kept close together such that they present a small capture cross-section for any external field. Wire-wrap construction is not recommended.

### POWER SUPPLY AND REFERENCE CONNECTIONS

Power supply decoupling capacitors should be added as shown in Figure 4. Best performance occurs using a 1 to 10 $\mu$ F tantalum capacitor at  $-V_{CC}$ . Applications with less critical settling time may be able to use 0.01 $\mu$ F at  $-V_{CC}$  as

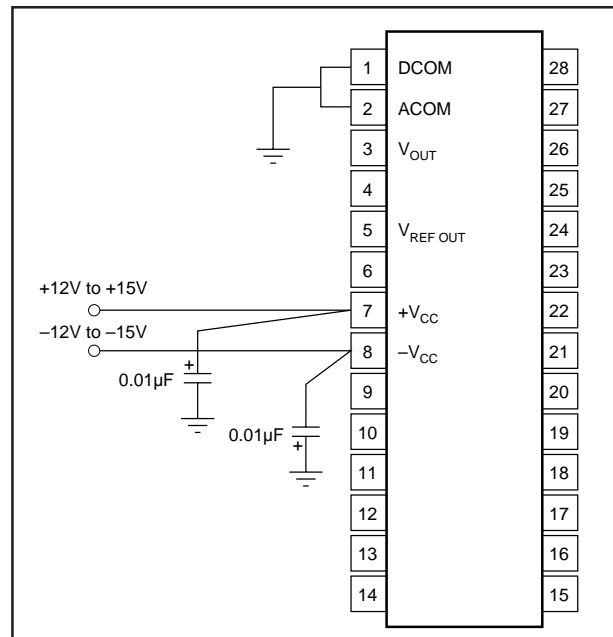

FIGURE 4. Power Supply Connections.

well as at  $+V_{CC}$ . The capacitors should be located close to the package.

The DAC715 has separate ANALOG COMMON and DIGITAL COMMON pins. The current through DCOM is mostly switching transients and are up to 1mA peak in amplitude. The current through ACOM is typically 5 $\mu$ A for all codes.

Use separate analog and digital ground planes with a single interconnection point to minimize ground loops. The analog pins are located adjacent to each other to help isolate analog from digital signals. Analog signals should be routed as far as possible from digital signals and should cross them at right angles. A solid analog ground plane around the D/A package, as well as under it in the vicinity of the analog and power supply pins, will isolate the D/A from switching currents. It is recommended that DCOM and ACOM be connected directly to the ground planes under the package.

If several DAC715s are used or if DAC715 shares supplies with other components, connecting the ACOM and DCOM lines together once at the power supplies rather than at each chip may give better results.

### LOAD CONNECTIONS

Since the reference point for  $V_{OUT}$  and  $V_{REF OUT}$  is the ACOM pin, it is important to connect the D/A converter load directly to the ACOM pin. Refer to Figure 5.

Lead and contact resistances are represented by  $R_1$  through  $R_3$ . As long as the load resistance  $R_L$  is constant,  $R_1$  simply introduces a gain error and can be removed by gain adjustment of the D/A or system-wide gain calibration.  $R_2$  is part of  $R_L$  if the output voltage is sensed at ACOM.

In some applications it is impractical to return the load to the ACOM pin of the D/A converter. Sensing the output voltage at the SYSTEM GROUND point is reasonable, because there is no change in DAC715 ACOM current, provided that



$R_3$  is a low-resistance ground plane or conductor. In this case you may wish to connect DCOM to SYSTEM GROUND as well.

## GAIN AND OFFSET ADJUST

### Connections Using Potentiometers

GAIN and OFFSET adjust pins provide for trim using external potentiometers. 15-turn potentiometers provide sufficient resolution. Range of adjustment of these trims is at least  $\pm 0.3\%$  of Full Scale Range. Refer to Figure 6.

### Using D/A Converters

The GAIN ADJUST and OFFSET ADJUST circuits of the DAC715 have been arranged so that these points may be easily driven by external D/A converters. Refer to Figure 7. 12-bit D/A converters provide an OFFSET adjust resolution and a GAIN adjust resolution of  $30\mu\text{V}$  to  $50\mu\text{V}$  per LSB step.

Nominal values of GAIN and OFFSET occur when the D/A

converters outputs are at approximately half scale,  $0\text{V}$ .

## DIGITAL INTERFACE

### BUS INTERFACE

The DAC715 has a 16-bit double-buffered data interface with control lines for easy connection to a 16-bit bus. The double-buffered feature permits update of several D/As simultaneously.

$A_0$  is the enable control for the DATA INPUT LATCH.  $A_1$  is the enable for the D/A LATCH.  $\overline{WR}$  is used to strobe data into latches enabled by  $A_0$ , and  $\overline{A_1}$ . Refer to the block diagram of Figure 1 and to Timing Diagram on page 3.

CLR sets the INPUT DATA LATCH and D/A LATCH to  $0000_H$  ( $5\text{V}$  at the D/A output).

### SINGLE-BUFFERED OPERATION

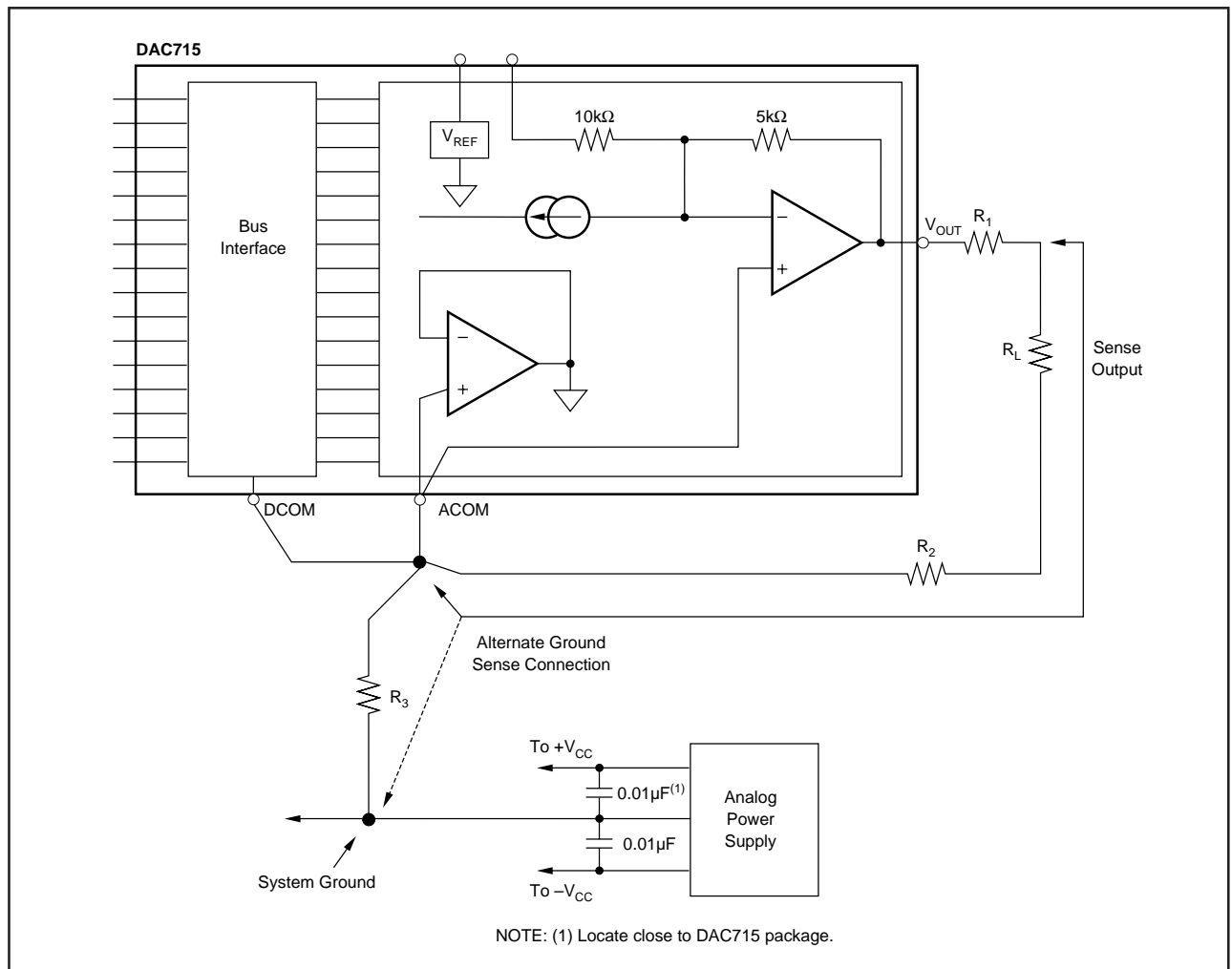

FIGURE 5. System Ground Considerations for High-Resolution D/A Converters.

To operate the DAC715 interface as a single-buffered latch, the DATA INPUT LATCH is permanently enabled by connecting  $A_0$  to DCOM. If  $A_1$  is not used to enable the D/A, it should be connected to DCOM also. For this mode of operation, the width of WR will need to be at least 80ns minimum to pass data through the DATA INPUT LATCH and into the D/A LATCH.

The digital interface of the DAC715 can be made transparent by asserting  $A_0$ ,  $A_1$ , and WR LOW, and asserting CLR HIGH.

### TRANSPARENT INTERFACE

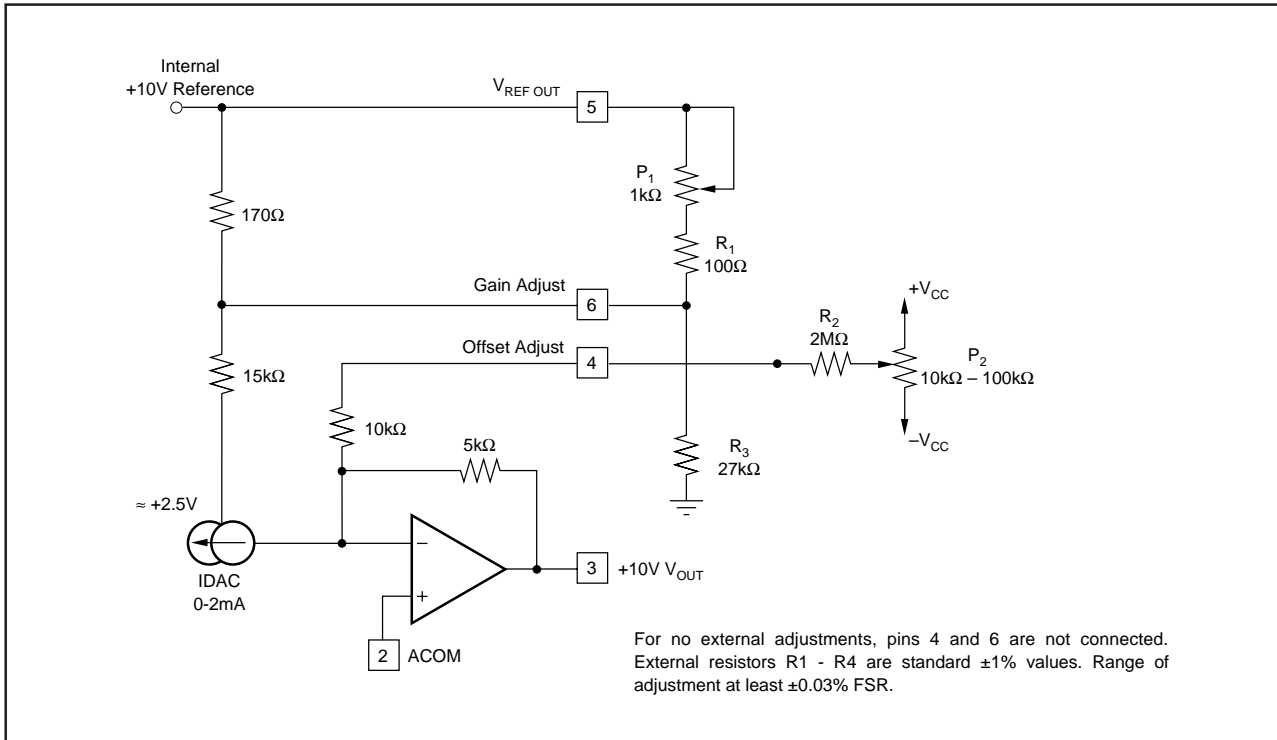

FIGURE 6. Manual Offset and Gain Adjust Circuits.

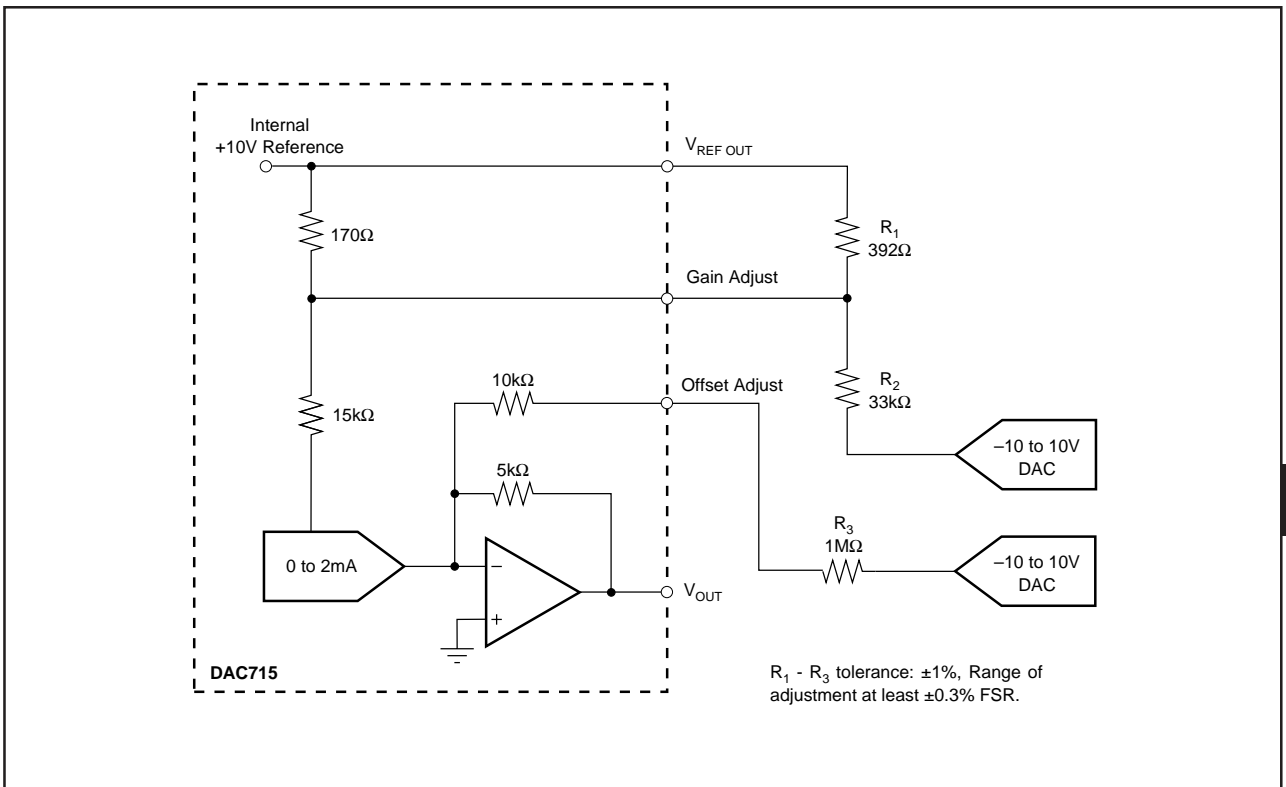

FIGURE 7. Gain and Offset Adjustment Using D/A Converters.

**PACKAGING INFORMATION**

Orderable Device	Status (1)	Package Type	Package Drawing	Pins	Package Qty	Eco Plan (2)	Lead/Ball Finish (6)	MSL Peak Temp (3)	Op Temp (°C)	Device Marking (4/5)	Samples
DAC715P	LIFEBUY	PDIP	NT	28	13	Green (RoHS & no Sb/Br)	CU NIPDAU	N / A for Pkg Type	-40 to 85	DAC715P L	
DAC715PB	LIFEBUY	PDIP	NT	28	13	Green (RoHS & no Sb/Br)	CU NIPDAU	N / A for Pkg Type	-40 to 85	DAC715P B	
DAC715PBG4	LIFEBUY	PDIP	NT	28	13	Green (RoHS & no Sb/Br)	CU NIPDAU	N / A for Pkg Type	-40 to 85	DAC715P B	
DAC715PG4	LIFEBUY	PDIP	NT	28	13	Green (RoHS & no Sb/Br)	CU NIPDAU	N / A for Pkg Type	-40 to 85	DAC715P L	
DAC715PK	LIFEBUY	PDIP	NT	28	13	Green (RoHS & no Sb/Br)	CU NIPDAU	N / A for Pkg Type	0 to 70	DAC715P K	
DAC715PKG4	LIFEBUY	PDIP	NT	28	13	Green (RoHS & no Sb/Br)	CU NIPDAU	N / A for Pkg Type	0 to 70	DAC715P K	
DAC715PL	LIFEBUY	PDIP	NT	28	13	Green (RoHS & no Sb/Br)	CU NIPDAU	N / A for Pkg Type	0 to 70	DAC715P L	
DAC715PLG4	LIFEBUY	PDIP	NT	28	13	Green (RoHS & no Sb/Br)	CU NIPDAU	N / A for Pkg Type	0 to 70	DAC715P L	
DAC715U	ACTIVE	SOIC	DW	28	20	Green (RoHS & no Sb/Br)	CU NIPDAU	Level-3-260C-168 HR	-40 to 85	DAC715U	<a href="#">Samples</a>
DAC715UB	ACTIVE	SOIC	DW	28	20	Green (RoHS & no Sb/Br)	CU NIPDAU	Level-3-260C-168 HR	-40 to 85	DAC715U B	<a href="#">Samples</a>
DAC715UK	ACTIVE	SOIC	DW	28	20	Green (RoHS & no Sb/Br)	CU NIPDAU	Level-3-260C-168 HR	0 to 70	DAC715U K	<a href="#">Samples</a>
DAC715UKG4	ACTIVE	SOIC	DW	28	20	Green (RoHS & no Sb/Br)	CU NIPDAU	Level-3-260C-168 HR	0 to 70	DAC715U K	<a href="#">Samples</a>
DAC715UL	ACTIVE	SOIC	DW	28	20	Green (RoHS & no Sb/Br)	CU NIPDAU	Level-3-260C-168 HR	0 to 70	DAC715U L	<a href="#">Samples</a>

(1) The marketing status values are defined as follows:

**ACTIVE:** Product device recommended for new designs.

**LIFEBUY:** TI has announced that the device will be discontinued, and a lifetime-buy period is in effect.

**NRND:** Not recommended for new designs. Device is in production to support existing customers, but TI does not recommend using this part in a new design.

**PREVIEW:** Device has been announced but is not in production. Samples may or may not be available.

**OBSOLETE:** TI has discontinued the production of the device.

<sup>(2)</sup> Eco Plan - The planned eco-friendly classification: Pb-Free (RoHS), Pb-Free (RoHS Exempt), or Green (RoHS & no Sb/Br) - please check <http://www.ti.com/productcontent> for the latest availability information and additional product content details.

**TBD:** The Pb-Free/Green conversion plan has not been defined.

**Pb-Free (RoHS):** TI's terms "Lead-Free" or "Pb-Free" mean semiconductor products that are compatible with the current RoHS requirements for all 6 substances, including the requirement that lead not exceed 0.1% by weight in homogeneous materials. Where designed to be soldered at high temperatures, TI Pb-Free products are suitable for use in specified lead-free processes.

**Pb-Free (RoHS Exempt):** This component has a RoHS exemption for either 1) lead-based flip-chip solder bumps used between the die and package, or 2) lead-based die adhesive used between the die and leadframe. The component is otherwise considered Pb-Free (RoHS compatible) as defined above.

**Green (RoHS & no Sb/Br):** TI defines "Green" to mean Pb-Free (RoHS compatible), and free of Bromine (Br) and Antimony (Sb) based flame retardants (Br or Sb do not exceed 0.1% by weight in homogeneous material)

<sup>(3)</sup> MSL, Peak Temp. - The Moisture Sensitivity Level rating according to the JEDEC industry standard classifications, and peak solder temperature.

<sup>(4)</sup> There may be additional marking, which relates to the logo, the lot trace code information, or the environmental category on the device.

<sup>(5)</sup> Multiple Device Markings will be inside parentheses. Only one Device Marking contained in parentheses and separated by a "~" will appear on a device. If a line is indented then it is a continuation of the previous line and the two combined represent the entire Device Marking for that device.

<sup>(6)</sup> Lead/Ball Finish - Orderable Devices may have multiple material finish options. Finish options are separated by a vertical ruled line. Lead/Ball Finish values may wrap to two lines if the finish value exceeds the maximum column width.

**Important Information and Disclaimer:** The information provided on this page represents TI's knowledge and belief as of the date that it is provided. TI bases its knowledge and belief on information provided by third parties, and makes no representation or warranty as to the accuracy of such information. Efforts are underway to better integrate information from third parties. TI has taken and continues to take reasonable steps to provide representative and accurate information but may not have conducted destructive testing or chemical analysis on incoming materials and chemicals. TI and TI suppliers consider certain information to be proprietary, and thus CAS numbers and other limited information may not be available for release.

In no event shall TI's liability arising out of such information exceed the total purchase price of the TI part(s) at issue in this document sold by TI to Customer on an annual basis.

## IMPORTANT NOTICE

Texas Instruments Incorporated and its subsidiaries (TI) reserve the right to make corrections, enhancements, improvements and other changes to its semiconductor products and services per JESD46, latest issue, and to discontinue any product or service per JESD48, latest issue. Buyers should obtain the latest relevant information before placing orders and should verify that such information is current and complete. All semiconductor products (also referred to herein as "components") are sold subject to TI's terms and conditions of sale supplied at the time of order acknowledgment.

TI warrants performance of its components to the specifications applicable at the time of sale, in accordance with the warranty in TI's terms and conditions of sale of semiconductor products. Testing and other quality control techniques are used to the extent TI deems necessary to support this warranty. Except where mandated by applicable law, testing of all parameters of each component is not necessarily performed.

TI assumes no liability for applications assistance or the design of Buyers' products. Buyers are responsible for their products and applications using TI components. To minimize the risks associated with Buyers' products and applications, Buyers should provide adequate design and operating safeguards.

TI does not warrant or represent that any license, either express or implied, is granted under any patent right, copyright, mask work right, or other intellectual property right relating to any combination, machine, or process in which TI components or services are used. Information published by TI regarding third-party products or services does not constitute a license to use such products or services or a warranty or endorsement thereof. Use of such information may require a license from a third party under the patents or other intellectual property of the third party, or a license from TI under the patents or other intellectual property of TI.

Reproduction of significant portions of TI information in TI data books or data sheets is permissible only if reproduction is without alteration and is accompanied by all associated warranties, conditions, limitations, and notices. TI is not responsible or liable for such altered documentation. Information of third parties may be subject to additional restrictions.

Resale of TI components or services with statements different from or beyond the parameters stated by TI for that component or service voids all express and any implied warranties for the associated TI component or service and is an unfair and deceptive business practice. TI is not responsible or liable for any such statements.

Buyer acknowledges and agrees that it is solely responsible for compliance with all legal, regulatory and safety-related requirements concerning its products, and any use of TI components in its applications, notwithstanding any applications-related information or support that may be provided by TI. Buyer represents and agrees that it has all the necessary expertise to create and implement safeguards which anticipate dangerous consequences of failures, monitor failures and their consequences, lessen the likelihood of failures that might cause harm and take appropriate remedial actions. Buyer will fully indemnify TI and its representatives against any damages arising out of the use of any TI components in safety-critical applications.

In some cases, TI components may be promoted specifically to facilitate safety-related applications. With such components, TI's goal is to help enable customers to design and create their own end-product solutions that meet applicable functional safety standards and requirements. Nonetheless, such components are subject to these terms.

No TI components are authorized for use in FDA Class III (or similar life-critical medical equipment) unless authorized officers of the parties have executed a special agreement specifically governing such use.

Only those TI components which TI has specifically designated as military grade or "enhanced plastic" are designed and intended for use in military/aerospace applications or environments. Buyer acknowledges and agrees that any military or aerospace use of TI components which have **not** been so designated is solely at the Buyer's risk, and that Buyer is solely responsible for compliance with all legal and regulatory requirements in connection with such use.

TI has specifically designated certain components as meeting ISO/TS16949 requirements, mainly for automotive use. In any case of use of non-designated products, TI will not be responsible for any failure to meet ISO/TS16949.

### Products

Audio	<a href="http://www.ti.com/audio">www.ti.com/audio</a>
Amplifiers	<a href="http://amplifier.ti.com">amplifier.ti.com</a>
Data Converters	<a href="http://dataconverter.ti.com">dataconverter.ti.com</a>
DLP® Products	<a href="http://www.dlp.com">www.dlp.com</a>
DSP	<a href="http://dsp.ti.com">dsp.ti.com</a>
Clocks and Timers	<a href="http://www.ti.com/clocks">www.ti.com/clocks</a>
Interface	<a href="http://interface.ti.com">interface.ti.com</a>
Logic	<a href="http://logic.ti.com">logic.ti.com</a>
Power Mgmt	<a href="http://power.ti.com">power.ti.com</a>
Microcontrollers	<a href="http://microcontroller.ti.com">microcontroller.ti.com</a>
RFID	<a href="http://www.ti-rfid.com">www.ti-rfid.com</a>
OMAP Applications Processors	<a href="http://www.ti.com/omap">www.ti.com/omap</a>
Wireless Connectivity	<a href="http://www.ti.com/wirelessconnectivity">www.ti.com/wirelessconnectivity</a>

### Applications

Automotive and Transportation	<a href="http://www.ti.com/automotive">www.ti.com/automotive</a>
Communications and Telecom	<a href="http://www.ti.com/communications">www.ti.com/communications</a>
Computers and Peripherals	<a href="http://www.ti.com/computers">www.ti.com/computers</a>
Consumer Electronics	<a href="http://www.ti.com/consumer-apps">www.ti.com/consumer-apps</a>
Energy and Lighting	<a href="http://www.ti.com/energy">www.ti.com/energy</a>
Industrial	<a href="http://www.ti.com/industrial">www.ti.com/industrial</a>
Medical	<a href="http://www.ti.com/medical">www.ti.com/medical</a>
Security	<a href="http://www.ti.com/security">www.ti.com/security</a>
Space, Avionics and Defense	<a href="http://www.ti.com/space-avionics-defense">www.ti.com/space-avionics-defense</a>
Video and Imaging	<a href="http://www.ti.com/video">www.ti.com/video</a>

### TI E2E Community

[e2e.ti.com](http://e2e.ti.com)