

RF CHARACTERISTICS

Frequency range : **0 - 26.5 GHz**
Impedance : **50 Ohms**

Frequency (GHz)	DC - 3	3 - 8	8 - 12.4	12.4 - 18	18 - 26.5
VSWR max	1.20	1.30	1.40	1.50	1.70
Insertion loss max	0.20 dB	0.30 dB	0.40 dB	0.50 dB	0.70 dB
Isolation min	80 dB	70 dB	60 dB	60 dB	55 dB
Average power (*)	240 W	150 W	120 W	100 W	40 W

ELECTRICAL CHARACTERISTICS

Actuator : **NORMALLY OPEN**
Nominal current ** : **102 mA**
Actuator voltage (Vcc) : **28V (24 to 30V)**
Terminals : **solder pins (250°C max. / 30 sec.)**
TTL inputs (E) - High level : **2.2 to 5.5 V / 800µA at 5.5 V**
- Low level : **0 to 0.8 V / 20µA at 0.8 V**

MECHANICAL CHARACTERISTICS

Connectors : **SMA female per MIL-C 39012**
Life : **2 million cycles**
Switching Time*** : **< 10 ms**
Construction : **Splashproof**
Weight : **< 100 g**

ENVIRONMENTAL CHARACTERISTICS

Operating temperature range : **-40°C to +85°C**
Storage temperature range : **-55°C to +85°C**

(* Average power at 25°C per RF Path)

(** At 25° C ±10%)

(*** Nominal voltage ; 25° C)



PAGE 2/2

ISSUE 09-03-21

SERIE : SPDT ZC

PART NUMBER : R585F73300

DRAWING

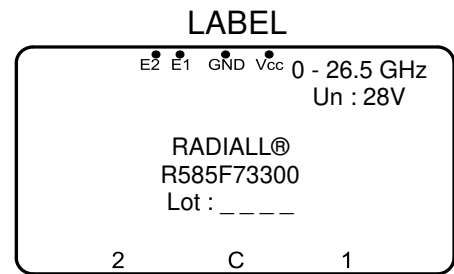
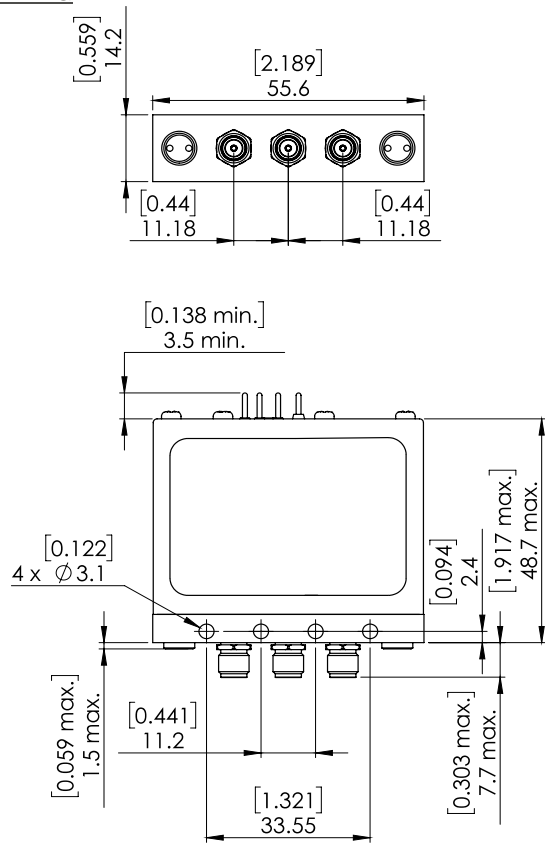

General tolerances : ±0,5 mm [0,02 in]

SCHEMATIC DIAGRAM

RF input

50Ω Termination

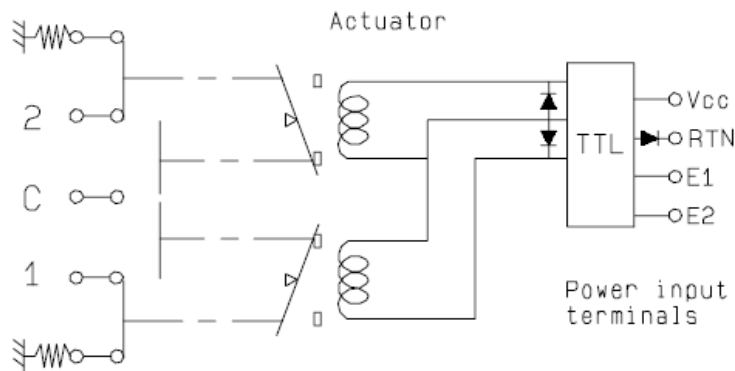

50Ω Termination

TTL input	RF Continuity
E1=1 / E2=0	C↔1 / 2↔50Ω
E1=0 / E2=1	C↔2 / 1↔50Ω
E1=0 / E2=0	1↔50Ω / 2↔50Ω
E1=1 / E2=1	Forbidden