

- 1 MATERIAL:  
HOUSING, BRACKET, ADAPTER COMB & PLATE - THERMOPLASTIC, BLACK, 94V-0 RATED  
TERMINALS - HIGH STRENGTH COPPER ALLOY PLATED WITH EITHER .000030 MIN GOLD PLATE OR GOLD FLASH OVER PALLADIUM NICKEL PLATE .000030 MIN TOTAL ON MATING SURFACE. .000120 MIN TIN-LEAD PLATE ON TAILS. ALL OVER .000050 MIN NICKEL UNDERPLATE OVER ENTIRE TERMINAL.
- 2 TERMINAL 1 IS LOCATED IN THIS ROW FOR 552741-1.
- 3 TERMINAL SUPPORT PLATE CLEARANCE FOR TERMINAL STRAIN RELIEF AND FLUX REMOVAL.
- 4 PANEL THICKNESS RANGE: .062 MAX.
- 5 DETAIL A IS VIEWED FROM MATING SIDE OF PLUG ASSEMBLY.
- 6 FOR USE WITH A NO. 4 BT TYPE SELF TAPPING SCREW.

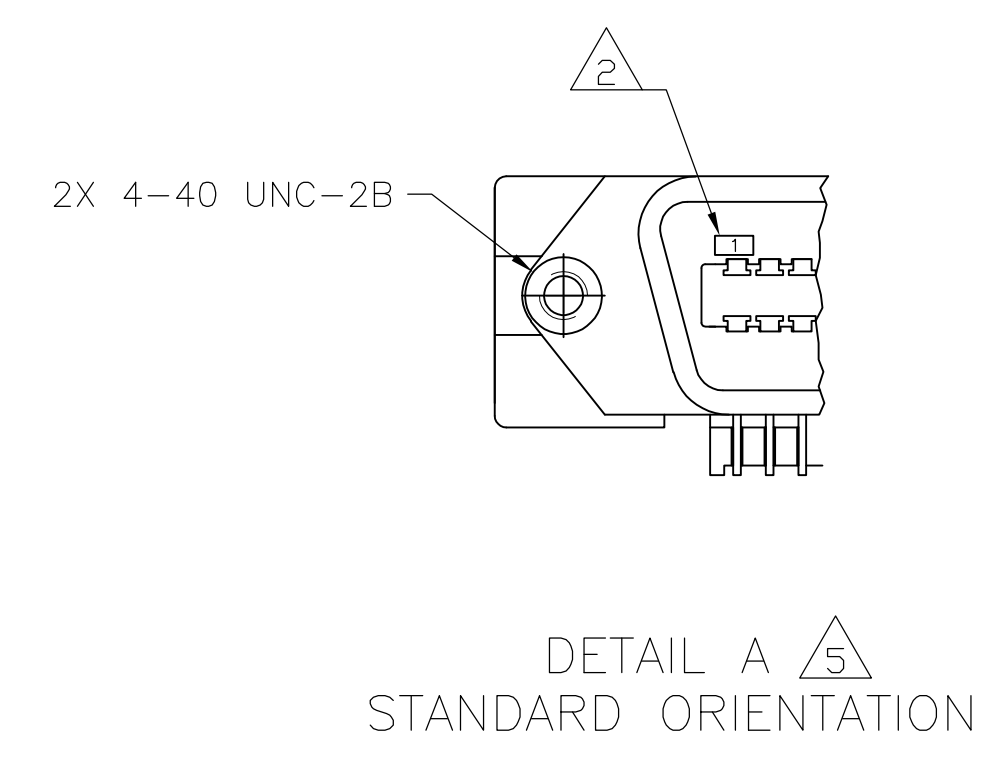
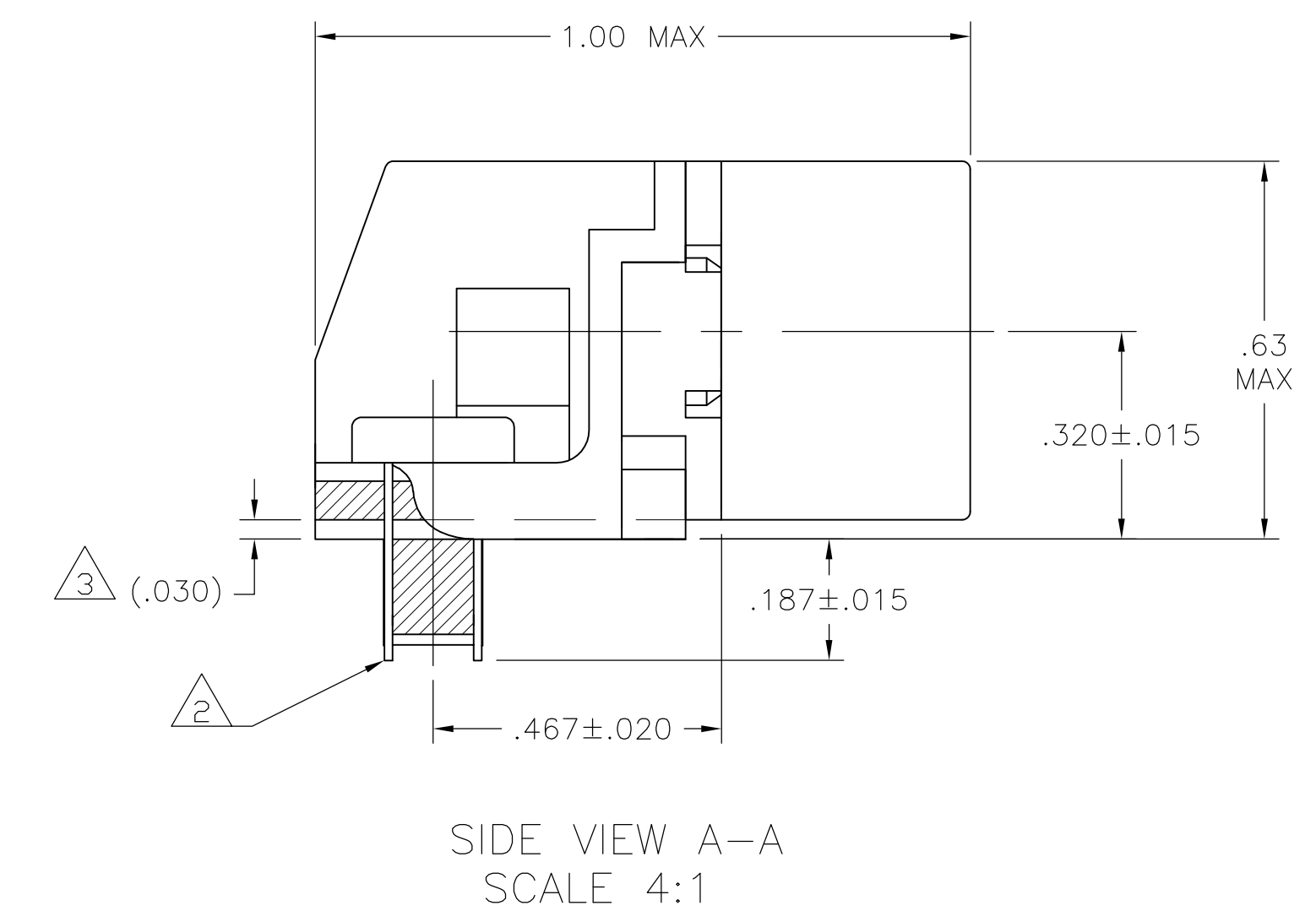
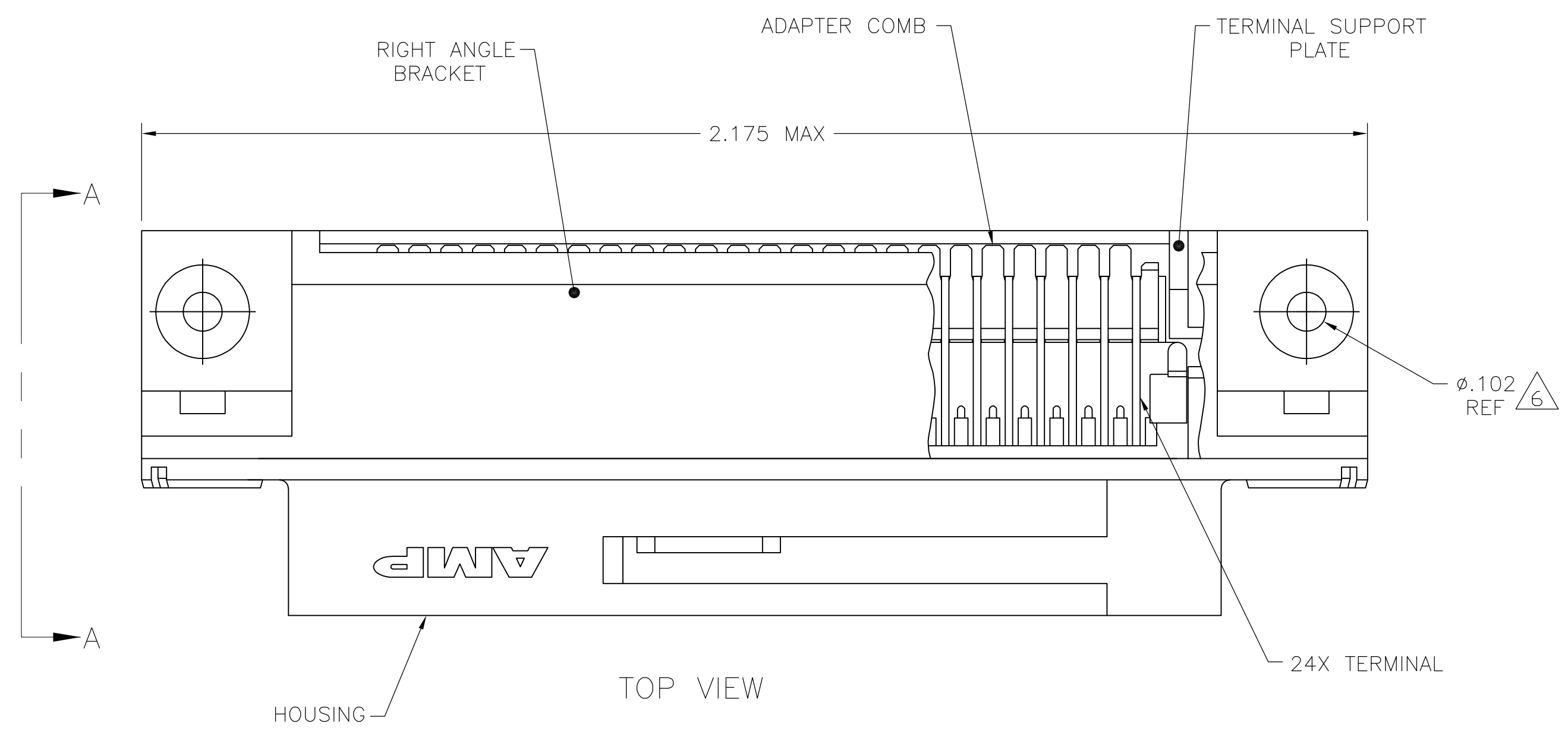

OBsolete	552741-2
SELF-TAPPING 6	SEE DETAIL A 2
TYPE OF MOUNTING	DESCRIPTION
	PART NUMBER

THIS DRAWING IS A CONTROLLED DOCUMENT.		DIN Z REAM 2/APR/07		Tyco Electronics Tyco Electronics Corporation Harrisburg, PA 17105-3608	
DIMENSIONS: INCHES		TOLERANCES UNLESS OTHERWISE SPECIFIED:		NAME	
0 PLC ± -		1 PLC ± -		PLUG ASSEMBLY, 24 POSN, RIGHT ANGLE, PRINTED CIRCUIT BOARD (CHAMP-LOK, THRU-BOLT & SELF-TAPPING)	
1 PLC ± -		2 PLC ± -		SIZE	
2 PLC ± -		3 PLC ± .005		A1	
3 PLC ± -		4 PLC ± -		CAGE CODE	
4 PLC ± -		ANGLES ± -		00779	
MATERIAL 1		FINISH 1		DRAWING NO	
				552741	
				RESTRICTED TO	
				CUSTOMER DRAWING	
				SCALE 2:1 SHEET 1 OF 1 REV U	