

THIS DRAWING IS UNPUBLISHED. RELEASED FOR PUBLICATION
 © COPYRIGHT - By - ALL RIGHTS RESERVED.

REVISIONS				
P	LTR	DESCRIPTION	DATE	APVD
F2		DRAWING ERROR RECTIFICATION	02AUG2017	SV

- 1 CONTINUOUS STRIP ON REELS WITH TERMINALS LOCATED ON 6.86 ± 0.08 [$.270 \pm .003$] CENTERS
- 2 SLOT ACCEPTS 0.25-0.32mm [#30-#28] AWG COPPER MAGNET WIRE. TWO WIRES OF THE SAME SIZE MAX PER SLOT
- 3 IDENTIFICATION NUMBER 6 FOR THE MAGNET WIRE SLOT SIZE
- 4 0.25[.010] MAX CARRIER CUT-OFF TABS

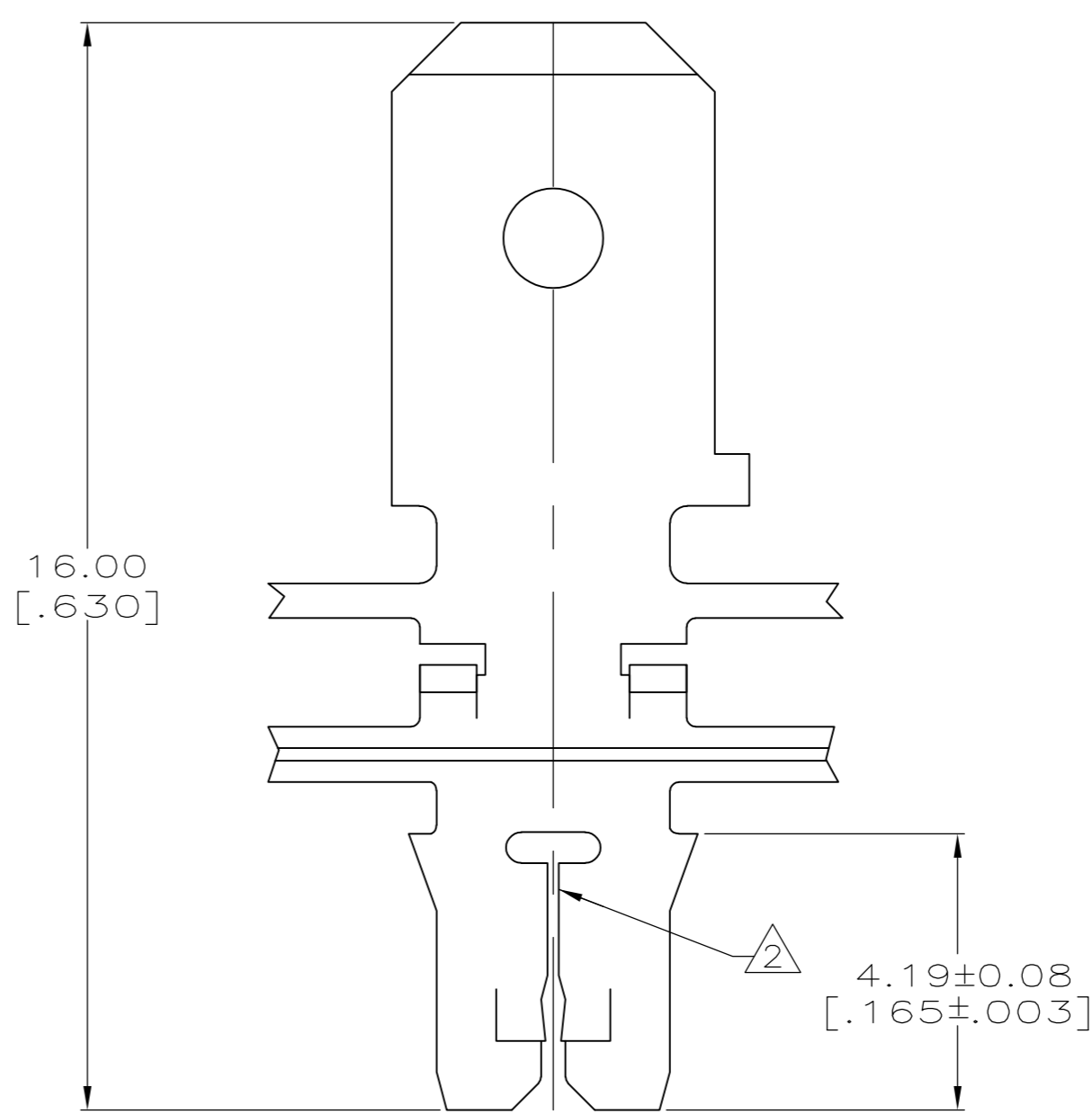
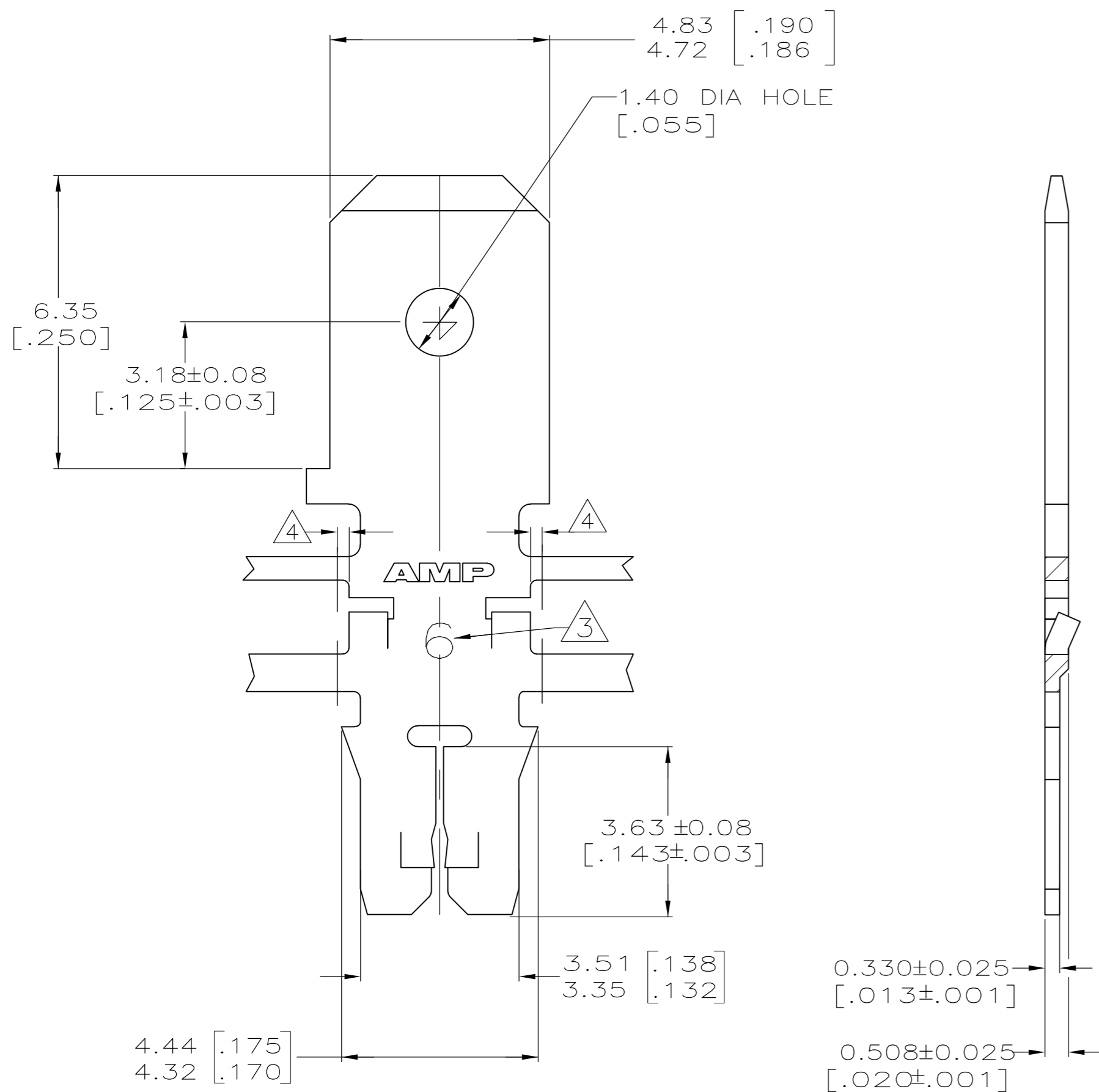

OBSOLETE	082 BRASS	63711-2
	4M BRASS	63711-1
	MATERIAL	PART NO.

THIS DRAWING IS A CONTROLLED DOCUMENT.		DWN L.A.MAYER 9-27-93	TE TE Connectivity	
DIMENSIONS: INCHES		CHK M.S. FEHER 9-27-93		
TOLERANCES UNLESS OTHERWISE SPECIFIED:		APVD A. HUNT III 9-27-93	NAME	
0 PLC ± -		PRODUCT SPEC	TAB, 4.75 [.187] FASTON™	
1 PLC ± -		APPLICATION SPEC	MAG-MATE™ Slim Line	
2 PLC ± 0.13 [.005]		114-2140	SIZE	CAGE CODE
3 PLC ± -		WEIGHT 0.000000	A2	00779
4 PLC ± -		CUSTOMER DRAWING	DRAWING NO	RESTRICTED TO
ANGLES ± -		SCALE 10:1	SHEET 1 of 1	REV F2
FINISH TIN PLATED				