

FEMALE PLUG M12 STRAIGHT

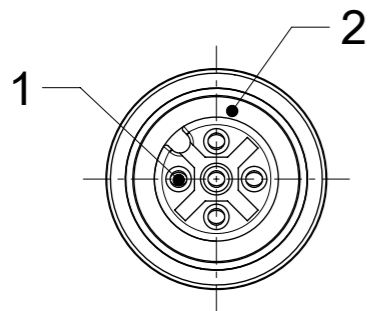

NOTES:

RATED VOLTAGE: 3, 4 contacts 250V

5 contacts 60V

8 contacts 30V

RATED CURRENT: 3, 4, 5 contacts 4A

8 contacts 2A

PROTECTION CLASS: IP 67

TEMPERATURE: -25°C / +85°C

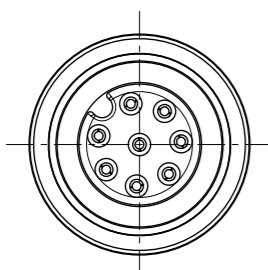

Thicker Overmold for Cables with bigger Outer Diameter

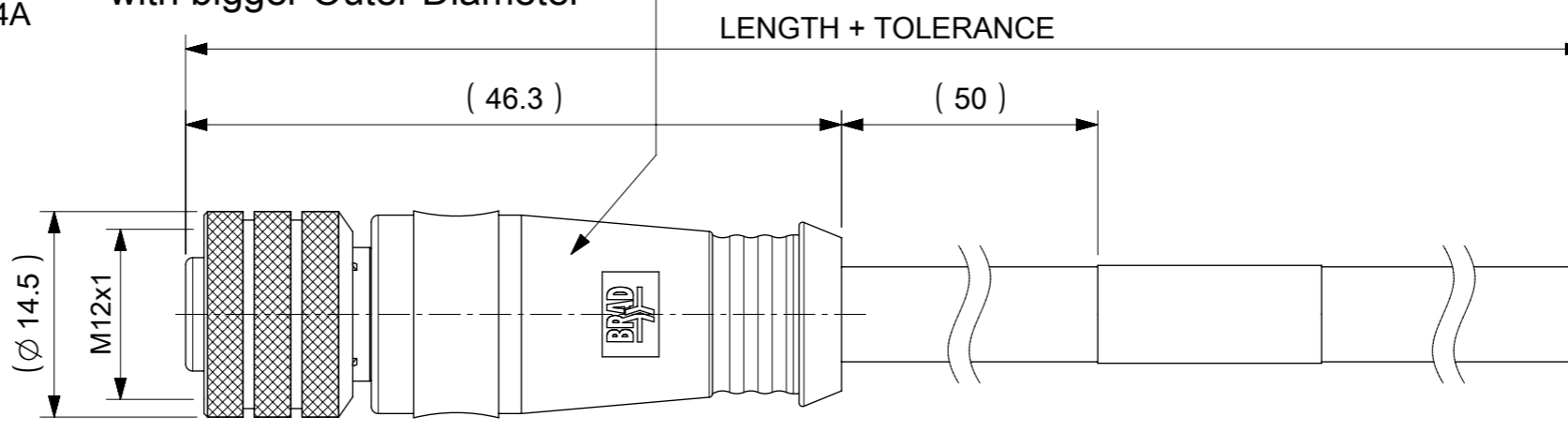

For Shielded Cables testing ends are cut off after test

CONTACTS POSITION FRONT VIEW:

3 CONTACTS		4 CONTACTS		5 CONTACTS		8 CONTACTS	
PIN	WIRE	PIN	WIRE	PIN	WIRE	PIN	WIRE
1	BROWN	1	BROWN	1	BROWN	1	WHITE
2	---	2	WHITE	2	WHITE	2	BROWN
3	BLUE	3	BLUE	3	BLUE	3	GREEN
4	BLACK OR YELLOW/GREEN	4	BLACK	4	BLACK	4	YELLOW
5	---	5	---	5	GREY OR YELLOW/GREEN	5	GREY
						6	PINK
						7	BLUE
						8	RED

FOR OPTIONS SEE - NUMERICAL CODE - ON SHEET 2

ITEM	QTY.	DESCRIPTION	MATERIAL	FINISH
7	1	LABEL YELLOW	VINYL	---
	-	PRINTING FOR CABLES lxx	---	---
6	-	CABLE	SEE SHEET 2	---
5	-	OVERMOLDING BLACK	TPU	---
4	1	COUPLING NUT FEMALE	BRASS	NICKEL
3	1	INSERT FEMALE BLACK	PUR	---
2	1	ORING RED	FPM	---
1	3 / 4 / 5 / 8	CONTACT M12 FEMALE	BRASS	SELECTIVE Au OVER Ni

THIS DRAWING CONTAINS INFORMATION THAT IS PROPRIETARY TO MOLEX ELECTRONIC TECHNOLOGIES, LLC AND SHOULD NOT BE USED WITHOUT WRITTEN PERMISSION

DIMENSION UNITS: mm SCALE: 2:1

GENERAL TOLERANCES (UNLESS SPECIFIED): ANGULAR TOL ± 1.0°

4 PLACES ± 0.15
3 PLACES ± 0.10
2 PLACES ± 0.05
1 PLACE ± 0.3
0 PLACES ± 0.5

EC NO: 726454
DRWN: LIKITV 2022/09/28
CHK'D: GGA 2022/11/30
APPR: GGA 2022/11/30

INITIAL REVISION:
DRWN: JMARSZALEK 2016/01/12
APPR: RSILLER 2016/04/08

DOCUMENT NUMBER: 1200658605
DOC TYPE: PSD
DOC PART: 000
REVISION: A6

THIRD ANGLE PROJECTION

DRAWING: A3-SIZE
SERIES: 120065
MATERIAL NUMBER: SEE PART LIST
CUSTOMER: GENERAL MARKET
SHEET NUMBER: 1 OF 4

DOCUMENT STATUS: P1 RELEASE DATE: 2022/11/30 11:33:45

ENGINEERING NO. - NUMERICAL CODE (Available parts see PART LIST table. Others on request).

8 0 X 0 0 0 X X X X X X X X

80=M12x1
Single ended

Contacts:
3=3 Contacts
4=4 Contacts
5=5 Contacts
8=8 Contacts

Heads style:
000=Plug Female Straight

Cable type: See Table

Units:
M=Meter
C=Centimeter

Length
Examples:
005=0.5 unit
010=1 unit
100=10 units

Options

Overmold color:
Blank (Standard)=Black TPU
Blank=Yellow TPU for cables A09,S19,S20,S26
Blank=Yellow TPE-E for cables K03,K05
A=Grey / G=Black / Y=Yellow

Coupling Nut:
Blank (Standard) & 3=Knurled Brass Ni Plated
1=Hexagonal Stainless steel
5=Knurled Derlin
7=Knurled Brass Ni Plated, Teflon Coated
Blank=7 for cables I20, I26, K03, K05, P82, S26
9=Knurled / Hexagonal Brass Ni Plated SW13



COUPLING NUTS

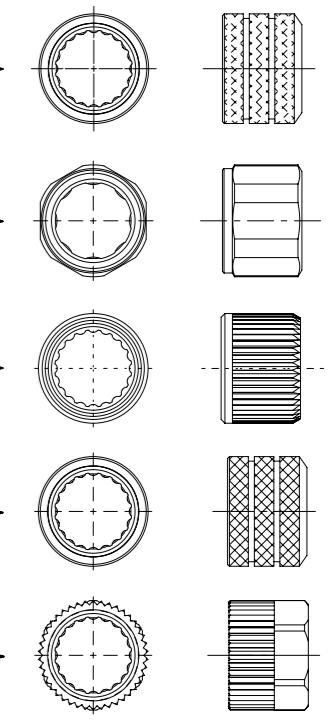

CABLE INFORMATION (for more information see Cable Data Sheet).

CABLE TYPE	NO. OF WIRES	CROSS SECTION	CABLE JACKET	UL	CSA	STATIC: TEMP. / BENDING RADIUS	DYNAMIC: TEMP. / BENDING RADIUS	DRAG CHAIN	SHIELD
E13	3	18AWG	PVC YELLOW	UL 2661/1731	I/II A/B 80°C/300V	-	-	-	-
E52	3 / 4 / 8	0.34mm ²	PVC GREY	-	-	-30°C to +70°C	-5°C to +70°C	-	-
E63	5	0.34mm ²	PVC GREY	-	-	-30°C to +70°C	-5°C to +70°C	-	YES
H12	4	0.50mm ²	PUR BLACK LS0H	UL 21198/10493	C22.2 I/II A/B 80°C/300V	-50°C to +80°C, 5xO.D.	-25°C to +80°C, 10xO.D.	2 000 000, Temp max 60°C	-
H69	4	0.20mm ²	PUR GREY LS0H	-	-	-	-	-	-
I02	3 / 4 / 8	0.25mm ²	PVC CEI GREY	-	-	-30°C to +70°C	-5°C to +70°C	-	-
I03	3 / 4 / 5	0.34mm ²	PVC CEI GREY	-	-	-30°C to +70°C	-5°C to +70°C	-	-
I04	4	0.50mm ²	PVC CEI GREY	-	-	-25°C to +70°C	-5°C to +70°C	-	-
I20	3 / 4	0.34mm ²	PVC CEI GREY	-	-	-30°C to +70°C	-5°C to +70°C	-	YES
I26	5	0.34mm ²	PVC CEI GREY	-	-	-30°C to +70°C	-5°C to +70°C	-	-
K03	4 / 5	0.34mm ²	TPE YELLOW	UL JEC 60332-1 or PLCT	I/II 90°C/300V	-	-	-	-
K05	3 / 4 / 5	0.34mm ²	TPE YELLOW	UL ITC E195601 or PLC	I/II A/B 90°C/300V	-	-	-	-
P04	4	0.50mm ²	PUR BLACK	-	-	-40°C to +90°C, 7.5xO.D.	-15°C to +90°C, 12.5xO.D.	-	-
P12	3 / 5	0.50mm ²	PUR BLACK	-	-	-30°C to +90°C	-5°C to +90°C	-	-
P19	8	0.25mm ²	PUR BLACK	-	-	-40°C to +90°C, 7.5xO.D.	-15°C to +90°C, 12.5xO.D.	2 000 000 cycles, 15xO.D.	YES
P20	3 / 4 / 5	0.34mm ²	PUR BLACK LS0H	-	-	-30°C to +80°C	-	-	YES
P82	3 / 4 / 5	0.34mm ²	PUR IRR ORANGE	-	-	-50°C to +105°C, 5xO.D.	-40°C to +105°C, 7.5xO.D.	-	-
S19	8	0.25mm ²	PVC YELLOW	UL 2661/1569	C22.2 II A 105°C/300V	-30°C to +105°C, 10xO.D.	-15°C to +105°C, 15xO.D.	-	YES
S20	3 / 4 / 5	0.34mm ²	PVC YELLOW	UL 2661/1731	C22.2 II A 105°C/300V	-30°C to +105°C	-	-	YES
S26	5	0.34mm ²	PVC YELLOW	UL 2661/1731	C22.2 II A 105°C/300V	-30°C to +105°C	-	-	YES

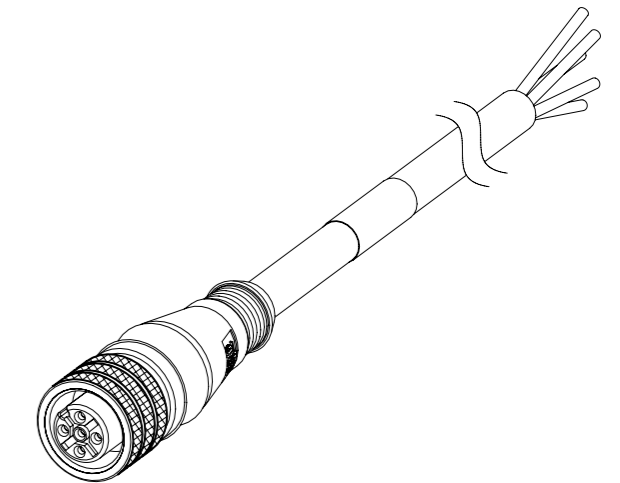

SCALE 1:1

CABLE LENGTH TOLERANCES

OVER	UP TO AND INCLUDING	TOLERANCES
0	305mm	+19mm
305mm	915mm	+45mm
915mm	1830mm	+56mm
1830mm	3660mm	+89mm
3660mm	7320mm	+165mm
7320mm	14640mm	+317mm
14640mm	30500mm	+610mm
30500mm	>	+2% of finished length

THIS DRAWING CONTAINS INFORMATION THAT IS PROPRIETARY TO MOLEX ELECTRONIC TECHNOLOGIES, LLC AND SHOULD NOT BE USED WITHOUT WRITTEN PERMISSION

DIMENSION UNITS mm	SCALE 1:1	CURRENT REV DESC: REMOVED OBSOLETE PART NUMBER AS PER PCN#510807.	molex		
GENERAL TOLERANCES (UNLESS SPECIFIED)					
ANGULAR TOL ± 1.0°	4 PLACES ±	EC NO: 726454	PRODUCT CUSTOMER DRAWING		
3 PLACES ±	CHK'D: GGA	2022/09/28	DOCUMENT NUMBER		
2 PLACES ± 0.05	APPR: GGA	2022/11/30	1200658605		
1 PLACE ± 0.3	INITIAL REVISION:	2016/01/12	DOC TYPE	DOC PART	REVISION
0 PLACES ± 0.5	DRWN: JMARSZALEK	2016/04/08	PSD	000	A6
DRAFT WHERE APPLICABLE MUST REMAIN WITHIN DIMENSIONS	THIRD ANGLE PROJECTION	DRAWING	SERIES	MATERIAL NUMBER	CUSTOMER
		A3-SIZE	120065	SEE PART LIST	GENERAL MARKET
					SHEET NUMBER
					2 OF 4

PART LIST

No.	Part No.	Engineering No.	Cable Length	No.	Part No.	Engineering No.	Cable Length	No.	Part No.	Engineering No.	Cable Length	No.	Part No.	Engineering No.	Cable Length
1	1200060017	804000I03M050	5m	36	1200062037	804000S20M050H	5m	71	1200064073	803000P82M0107	1m	106	1200658256	808000S19M006	0.6m
2	1200060030	803000I03M050	5m	37	1200062040	804000S20M030H	3m	72	1200064161	804000I20M100	10m	107	1200658282	804000P20M250	25m
3	1200060033	804000I03M100	10m	38	1200062049	808000E52M050	5m	73	1200064164	804000I20M020	2m	108	1200658283	805000I03M020	2m
4	1200060145	803000I03M020	2m	39	1200062094	803000H69M050	5m	74	1200064230	804000I03M080	8m	109	1200658293	803000E52M3001A	30m
5	1200060148	803000I03M100	10m	40	1200062268	804000S20M020H	2m	75	1200064254	804000E52M010A	1m	110	1200658299	805000P82M100	10m
6	1200060166	803000S20M010	1m	41	1200062363	804000S20M100H	10m	76	1200064256	803000P82M0207	2m	111	1200658474	805000S20M020	2m
7	1200060167	803000S20M020	2m	42	1200062364	804000P04M020G	2m	77	1200064445	805000P12M023	2.3m	112	1200658524	803000E13M030	3m
8	1200060168	803000S20M030	3m	43	1200062454	803000P82M0067	0.6m	78	1200064490	804000P20M020	2m	113	1200658543	804000I20M150	15m
9	1200060170	803000S20M050	5m	44	1200062496	804000S20M010H	1m	79	1200065005	805000P82M0207	2m	114	1200658593	803000I03M040	4m
10	1200060171	803000S20M100	10m	45	1200062604	804000P20M100	10m	80	1200651108	803000K05M020	2m	115	1200658599	804000I03M010	1m
11	1200060173	803000S20M150	15m	46	1200062656	804000P20M030	3m	81	1200651110	803000K05M050	5m	116	1200658600	804000I03M040	4m
12	1200060436	804000E52M200A	20m	47	1200062657	804000P20M050	5m	82	1200651121	804000K05M020	2m	117	1200658605	805000I03M010	1m
13	1200060452	804000I03M020	2m	48	1200062675	808000P19M030	3m	83	1200651124	804000K05M050	5m	118	1200658606	805000I03M040	4m
14	1200060454	804000I03M030	3m	49	1200062676	808000P19M050	5m	84	1200651126	804000K05M100	10m	119	1200658677	808000I02M010	1m
15	1200060469	804000S20M010	1m	50	1200062754	803000P82M0047	0.4m	85	1200651767	803000E52M050A	5m	120	1200658678	808000I02M020	2m
16	1200060470	804000S20M020	2m	51	1200062765	808000P19M020	2m	86	1200651778	804000E52M050A	5m	121	1200658679	808000I02M030	3m
17	1200060471	804000S20M0201 *	2m	52	1200062858	805000P12M100	10m	87	1200651857	804000E52M100A	10m	122	1200658680	808000I02M040	4m
18	1200060472	804000S20M030	3m	53	1200062869	804000P20M150	15m	88	1200652019	808000P19M100	10m	123	1200658681	808000I02M050	5m
19	1200060474	804000S20M050	5m	54	1200062969	805000I26M100	10m	89	1200655003	805000S26M050	5m	124	1200658682	808000I02M100	10m
20	1200060476	804000S20M100	10m	55	1200063017	804000P04M0083	0.8m	90	1200655009	805000S26M100	10m	125	1200658701	804000I03M010G	1m
21	1200060478	804000S20M150	15m	56	1200063035	805000P20M100	10m	91	1200655010	804000S20M150H	15m	126	1200658702	804000I03M020G	2m
22	1200060644	805000I03M030	3m	57	1200063041	805000P12M0033	0.3m	92	1200655025	805000I03M100G	10m	127	1200658703	804000I03M030G	3m
23	1200060645	805000I03M100	10m	58	1200063114	804000P04M0163	1.6m	93	1200655074	808000P19M060	6m	128	1200658704	804000I03M040G	4m
24	1200060715	805000P82M050	5m	59	1200063141	803000P12M0033	0.3m	94	1200656198	808000S19M010	1m	129	1200658705	804000I03M050G	5m
25	1200061240	803000P82M0507	5m	60	1200063182	804000S20M0501H	5m	95	1200656199	808000S19M020	2m	130	1200658706	804000I03M100G	10m
26	1200061559	803000I20M100	10m	61	1200063205	804000I03M060	6m	96	1200656200	808000S19M030	3m	131	1200658817	805000I26M010	1m
27	1200061620	804000E52M3001A	30m	62	1200063409	804000S20M1001 *	10m	97	1200656201	808000S19M050	5m	132	1200658972	808000S19M100	10m
28	1200061680	804000H69M050	5m	63	1200063562	804000I04M030	3m	98	1200658015	805000E63M020A	2m	133	1200659026	805000P82M1007	10m
29	1200061727	805000I26M050	5m	64	1200063569	803000S20M003	0.3m	99	1200658086	805000P12M020	2m	134	1200659049	805000P20M050	5m
30	1200061936	805000E63M050A	5m	65	1200063684	804000S20M2001 *	20m	100	1200658104	808000P19M150	15m	135	1200659060	804000I03M050Y	5m
31	1200061955	804000I03M200A	20m	66	1200063819	804000E52K0011A	100m	101	1200658221	804000I20M050	5m	136	1200659064	803000I03M050Y	5m
32	1200061956	804000I03M300A	30m	67	1200063824	805000I03M050G	5m	102	1200658230	805000S20M050	5m	137	1200659065	804000I03M100Y	10m
33	1200061957	804000I03M400A	40m	68	1200063859	804000S20M0501 *	5m	103	1200658236	808000E52M020	2m	138	1200659075	804000I03M020Y	2m
34	1200061970	804000I03M100A	10m	69	1200063913	805000P20M003	0.3m	104	1200658242	804000H69M300	30m	139	1200659085	805000I03M050Y	5m
35	1200062003	805000I03M050	5m	70	1200063993	804000S20M200	20m	105	1200658252	805000S26M020	2m	140	1200659090	805000I26M100Y	10m

NOTES:

* - Part No. with Yellow PVC overmolding

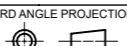
THIS DRAWING CONTAINS INFORMATION THAT IS PROPRIETARY TO MOLEX ELECTRONIC TECHNOLOGIES, LLC AND SHOULD NOT BE USED WITHOUT WRITTEN PERMISSION									
DIMENSION UNITS		SCALE		CURRENT REV DESC: REMOVED OBSOLETE PART NUMBER AS PER PCN#510807.					
mm		1:1		 CSE M12 XP AC FE STR XM SE UNSH PRODUCT CUSTOMER DRAWING					
GENERAL TOLERANCES (UNLESS SPECIFIED)									
ANGULAR TOL ± 1.0 °									
4 PLACES ±		EC NO: 726454							
3 PLACES ±		DRWN: LIKITV 2022/09/28							
2 PLACES ± 0.05		CHK'D: GGA 2022/11/30							
1 PLACE ± 0.3		APPR: GGA 2022/11/30							
0 PLACES ± 0.5		INITIAL REVISION:		DOCUMENT NUMBER		DOC TYPE		DOC PART	
DRAFT WHERE APPLICABLE MUST REMAIN WITHIN DIMENSIONS		THIRD ANGLE PROJECTION		DRAWING		SERIES		MATERIAL NUMBER	
				A3-SIZE		120065		SEE PART LIST	
						2016/01/12		1200658605	
						2016/04/08		PSD 000 A6	
								3 OF 4	

DOCUMENT STATUS	P1	RELEASE DATE	2022/11/30	11:33:45
-----------------	----	--------------	------------	----------

PART LIST

No.	Part No.	Engineering No.	Cable Length
141	1200659113	804000H12M050	5m
142	1200659116	805000I26M050Y	5m
143	1200659119	803000I03M020Y	2m
144	1200659175	808000S19M200H	20m
145	1200659177	804000I03M030Y	3m
146	1200659183	808000S19M150H	15m
147	1200659271	804000H12M100	10m
148	1200659371	805000I03M100Y	10m
149	1200659376	804000S20M350	35m
150	1200659390	803000S20M070	7m
151	1200659393	805000P12M050	5m
152	1200659558	803000I20M100Y	10m
153	1200659593	804000H12M020	2m
154	1200659621	804000I04M050	5m
155	1200659635	805000P20M300	30m
156	1200659767	804000H12M0209	2m
157	1200659768	804000H12M0309	3m
158	1200659769	804000H12M0509	5m
159	1200659770	804000H12M1009	10m
160	1200659989	805000S26M200	20m
161	1200659997	808000E52M100	10m
162	1200868439	808000S19M150	15m
163	1200651122	804000K05M030	3m
164	1200651367	805000K03M020	2m
165	1200651370	805000K03M050	5m
166	1200651373	805000K03M100	10m

THIS DRAWING CONTAINS INFORMATION THAT IS PROPRIETARY TO MOLEX ELECTRONIC TECHNOLOGIES, LLC AND SHOULD NOT BE USED WITHOUT WRITTEN PERMISSION										
DIMENSION UNITS mm	SCALE 1:1	CURRENT REV DESC: REMOVED OBSOLETE PART NUMBER AS PER PCN#510807.			molex					
GENERAL TOLERANCES (UNLESS SPECIFIED)		EC NO: 726454								CSE M12 XP AC FE STR XM SE UNSH
ANGULAR TOL ± 1.0 °		DRWN: LIKITV 2022/09/28			PRODUCT CUSTOMER DRAWING					
4 PLACES ±		CHK'D: GGA 2022/11/30			DOCUMENT NUMBER					
3 PLACES ±		APPR: GGA 2022/11/30			1200658605			DOC TYPE	DOC PART	REVISION
2 PLACES ± 0.05		INITIAL REVISION:			2016/01/12			PSD	000	A6
1 PLACE ± 0.3		DRWN: JMARSZALEK 2016/04/08			2016/04/08			SHEET NUMBER		
0 PLACES ± 0.5		APPR: RSILLER			A3-SIZE			MATERIAL NUMBER		CUSTOMER
DRAFT WHERE APPLICABLE MUST REMAIN WITHIN DIMENSIONS	THIRD ANGLE PROJECTION	DRAWING	SERIES	MATERIAL NUMBER	CUSTOMER	SHEET NUMBER				
		A3-SIZE	120065	SEE PART LIST	GENERAL MARKET	4 OF 4				

DOCUMENT STATUS	P1	RELEASE DATE	2022/11/30	11:33:45
-----------------	----	--------------	------------	----------

Table of length tolerances		
Over	Up to and including	Tolerance
0	305	+19
305	915	+45
915	1830	+56
1830	3660	+89
3660	7320	+165
7320	14640	+317
14640	30500	+610
30500	>	+2% of length

CHART 1

MOLEX PN	ENGINEERING No.	L [mm]
1200659593	804000H12M020	2000
1200659113	804000H12M050	5000
1200659271	804000H12M100	10000

VIEW FROM THE FRONT SIDE

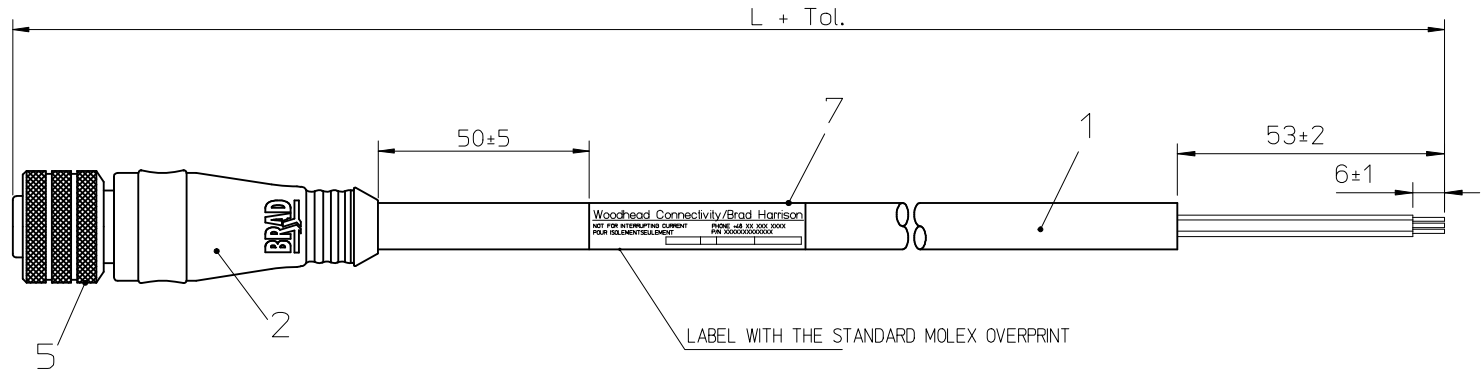
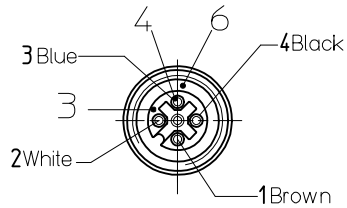

Notes:

- 1) Material: See Table
- 2) Finish: See Table
- 3) Cable: Cable 4x0.5 mm²

ENVIRONMENTAL:

- OPERATING TEMPERATURE: -25°C to +80°C
- VOLTAGE RATING: 250V
- AMPERAGE RATING: 4A
- PROTECTION: IP67

BILL OF MATERIALS:

ITEM	QTY.	DESCRIPTION	MATERIAL	FINISH
7	1	LABEL	VINYL	YELLOW/BLACK
6	1	GASKET	FPM	RED
5	1	M12 FE COUPLING NUT	BRASS	NICKEL PLATING
4	4	CONTACT	BRONZE	GOLD OVER NICKEL PLATING
3	1	INSERT FEMALE 4P AC	PUR	BLACK
2	-	OVERMOULD	PUR	BLACK
1	-	CABLE LSZO	PUR	BLACK

NEW PN ADDED EC NO: IPG2015-1290 DRW: MSTRASZKIEMI 2015/01/22 CHK: DFGAIK 2015/01/22 APPR: MIWASIECZKO 2015/01/30	DESCRIPTION B	QUALITY SYMBOLS	GENERAL TOLERANCES (UNLESS SPECIFIED) mm INCH 4 PLACES ± --- ± --- 3 PLACES ± --- ± --- 2 PLACES ± 0.05 ± --- 1 PLACE ± 0.3 ± --- 0 PLACE ± 0.5 ± --- ANGULAR ± --- ° DRAFT WHERE APPLICABLE MUST REMAIN WITHIN DIMENSIONS	DIMENSION STYLE	SCALE	DESIGN UNITS	THIRD ANGLE PROJECTION
				MM ONLY	---	METRIC	
				DRAWN BY DATE	CHECKED BY DATE	TITLE	
				APPROVED BY DATE			
				E JABLONSKA01 2013/09/30 MSZWAJKOWSKI 2013/09/30 MIWASIECZKO 2013/10/03	CSE M12 AC 4P FE STR PUR XXM UNISH SE		
				MATERIAL NO. SEE CHART 1	DOCUMENT NO. SD-120065-066	SHEET NO. 1 OF 1	
				THIS DRAWING CONTAINS INFORMATION THAT IS PROPRIETARY TO MOLEX INCORPORATED AND SHOULD NOT BE USED WITHOUT WRITTEN PERMISSION			