

**STRAIGHT PLUG CLAMP TYPE  
CABLE 6/75+93 .**

**R161.012.000**  
**SERIES N**

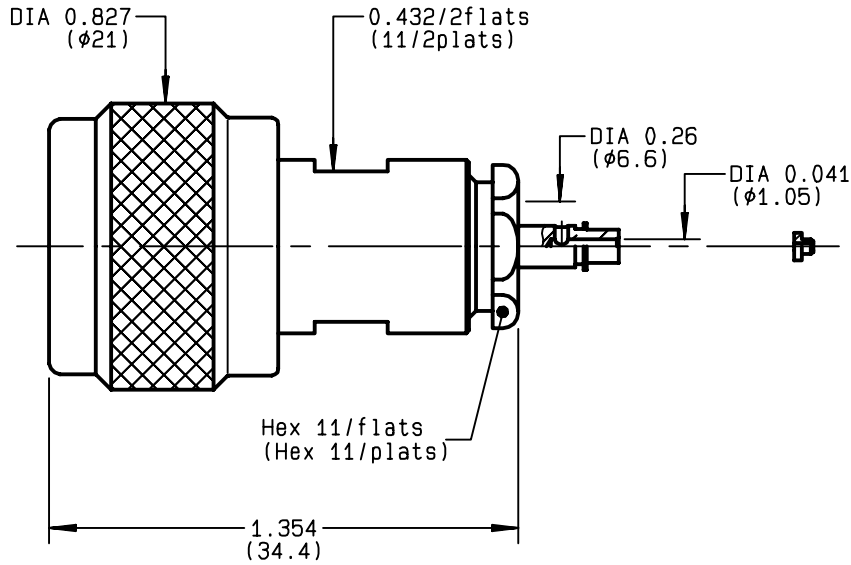

NOMINAL IMPEDANCE	<b>50</b> Ω	CABLES : <b>BICC T3304</b> <b>KX 6A</b> <b>RG 59</b> <b>RG 62</b> <b>RG 71</b>
FREQUENCY RANGE	<b>0-11</b> GHz	
TEMPERATURE RATING	<b>-55/+155</b> °C	
V.S.W.R	<b>NA</b> + x F(GHz)Maxi	
RF INSERTION LOSS	<b>0.048</b> √F(GHz) dB Maxi	
VOLTAGE RATING	<b>850</b> Veff Maxi	
DIELECTRIC WITHSTANDING VOLTAGE	<b>1500</b> Veff Mini	
INSULATION RESISTANCE	<b>5000</b> MΩMini	
HERMETIC SEAL	<b>NA</b> Atm.cm <sup>3</sup> /s	
LEAKAGE (pressurized only)	<b>NA</b>	
MECHANICAL DURABILITY	<b>500</b> Cycles	OTHERS CHARACTERISTICS
WEIGHT	<b>32.5</b> gr	CABLE RETENTION <b>200</b> N Mini
SPECIFICATION		CENTER CONTACT RETENTION
		Axial force - mating end <b>NA</b> N Mini
		Axial force - opposite end <b>27</b> N Mini
		Torque <b>NA</b> cm.N Mini
		RECOMMENDED TORQUES
		Mating <b>130</b> cm.N
		Panel nut <b>NA</b> cm.N
		Clamp nut <b>450</b> cm.N

CONNECTOR PARTS	MATERIALS	FINISH	(all values are given in micrometers)
BODY	BRASS	BBR 2	
OUTER CONTACT	BRASS	BBR 2	
CENTER CONTACT	BRASS	GOLD 0.5 OVER NICKEL 2	
INSULATOR	PTFE	-	
GASKET	SILICONE RUBBER	-	
OTHERS PIECES	BRASS	BBR 2	

ISSUE	CREATION DATE	FILE PART-NUMBER
<b>9809C02</b>	<b>27/06/1995</b>	<b>EPC 96-07</b>



*Connect to the future*

The information given here is subject to change without notice. Design changes may be in order to improve the product .

TRIQUES E.



**R161.012.000**

ISSUE 9809C02 SERIES N

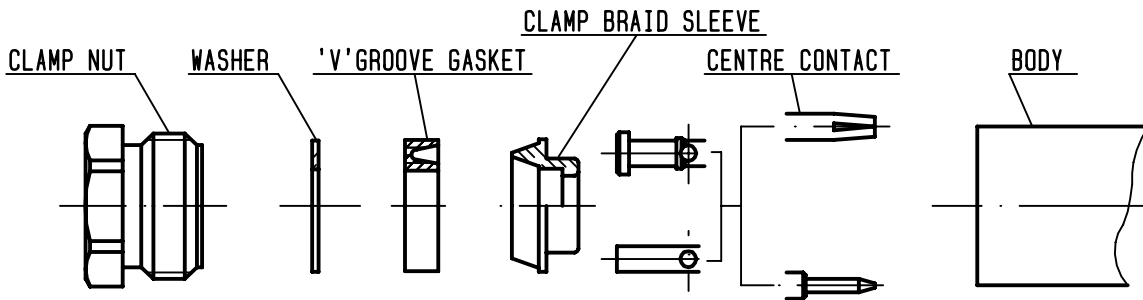

①

Strip the cable .

-  
-  
-  
-

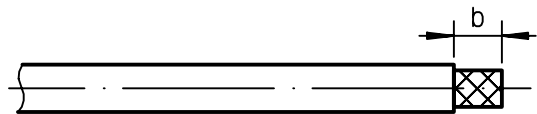

Stripping	a	b	c	d	e
inch	0.157	0.295	0	0	0.039
mm	4	7.5			1

②

Slide the clamp nut , the washer and the 'V'groove gasket onto the cable .  
 Slide clamp braid sleeve over braid .  
 Fold back braid and trim off surplus braid .  
 Trim back dielectric as shown .  
 -  
 NOTA: For air-space PE cables , "e" = 0 .  
 Introduce insulator onto dielectric cable .

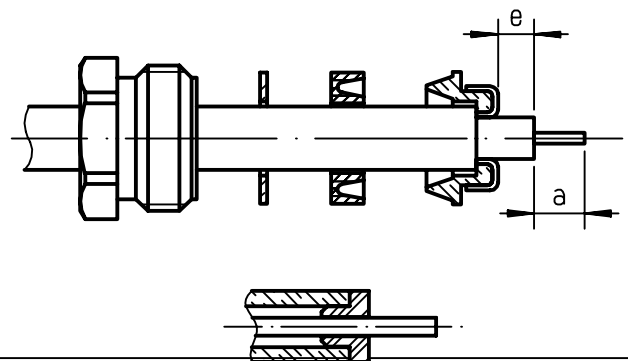

③

Solder the cable inner conductor into centre contact .

-  
-  
-  
-  
-

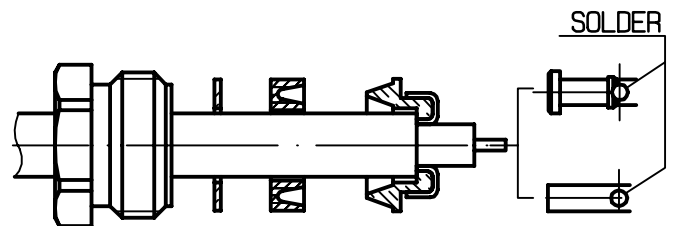

④

Screw sub-assembly into the connector body .  
 ( recommended coupling torque 39.83 in.lb )

-  
-

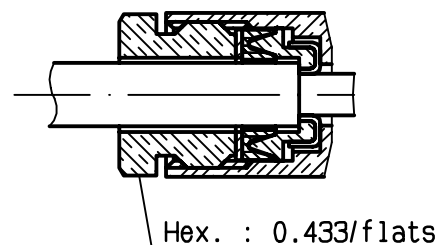

TRIQUES E.