

DATE	REV	ECN	APP'D. BY
06/12/19	A0	Released	AB
08/06/19	A1	11432	AB

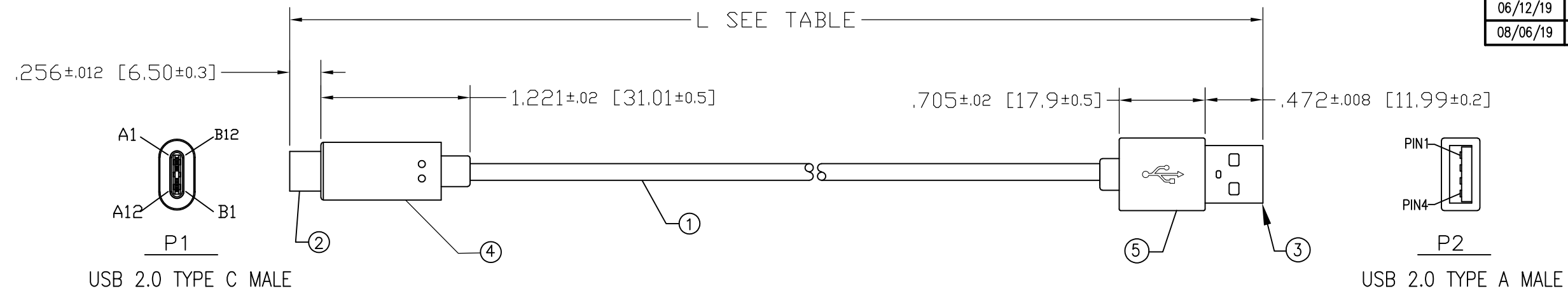

P/N Key:

SC-2CAKxxxM  
 Length  
 010 = 1 Meter  
 020 = 2 Meter

Notes:

- Cable:  
 USB 2.0 CABLE, UL STYLE 1  
 -28AWG 1 TWISTED PAIR  
 -26AWG X 2C  
 -OD 4.5mm  
 -JACKET BLACK,
- Connector P1:  
 USB 2.0 C MALE , GOLD FLASH ON CONTACTS, WITH PCB, BLACK INSULATOR  
 RESISTANCE 56K ohm
- Connector P2:  
 USB A MALE, GOLD FLASH ON CONTACTS, WHITE INSULATOR, SHORT THREE PIECES TYPE
- USB Type C Over-Molded PVC Color: Black
- USB Type A Over-Molded PVC Color: Black
- Electrical Test:  
 6.1. 100%Test(Open ,short ,Wire Map)
- Packaging: Each cable assembly to be individually bagged

PIN ASSIGNMENT			
P1		P2	
A4+B4+A9+B9	—	1 RED	26 AWG
A7	—	2 WHITE	
A6	—	3 GREEN	
A1+B1+A12+B12	—	4 BLACK	26AWG
SHIELD	—	SHIELD	

Example Parts Numbers

Meter	
P/N	Dim L
SC-2CAK010M	1000 mm ±30mm
SC-2CAK020M	2000 mm ±30mm

For Part Numbers Not Shown Follow Part Number Key Format

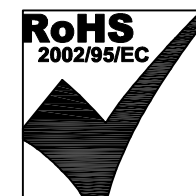

THIRD ANGLE PROJECTION
DO NOT SCALE DRAWING DRAWING IS SUBJECT TO CHANGE WITHOUT NOTICE
DIMENSIONS: INCHES [METRIC]
UNLESS OTHERWISE SPECIFIED TOLERANCES ARE ±.005 [0.13] ANGLES ARE ± 1°
SHEET NO. 1 OF 1

	11118 Susquehanna Trail South Glen Rock, PA 17327-9199 (717) 235-7512 <a href="http://www.stewartconnector.com">http://www.stewartconnector.com</a>	
	TITLE: Cable Assembly, USB 2.0, Type C/M – Type A/M, Black	
DRN BY: GWL	DATE: 05/30/19	
APPD BY: AB	DATE: 06/12/19	
DWG NO. CT999194	REV. A1	