

DONAU SLIM ENHANCED 11x15x3.0 mm SPEAKER

The 11 x 15 x 3.0 mm rectangular speaker is a high end miniature speaker specifically designed for portable devices and smartphones where high quality sound is required.

It delivers pure , uncolored sound reproduction in applications with small space.
Suitable for mono and stereo applications.

It offers a low resonance frequency of 800Hz in the 1cm³ back cavity.

The speaker's compound membrane has an additional stiffening plate - made from a unique, lightweight composite material - that provides inner damping and results in extremely low Total Harmonic Distortion (THD) values.



Features:

- Rectangular shape that measures only 11 x 15 x 3.0 mm
- Pure, uncolored sound reproduction
 - Flat, wideband frequency response
 - Lowest resonance frequency (800 Hz) in 1cm³ back cavity
- Clear music and voice reproduction
 - Unique compound membrane with additional stiffening plate of lightweight composite material for inner damping and low THD
- Extremely robust spring connector
- 100% in-line measurement of all specified acoustical and electrical parameters.
- Power handling up to 600mw.

2403 263 00301

Contents

1.	Theory of operation.....	3
2.	Mechanical Layout and Dimensions.....	4
2.1.	Main Dimensions.....	4
2.2.	Spring force	4
2.3.	PWB Layout	5
2.4.	Magnetic polarity	5
2.5.	Force layout.....	5
2.6.	Part Marking/Labeling.....	6
2.7.	Material List.....	7
3.	Electrical and Acoustical Specifications.....	8
3.1.	Frequency response	8
3.2.	Electro-Acoustic Parameters	9
3.3.	Power definition for life time test.....	9
3.4.	Measured Parameters.....	10
3.5.	Measurement setup	11
3.6.	Measurement adapter 1cm ³	11
4.	Environmental Conditions.....	12
4.1.	Storage.....	12
4.2.	Transportation.....	12
4.3.	Functionality.....	12
5.	Environmental tests	13
5.1.	Qualification tests.....	13
5.2.	Reliability tests	13
5.3.	Sample Size, Sequence	13
5.4.	Period of Shelf-Life	13
5.5.	Testing Procedures	13
6.	Related Documents	13
7.	Change History	18
8.	Disclaimer	18

**2403 263 00301**

1. Theory of operation

Donau Slim Enhanced 11x15x3.0 mm Speaker is an electro-dynamic transducer, designed to translate electrical analog signals into sound. The input signal is fed into a coil in a magnetic field, which is attached to a membrane. Through the principle of the electromagnetic force, the membrane is moved according to the contents of the input signal.

2403 263 00301

2. Mechanical Layout and Dimensions

2.1. Main Dimensions

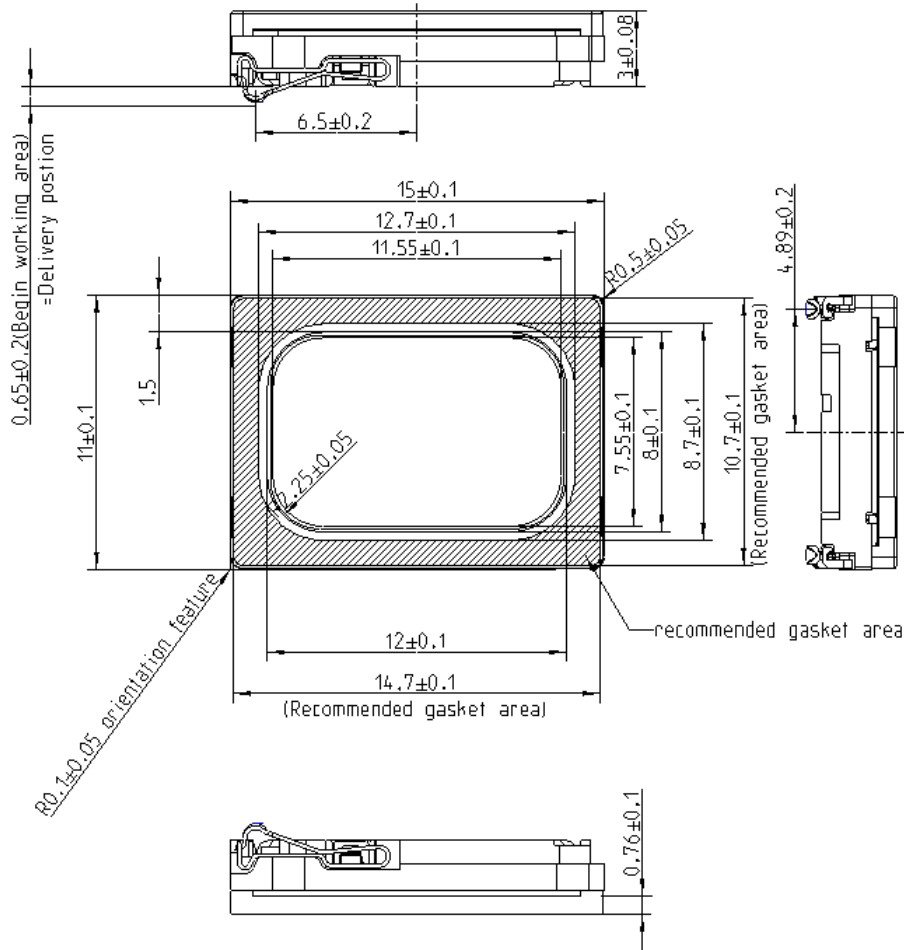

2.2. Spring force

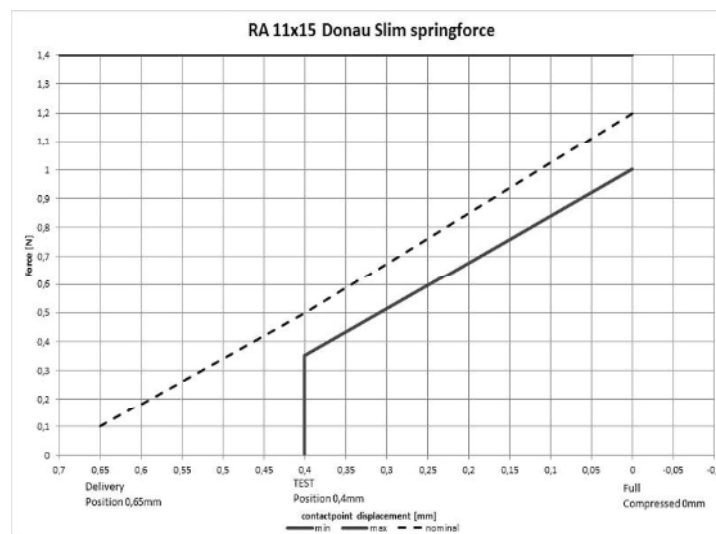

2403 263 00301

2.3. PWB Layout

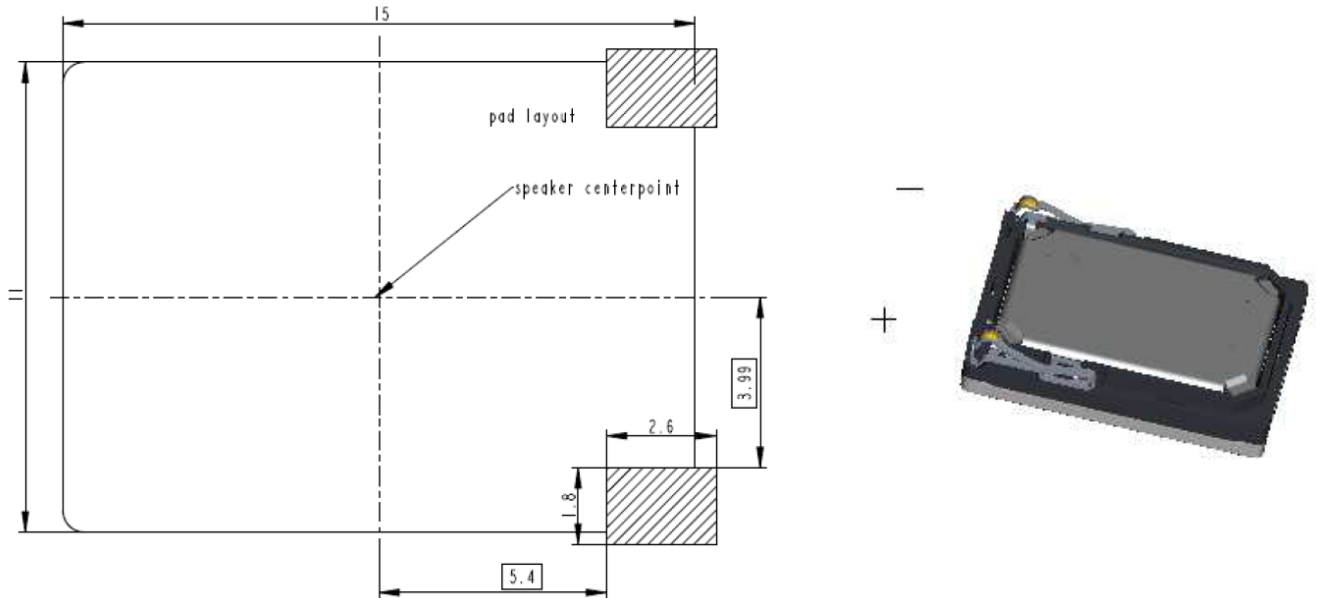

2.4. Magnetic polarity

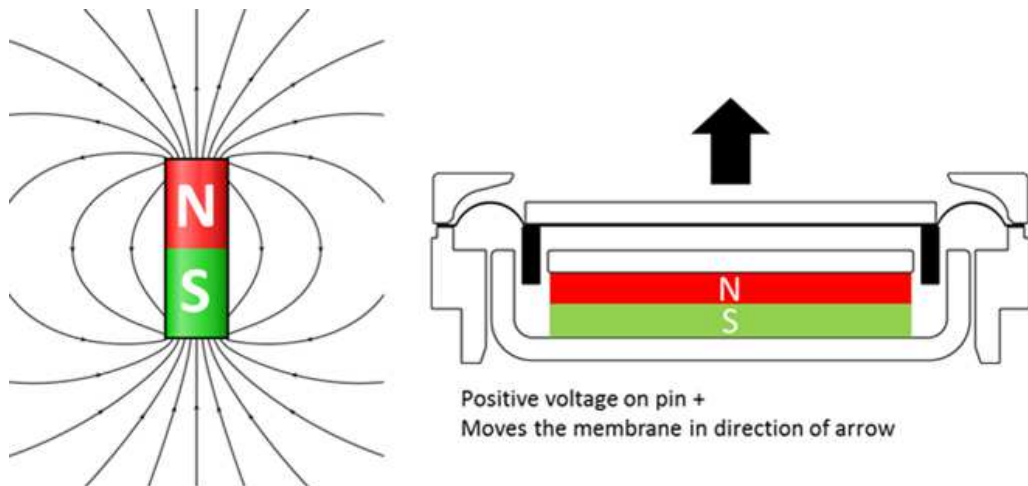

2.5. Force layout

STATICAL FORCES ON DIFFERENT STATES OF COMPONENT			
STATE	MIN. SURFACE OF PRESSURE [mm ²]	MAX. PERMANENT FORCE [N]	MAX. HANDLING FORCE [N]
FROM FRONT TO BACK	-	15	20
FROM SIDE 1 TO SIDE 3	3	10	15
FROM SIDE 2 TO SIDE4	10	10	15
TO POT	-	10	15
TO MEMBRANE	-	0	0
PULL FORCE OF YOKE	-	10	15
PULL OFF FORCE	-	10	15

2403 263 00301

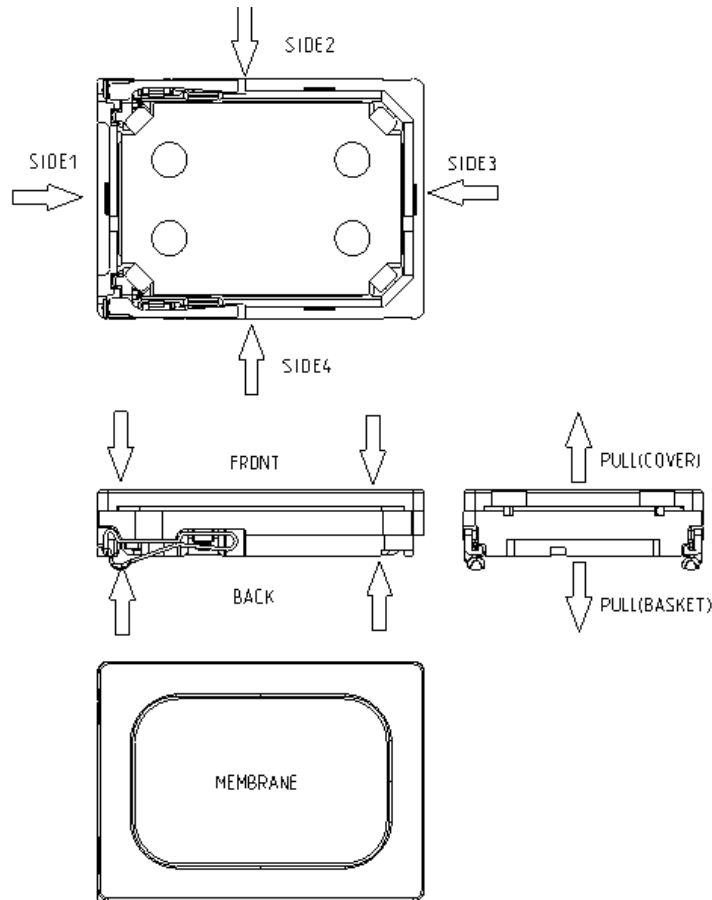

2.6. Part Marking/Labeling

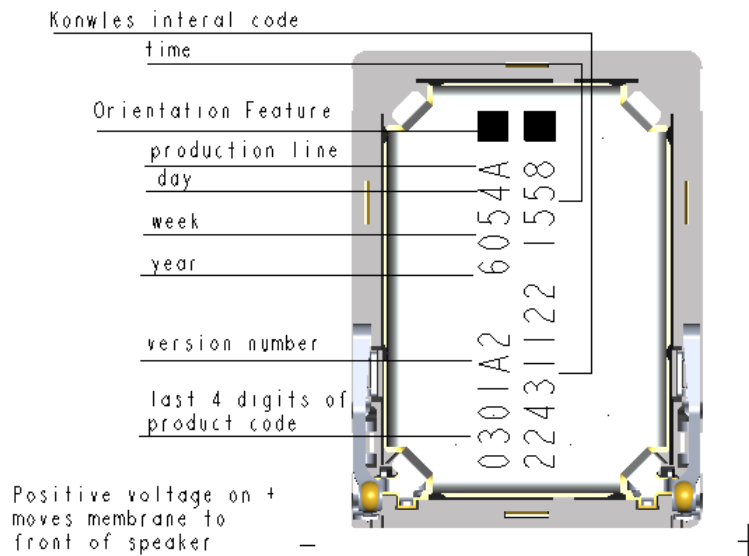

2403 263 00301

2.7. Material List

1. MATERIAL of BASKET: Polycarbonate
2. MATERIAL of MEMBRANE: Compound Foil
3. MATERIAL of POT: soft magnetic Iron
4. MATERIAL of MAGNET: Nd Fe B
5. MATERIAL of CONTACT CrNi-Steel, gold plated
6. MATERIAL of COVER: Polycarbonate
7. DIMENSION: 11x15x3.0mm
8. MASS: 1.4g

2403 263 00301

3. Electrical and Acoustical Specifications

3.1. Frequency response

Typical frequency response measured on baffle according to chapter 3.5 and 3.6
(distance d = 1cm calculated to 10cm, P= 600mW,1ccm)

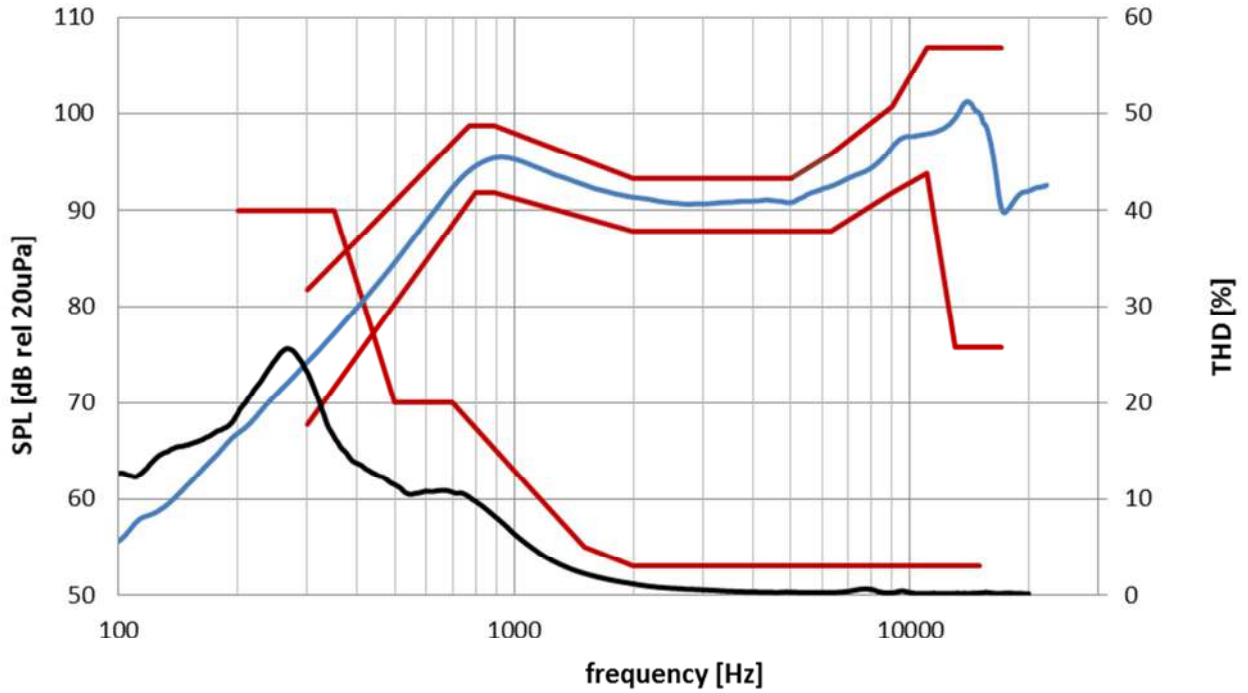

SPL limit:				THD limit	
FRES(Hz)	Min(dB)	FRES(Hz)	Max(dB)	FRES(Hz)	THD(%)
300	67.8	300	81.8	200	40
800	91.8	770	98.8	350	40
890	91.8	890	98.8	500	20
2000	87.8	2000	93.3	700	20
5000	87.8	5000	93.3	1500	5
6300	87.8	6300	95.8	2000	3
9000	91.8	9000	100.8	3000	3
11000	93.8	11000	106.8	15000	3
13000	75.8	13000	106.8		
17000	75.8	17000	106.8		

2403 263 00301

3.2. Electro-Acoustic Parameters

Loudspeaker mounted in 1cm³ measurement adapter acc. to 3.5

1. Rated impedance	Z:	8Ω
2. Voice coil DC resistance	R:	7.4Ω±10%
3. Resonance frequency	f ₀ :	800Hz±10%
4. Maximum linear excursion(peak to peak)	Xmax :	0.68mm
5. Characteristic sensitivity (@1W,1m)		
SPL average from 2kHz to 5kHz		73±2dB
SPL at 2kHz		73.5±2dB
7. THD		according chapter 3.1.
8. Rub & buzz		no audible R&B at 600mW
9. Power handling		600mW

All acoustic measurements at 23±2°C

10. Typical resonance frequency without back volume	F ₀	425Hz
---	----------------	-------

3.3. Power definition for life time test

- Loudspeaker mounted in Lifetime test device (closed Box 1ccm, open front)
- Signal: Pink Noise, High-pass filter: 12dB/Oct -3dB@800Hz, crest factor: 6dB, used for all operating lifetime tests

1. Max short term power Ambient temperature 70°C	1sec. ON, 1min. OFF, 60cycles	1200mW
2. Max continuous power Ambient temperature 70°C	1min. ON, 2min. OFF, 10cycles	800mW
3. Max. noise power Ambient temperature 70°C	(PHC continuous) 500h	600mW



2403 263 00301

3.4. Measured Parameters

3.4.1. Sensitivity

SPL is expressed in dB rel 20 μ Pa, computed according to IEC 268-5. Measurement set up and parameters according chapter 3.5. This test is performed for 100% of products in the production line.

3.4.2. Frequency response

Frequency response is measured according test set up in chapter 3.5 data sheet and checked against the tolerance window defined in chapter 3.1. This Test is performed for 100% of products in the production line.

3.4.3. Total harmonic distortion (THD)

Is measured according IEC 268-5 (2nd to 5th harmonics) and test set up in chapter 3.5. This test is performed for 100% of products in the production line.

3.4.4. Rub& Buzz

Rub & Buzz will be measured in the Inline-measuring device with a sinusoidal sweep. Rub and Buzz is defined as the maximum peak sound pressure in transmission range of the 5kHz high pass filter. This test is performed for 100% of products in the production line.

2403 263 00301

3.5. Measurement setup

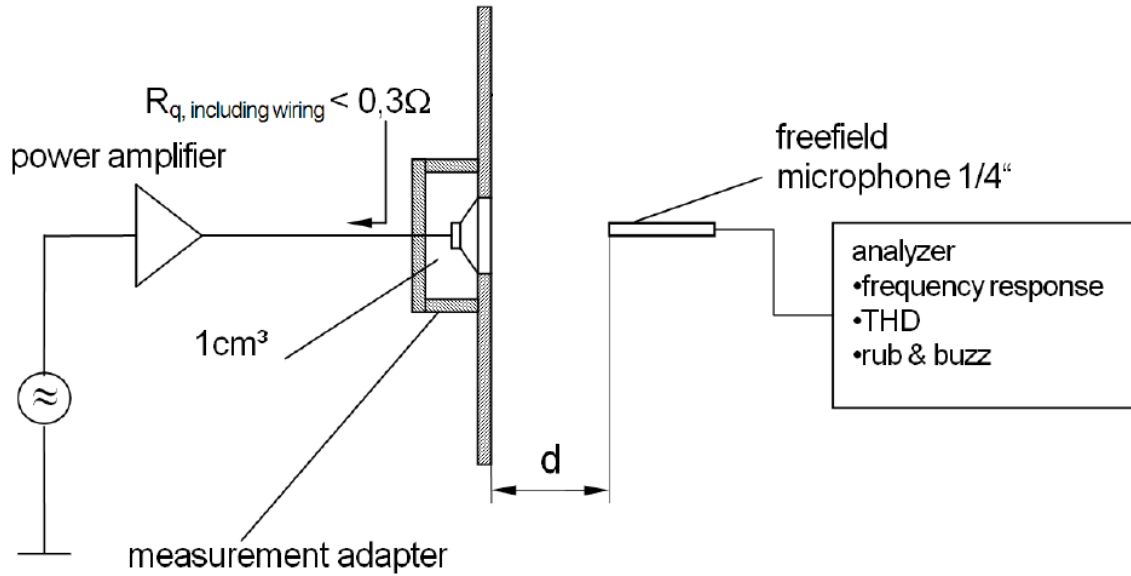

3.6. Measurement adapter 1cm³

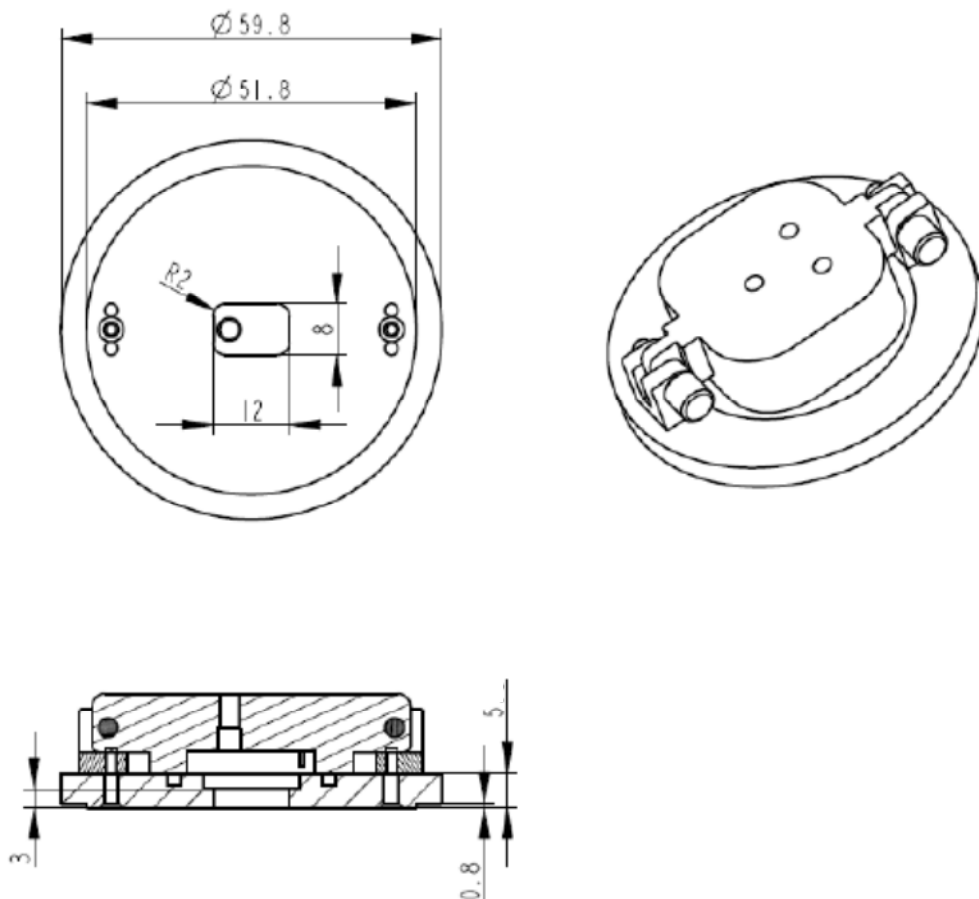

2403 263 00301

4. Environmental Conditions

4.1. Storage

The transducer fulfills the specified data after treatment according to the conditions of

ETS 300 019-2-1 Specification of environmental test: Storage
Test spec. T 1.2: Weather protected, not temperature controlled storage locations.

4.2. Transportation

The transducer fulfills the specified data after treatment according to the conditions of

ETS 300 019-2-2 Specification of environmental test: Transportation
Test Spec. T 2.3: Public Transportation

4.3. Functionality

The transducer fulfills the specified data after treatment according to the conditions of

ETS 300 019-2-5 Specification of environmental test: Ground vehicle installations
Test spec. T 5.1: Protected installation

ETS 300 019-2-7 Specification of environmental test: Portable and non-stationary use
Test spec. T 7.3E: Partly weather protected and non-weather protected locations.

5. Environmental tests

5.1. Qualification tests

According to our milestone plan (Product Creation Process), a complete qualification test will be done at design validation of products manufactured under serial conditions.

1x per year and product family a requalification takes place. The qualification process covers all tests described under 5.5 and a complete inspection.

5.2. Reliability tests

1x per month and product family samples are taken and submitted to tests described under 5.5.2

5.3. Sample Size, Sequence

Unless otherwise stated 20 arbitrary new samples will be used to perform each test for both, qualification and requalification test as described under 5.1 and 5.2.

5.4. Period of Shelf-Life

The period of shelf-life is 2 years.

5.5. Testing Procedures

5.5.1. Storage Tests

5.5.1.1. Cold Storage Test

Parameter	Test Method and Conditions	Duration	Evaluation Standard
Cold Storage (Ref. IEC 60068-2-1Ab)	-40°C rel. humidity not controlled	72h	Measurements after 2 hours recovery time. the module shall demonstrate normal performance as described in the specification

5.5.1.2. Dry heat storage

Parameter	Test Method and Conditions	Duration	Evaluation Standard
Dry Heat Storage (Ref. IEC 60068-2-2Bb)	+85°C rel. humidity not controlled	72h	Measurements after 2 hours recovery time. the module shall demonstrate normal performance as described in the specification

2403 263 00301

5.5.1.4. Change of temperature Test

Parameter	Test Method and Conditions	Duration	Evaluation Standard
Change of Temperature (Ref. IEC 60068-2-14Na)	-40°C/+85°C Transition time <3 min.	100 cycles. 30min each temperature	Measurements after 2 hours recovery time. the module shall demonstrate normal performance as described in the specification

5.5.1.5. Damp heat cyclic (modified)

Parameter	Test Method and Conditions	Duration	Evaluation Standard
Damp heat cyclic (modified) (Profile is modified from IEC 60068-2-30 Db: Damp heat, cyclic (12h + 12h).Variant 1)	Temperature cycling between +30°C and +65°C with 93 % relative humidity DUTs powered off	Duration 18 cycles, 1 cycle = 8h	Measurements after 2 hours recovery time. If reduced performance is noticed, DUTs are checked again after samples have been stored 24h at ambient conditions. the module shall demonstrate normal performance as described in the module specification.

2403 263 00301

5.5.2. Operating Tests

5.5.2.1. Cold usage Test

Parameter	Test Method and Conditions	Duration	Evaluation Standard
Cold usage Test (Ref. IEC 60068-2-1Ab)	-20°C rel. humidity not controlled signal acc. Chapter 3.3	72h	Measurements after 2 hours recovery time. The module shall demonstrate the normal performance after the test as described in the module specification.

5.5.2.2. Short-duration maximum power for speaker

Parameter	Test Method and Conditions	Duration	Evaluation Standard
Short-duration maximum power for speaker (Ref. IEC 268-5, IEC 268-1)	+70°C rel. humidity not controlled signal acc. Chapter 3.3 1sec on / 1 min off, for 60 times	72h	Measurements after 2 hours recovery time. The module shall demonstrate the normal performance after the test as described in the module specification.

5.5.2.3. Long-duration maximum power for speaker

Parameter	Test Method and Conditions	Duration	Evaluation Standard
Long-duration maximum power for speaker (Ref. IEC 268-5, IEC 268-1)	+70°C rel. signal acc. Chapter 3.3. 1min on / 2 min off, for 10 times	0.5h	Measurements after 2 hours recovery time. The module shall demonstrate the normal performance after the test as described in the module specification.

5.5.2.4. Long term power lifetime test for speaker

Parameter	Test Method and Conditions	Duration	Evaluation Standard
Long term power lifetime test for speaker (Ref. IEC 268-5, IEC 268-1)	+70°C rel. signal acc. Chapter 3.3	500h	Measurements after 2 hours recovery time. The module shall demonstrate the normal performance after the test as described in the module specification.

2403 263 00301

5.5.3. Free fall durability

Parameter	Test Method and Conditions	Duration	Evaluation Standard
Free fall durability (Ref. IEC 60068-2-31)	40 drops with various specified drop orientations @ drop height that represents 1.5m free fall(calibrated by measured impact speed) on concrete surface.	Two drops on each side (2x6) One drop on each edge (1x12) Two drops on each corner (2x8) (40 drops in total)	After the test, the module shall demonstrate normal performance as described in the module specification.

5.5.4. Free fall repeated

Parameter	Test Method and Conditions	Duration	Evaluation Standard
Free fall repeated (Ref. IEC 60068-2-31)	300 drops @ 1.0m drop height.	300 drops, 1m	After the test, the module shall demons described in the module specification.

5.5.5. Contact spring durability

Parameter	Test Method and Conditions	Duration	Evaluation Standard
Contact spring durability	6000 compression cycles on spring connector in specified working area (from minimum to maximum working positions) according to the module mechanical drawing, and measure the spring retention force during / after cyclic test. Measurement cycle speed 10mm / minute , Normal compression cycle speed 100mm / minute	6000 cycles	After 6000 cycles, spring retention force must be <ol style="list-style-type: none"> 1. Equal or higher than specified force in minimum working position 2. Equal or lower than specified force in maximum working position

2403 263 00301

5.5.6. Nitric acid test for spring/pad connectors

Parameter	Test Method and Conditions	Duration	Evaluation Standard
Nitric acid test for spring/pad connectors (REF. ISO 14647:2000)	Nitric acid (HNO ₃) 2hour, concentration: 69±2%, (1.39 to 1.42 g/cm ³). 125°C storage 0.5hour.	30min+2hour+30min+15min	After nitric acid test, score 1 module is accepted with actions and follow-up. No score 2 is allowed

5.5.7. Combined environments

Parameter	Test Method and Conditions	Duration	Evaluation Standard
Combined environments	Test procedure: 1. Change of temperature 50 cycles, -40/+85°C 2. Free fall repeated 50 drops @ 1.0m 3. Damp heat cyclic 1 cycle 8h, 18 cycles (6 days) 4. Free fall repeated 50 drops @ 1.0m	50cycles+50drops+18cycles+50 drops	After the test, the module shall demonstrate normal performance as described in the module specification.

6. Related Documents

- IEC 268-5** Sound System equipment
Part 5: Loudspeaker
- IEC 68-2** Environmental testing
- EN 60068-2** Environmental testing
- ISO 2859 - 1** Sampling procedures for inspection by attributes
Part 1: Sampling plans indexed by acceptable quality level (AQL) for lot-by-lot inspection
- ISO 3951** Sampling procedures and charts for inspection by variables for percent defectives.
- ETS 300 019-2-1** Specification of environmental test: Storage
Test spec. T 1.2: Weather protected, not temperature controlled storage locations
- ETS 300 019-2-2** Specification of environmental test: Transportation
Test spec. T 2.3: Public Transportation
- ETS 300 019-2-5** Specification of environmental test: Ground vehicle installations
Test spec. T 5.1: Protected installation
- ETS 300 019-2-7** Specification of environmental test: Portable and non-stationary use
Test spec. T 7.3E: Partly weather protected and non-weather protected locations

2403 263 00301

7. Change History

Status	Version	Date	ECR	Comment / Changes	Initials of owner
Draft	0.0	06.05.14		First Release	
Draft	0.1	17.06.14		Change the marking and update to V1.4 basket	Alice
Draft	0.2	18.11.14		Update to the latest Knowles logo	Alice
Draft	0.3	05.12.14		Adjust the dimension	Alice
Release	A	08.01.15		First release	AX

8. Disclaimer

Stresses above the Absolute Maximum Ratings may cause permanent damage to the device. These are stress ratings only. The device may not function when operated at these or any other conditions beyond those indicated under “Electrical and Acoustical Specifications”. Exposure beyond those indicated under “Electrical and Acoustical Specifications” for extended periods may affect device reliability.

This product is not qualified for use in automotive applications

Frequency range for Telekom use

The information contained in this literature is based on our experience to date and is believed to be reliable and it is subject to change without notice. It is intended as a guide for use by persons having technical skill at their own discretion and risk. We do not guarantee favorable results or assume any liability in connection with its use. Dimensions contained herein are for reference purposes only. For specific dimensional requirements consult factory. This publication is not to be taken as a license to operate under, or recommendation to infringe any existing patents. This supersedes and voids all previous literature.