

13.56 MHz Vicinity Badges

Description

The Vicinity Transponder Badge from Texas Instruments is compliant with the ISO/IEC 15693 global standard for contactless integrated circuit cards that allows interoperability of products from multiple manufacturers operating at 13.56MHz. The badge is based on TI's Tag-it™ Smart Label technology. With a user memory of 2K bits organized in 64 blocks, the 13.56MHz badge enables advanced solutions for the access control market. The enhanced data capacity makes it easy

to handle new solutions such as biometrics authentication and advanced levels of encryption. Data written and stored on the badge, independent from a host system, means that employees carry vital information like authorization codes, certification or emergency medical histories. With TI's factory-programmed ID code, it's virtually impossible to forge or duplicate a badge, providing the assurance that no two badges - or people - anywhere in the world will be misidentified. Yet with in-the-field programmability,

additional data like time stamps or new identification and access codes can be created and updated on-the-fly.

The badge is available in two versions (with/without magnetic stripe) and can be easily customized and personalized using standard thermal transfer printers. Where the card needs to be used with a clip, a hole can be punched in the specified area (see drawing). Additional options including encrypted custom data programming and slot punching will be available.

Key features:

- ISO/IEC 15693 compliant
- 13.56MHz Operating Frequency
- Read/Write capability with data locking option
- 2k bit user memory
- Simultaneous Identification



TI-RFid 13.56 MHz Vicinity badges (print examples)

Specifications:

Part Number:	RI-TH1-CB2A	RI-TH1-CB3A (w/ magnetic stripe)
Supported Standard	ISO 15693 - Vicinity Cards	
Operating frequency	13.56 MHz	
Typ. required activation field strength read (at +25 °C)	99 dB A/m	
Typ. required activation field strength write (at +25 °C)	102 dB A/m	
Factory programmed Read Only Number	64 bits	
Memory (user programmable)	2k bits organized in 64 x 32 bit blocks	
Typical programming cycles (at +25 °C)	100,000	
Data retention time (at +25 °C)	> 10 years	
Simultaneous Identification of Tags	Up to 50 tags per second (reader/antenna dependent)	
Product Identifier 3mm from the edge, TI Logo = 4 digit number (2 mm x 8 mm)	020x	030x
Magnetic Stripe	-----	3 Tracks, High coercivity (according ISO 7811)
Dimensions	85.6 mm x 54 mm x 0.76mm (according ISO 7810)	
Weight	5 grams	
Case material	PVC (Polyvinylchloride), white	
Surface finish	Glossy	
Printability	Thermal Transfer (Dye Sublimation preferred), Silkscreen, Tamp on (Pad on)	
Operating temperature	- 25 °C to +50 °C (according to ISO 7810)	
Storage temperature	- 25 °C to +50 °C (according to ISO 7810)	
Packing quantity	250 badges	
Additional Documentation: "Memory Organization and Supported Command Set"	11-09-21-052	

Note: For highest possible read-out coverage we recommend to operate readers at a modulation depth of 20% or higher

RI-TH1-CB2A

- A - Product Identifier
- B - Punchable area
- C - Punch area orientation marks printed on card (crosshair 1mm x 1mm)
- D - Example for punch slot according ISO15693

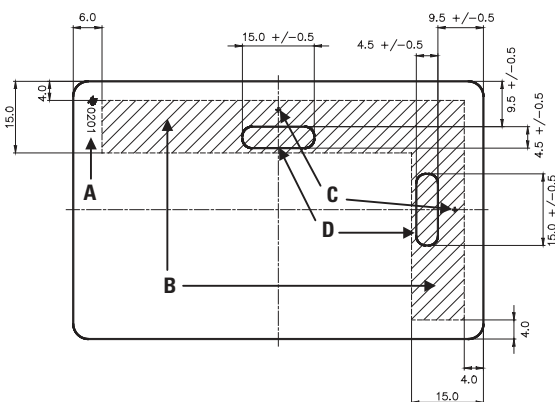

RI-TH1-CB3A

- A - Product Identifier
- B - Punchable area
- C - Punch area orientation marks printed on card (crosshair 1mm x 1mm)
- D - Example for punch slot according ISO15693
- E - Magnetic Stripe

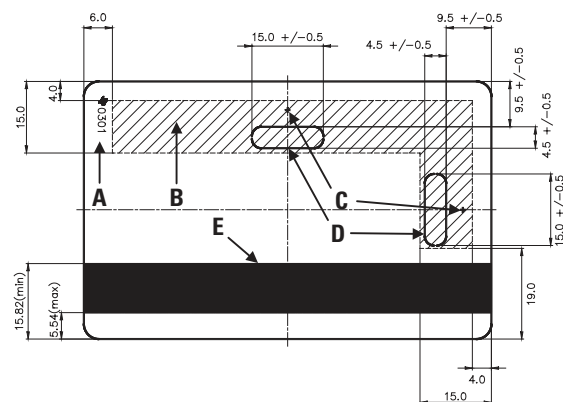

For more information, contact the sales office or distributor nearest you. This contact information, and the most up-to-date specifications for this data sheet can be found on our website at: <http://www.ti-rfid.com>

Texas Instruments reserves the right to change its products and services at any time without notice. TI provides customer assistance in various technical areas, but does not have full access to data concerning the uses and applications of customers products. Therefore, TI assumes no responsibility for customer product design or for infringement of patents and/or the rights of third parties, which may result from assistance provided by TI.