

ATLANTIC VERSION TERMINATOR INTERFACE ADAPTER	PART NUMBER	REVISION	DESCRIPTION	FEED TYPE	APPLICATOR STYLE CONVERSION CHART						
					CONVERT TO	PART NUMBERS REQUIRED					
	2266016-1	A	FINE CRIMP HEIGHT ADJUST	MECHANICAL	PNEUMATIC FEED	2119950-1	1338685-1	5-18022-5	2119641-1	2119799-1	2063440-1
	2266016-2	A	FINE CRIMP HEIGHT ADJUST	PNEUMATIC	SERVO LATCH PLATE	2119951-1	-	8-2266016-5	1901094-3	1-1752354-8	2168400-6 (QUANTITY 2)
					SMART APPLICATOR	2161326-1	-	8-2266016-4	-	-	-
					MECHANICAL FEED	2119949-1	1338685-1	5-18022-5	2119653-1	-	-
	2266016-5	A	FINE CRIMP HEIGHT ADJUST	SERVO LATCH PLATE	SERVO LATCH PLATE	2119951-1	-	8-2266016-5	1901094-3	1-1752354-8	2168400-6 (QUANTITY 2)
					SMART APPLICATOR	2161326-1	-	8-2266016-4	-	-	-
	2266016-6	A	NON-CRIMP HEIGHT ADJUST	SERVO LATCH PLATE	MECHANICAL FEED	2119949-1	1338685-1	5-18022-5	2119653-1	-	-
PNEUMATIC FEED					2119950-1	1338685-1	5-18022-5	2119641-1	2119799-1	2063440-1	
2266016-7	A	FINE CRIMP HEIGHT ADJUST	NONE	-	-	-	-	-	-	-	
7-2266016-7	A	CRIMP TOOLING KIT	-	-	-	-	-	-	-	-	

APPLICATOR DATA		
CRIMP WIRE	SIZE	TYPE
WIRE	1.07 mm [.042]	F
INSUL	2.03 mm [.080]	F

APPLICATOR INSTRUCTIONS 408-10389

TERMINAL DATA: ALEX TERMINAL		TE CRIMP SPECIFICATION	
TERMINAL NAME: .165 MALE CRIMP TERMINAL			
WIRE STRIP LENGTH	INSULATION DIAMETER RANGE		
2.56-3.22 mm [.101-.127 IN]	∅ 1.78 mm MAX [.070 IN MAX]		
TERMINAL APPLICATION SPECIFICATION	NONE		
TERMINALS APPLIED			
TE TERMINAL	ALEX TERMINAL	TE TERMINAL	ALEX TERMINAL
2113365-1	4257T1	2113365-3	4257T-xGF
2113365-2	4257T1-xGC		

WIRE SIZE	CRIMP HEIGHT mm [INCH]	CRIMP HEIGHT REFERENCE SETTING
22 AWG	0.90 +/- 0.05 [.035 +/- .002]	7.7
24 AWG	0.82 +/- 0.05 [.032 +/- .002]	8.5
26 AWG	0.73 +/- 0.05 [.029 +/- .002]	9.5
28 AWG	0.69 +/- 0.05 [.027 +/- .002]	9.9

- 1 RECOMMENDED SPARE PARTS
- 2 GREASE BEARING SURFACES LIGHTLY
- 3. LUBRICATE DAILY PER THE APPLICATOR INSTRUCTION SHEET SUPPLIED WITH THE APPLICATOR.
- 4 APPLICATOR SPECIFIC DATA TO BE ENTERED INTO BLANK MEMORY CHIP AT ASSEMBLY. SEE BELOW FOR PART NUMBER:  
 MECHANICAL FEED WITH "SMART APPLICATOR" CONVERSION: 8-2266016-4  
 PNEUMATIC FEED WITH "SMART APPLICATOR" CONVERSION: 8-2266016-4  
 SERVO FEED WITH "FINE CRIMP HEIGHT ADJUST": 8-2266016-5  
 SERVO FEED WITH "NON-CRIMP HEIGHT ADJUST": 8-2266016-6
- 5. ADJUSTMENT OF THE STRIPPER MAY BE REQUIRED WHEN MOVING THE APPLICATOR BETWEEN BENCH AND LEADMAKER APPLICATIONS.
- 6 APPLY PART NUMBER 1-23419-5 LOCTITE TO THREADS OF ITEMS 62, 180 & 242. FOR -6 ONLY APPLY PART NUMBER 1-23419-5 LOCTITE TO THREADS OF ITEMS 37, 180 & 242.
- 7 GREASE THREADS, GROOVE AND O-RING ON ITEMS 35 & 252.
- 8 MAGNET, ITEM 166 MUST BE ORIENTED CORRECTLY IN ORDER TO PROPERLY ACTUATE THE COUNTER.
- 9 CRIMP HEIGHT REFERENCE SETTING WAS THE SETTING USED WHEN THE APPLICATOR WAS QUALIFIED AT THE FACTORY. ADJUSTMENT MAY BE NECESSARY WHEN RUNNING APPLICATOR IN THE FIELD.
- 10 SPARE FEED CAM STORAGE LOCATION REFER TO INSTRUCTION SHEET FOR ADDITIONAL INFORMATION.
- 11 TO CONVERT THE APPLICATOR TO A NON-CARRIER CUTTING STYLE, REMOVE ITEM 13 AND ATTACH TO THE LOCATION ON THE BACK SIDE OF THE HOUSING. REFER TO INSTRUCTION SHEET FOR ADDITIONAL INFORMATION.
- 12 WHEN ASSEMBLING A NON CRIMP HEIGHT ADJUST APPLICATOR (-6) USE SHIMS FROM ITEM 260 TO ACHIEVE A NOMINAL SHIM HEIGHT OF 4.90.
- 13 TERMINAL LUBRICANT IS RECOMMENDED.

\*WARNING  
 ON INSTALLATION, SET WIRE DISC, ITEM 40 TO LARGEST WIRE SIZE SETTING. USE OF SETTINGS BELOW MINIMUM REQUIRED CRIMP HEIGHT SETTING WILL CAUSE DAMAGE TO CRIMP TOOLING.

-	-	1	-	-	-	2119957-2	APPLICATOR SHIM PACK	260
-	1	-	1	1	1	8-21084-0	O-RING, .676 ID, .070 DIA. MAT.	252
-	-	-	-	1	-	2119640-1	PUSH ROD, AIR FEED	250
-	-	-	-	1	-	2079988-1	BUSHING, LCH5-12, MISUMI	249
-	-	-	-	1	-	2119641-1	FEED CAM, AIR FEED	248
-	1	-	1	1	1	2119798-1	DETENT PIN	247
-	1	-	1	1	1	1-22279-3	SPRING, COMPRESSION	246
-	-	1	-	-	-	2119758-1	RAM, AMP STYLE, SIDE FEED, NON-ADJ.	245
-	1	1	1	1	1	2119082-8	CAM, SNAIL, INSULATION ADJUSTMENT	244
-77	-7	-6	-5	-2	-1	PART NO	DESCRIPTION	ITEM NO

ATLANTIC VERSION  
 Shown on sheets 1 of 4 & 2 of 4  
 (Pacific version shown on sheets 3 of 4 & 4 of 4)

SET UP GAUGE	LOC	DIST	REVISIONS			
2119599-1	A	66	REV	DATE	BY	APPV
			1	DEVELOPMENT	06AUG2013	YY UG
			A	RELEASED	13SEP2013	YY UG

-	1	1	1	1	1	2079764-1	WASHER, WAVE SPRING, CREST-TO-CREST	243
-	1	1	1	1	1	2119083-1	RETAINER, INSULATION DIAL	242
-	1	1	1	1	1	7-18023-7	SCR, SKT HD CAP M3 X 4.0	241
-	-	2	2	-	-	2168400-6	SHCS, LOW HEAD, RoHS, M5 X 16	240
-	-	-	-	-	1	2119580-1	MECHANICAL FEED ASSEMBLY	239
-	-	-	-	-	1	2063440-1	AIR FEED MODULE	238
-	-	1	1	-	-	2119740-2	TAG, IDENTIFICATION	213
-	-	1	1	-	-	1901094-3	SPACER, FEEDER	198
-	1	1	1	1	1	1-1752354-8	STANDOFF, HOLD-DOWN	180
-	1	1	1	1	1	6-993111-6	PIN, SLOTTED SPRING 3.0 X 14.0	177
-	1	1	1	1	1	8-22280-7	SPRING, COMPRESSION	176
-	1	1	1	1	1	1752353-2	GUIDE PIN, HOLDDOWN	175
-	1	1	1	1	1	1901680-2	GUIDE PIN, HOLDDOWN	174
-	-	-	-	2	-	21045-3	RING, RETAIN, EXTERN, 3/16 CRESCENT	172
-	1	1	1	1	1	994969-1	MAGNET, RARE EARTH HIGH ENERGY	166
-	REF	REF	REF	REF	REF	994970-2	COUNTER, MAGNETIC	164
-	-	-	-	1	-	240638-1	SPRING, FEED FINGER	163
-	-	-	-	1	-	3-23627-7	PIN, RETAIN, GRVD, 3/16 X .854	137
-	-	-	-	1	-	2119799-1	HOLDER, FEED FINGER, AF	136
-	-	REF	REF	-	-	SEE NOTE 4	MEMORY CHIP, PROGRAMMED	135
-	-	1	1	-	-	1633743-1	SERVO FEED LATCH ASM	133
-	1	1	1	1	1	1-18028-2	WASHER, FLAT, REG M4	119
-	-	REF	REF	-	-	2119944-1	FEED FINGER ASSEMBLY,SF	117
-	1	1	1	1	1	2119955-1	ASSY, LUBRICATOR, SIDE FEED	113
-	1	1	1	1	1	455888-5	SPACER, CRIMPER	82
-	1	1	1	1	1	5-547505-2	SPRING, COMPRESSION	77
-	1	1	1	1	1	854769-4	HOLDER, INS	74
-	1	1	1	1	1	2119956-1	DOCUMENTATION PACKAGE	71
-	1	-	-	1	1	2119740-1	TAG, IDENTIFICATION	67
-	2	2	2	2	2	2168078-1	SCREW, DRIVE, RH, RoHS, 2 x .188	66
-	1	-	1	1	1	2119793-1	LIMITER, ADJUSTMENT BOLT	63
-	3	-	3	3	3	992763-5	SCR, SET, SOC, CONE POINT, M3 x 4.0	62
-	1	1	1	1	1	2079383-4	SCR, BHSC, RoHS (M4 X 8)	60
-	-	-	-	1	1	5-18022-5	SCR, HEX HD CAP, M4 X 6.0	59
-	1	1	1	1	1	21028-2	PIN, SLOTTED SPRING .062 X .250	58
-	-	-	-	1	1	1338685-1	PAWL, FEED	56
-	4	4	4	4	4	2168400-1	SHCS, LOW HEAD, RoHS, M4 X 12	54
-	1	1	1	1	1	1-5018030-0	NUT, HEX, REG, RoHS, M3.5	52
-	1	1	1	1	1	1901681-1	HOLDDOWN, TERMINAL	51
-	-	-	-	1	2	18023-9	SCR, SKT HD CAP M4 X 6.0	49
-	-	-	-	-	1	2119652-1	FEED CAM, PRE FEED	48
-	-	-	-	-	1	2119653-1	FEED CAM, POST FEED	47
-	1	1	1	1	1	2119656-9	APPLICATOR BASIC ASSEMBLY, SF	46
-	1	-	1	1	1	2119370-1	RAM, AMP STYLE, SIDE FEED	44
-	1	1	1	1	1	2079383-7	SCR, BHSC, RoHS (M8 X 25)	41
-	1	-	1	1	1	2119645-1	DISC, NUMBERED FA WIRE ADJUSTMENT	40
-	1	-	1	1	1	2119957-1	APPLICATOR SHIM PACK	39
-	1	1	1	1	1	2119644-1	RAM WASHER, PRECISION	38
-	1	1	1	1	1	2119085-1	FA HEAD, ATLANTIC STYLE	37
-	1	-	1	1	1	2119092-1	BOLT, ADJUSTMENT	35
-	1	1	1	1	1	2-1752356-0	SUPPORT, TERMINAL	34
-	2	2	2	2	2	2079383-5	SCR, BHSC, RoHS (M4 X 20)	33
-	1	1	1	1	1	2161328-1	HEX HEAD, FLANGED, M5 x 8mm LONG	32
-	1	1	1	1	1	1320908-3	SPACER, STRIP GUIDE	30
-	1	1	1	1	1	2119959-1	ASSEMBLY, STRIP GUIDE	29
-	1	1	1	1	1	455888-3	SPACER, CRIMPER	28
-	1	1	1	1	1	1320928-2	STRIP GUIDE	24
-	1	1	1	1	1	2168083-2	SCR, SKT HD CAP, RoHS, M4 X 8.0	21
-	1	1	1	1	1	1-18028-2	WASHER, FLAT, REG M4	20
-	1	1	1	1	1	2119533-1	STRIPPER, SIDE FEED	19
-	1	1	1	1	1	2119806-1	INSERT, SHEAR	13
-	1	1	1	1	1	3-22280-3	SPRING, COMPRESSION	12
-	1	1	1	1	1	1-356885-4	STOP, SHEAR	11
-	1	1	1	1	1	2119805-1	SHEAR HOLDER, FRONT	10
-	1	1	1	1	1	1633861-1	SHEAR, FLOATING	9
-	1	1	1	1	1	1633916-5	ANVIL, COMBINATION	8
-	-	-	-	-	-	-	-	7
-	-	-	-	-	-	-	-	6
-	1	1	1	1	1	2119780-4	DEPRESSOR, SHEAR	5
-	1	1	1	1	1	1-238011-7	BLOCK, CRIMPER SPACER	4
-	1	1	1	1	1	3-1633962-8	CRIMPER, INSULATION F PREMIUM	3
-	-	-	-	-	-	-	-	2
-	1	1	1	1	1	4-1633713-8	CRIMPER, WIRE PREMIUM	1
-77	-7	-6	-5	-2	-1	PART NO	DESCRIPTION	ITEM NO

DIMENSIONS:		TOLERANCES UNLESS OTHERWISE SPECIFIED:		MATERIAL:		FINISH:		WEIGHT:		SCALE:	
mm	0 PLC ±.5	1 PLC ±0.5	2 PLC ±0.13	3 PLC ±0.013	4 PLC ±0.001	ANGLES ±.5	FINISH	-	-	-	1:2

Customer Accessible Production Drawing

LOC		DIST		REVISIONS			
A	66	P	LTM	DESCRIPTION	DATE	OWN	APVD
		-		SEE SHEET 1			

### FEED TYPE MECHANICAL



### PNEUMATIC

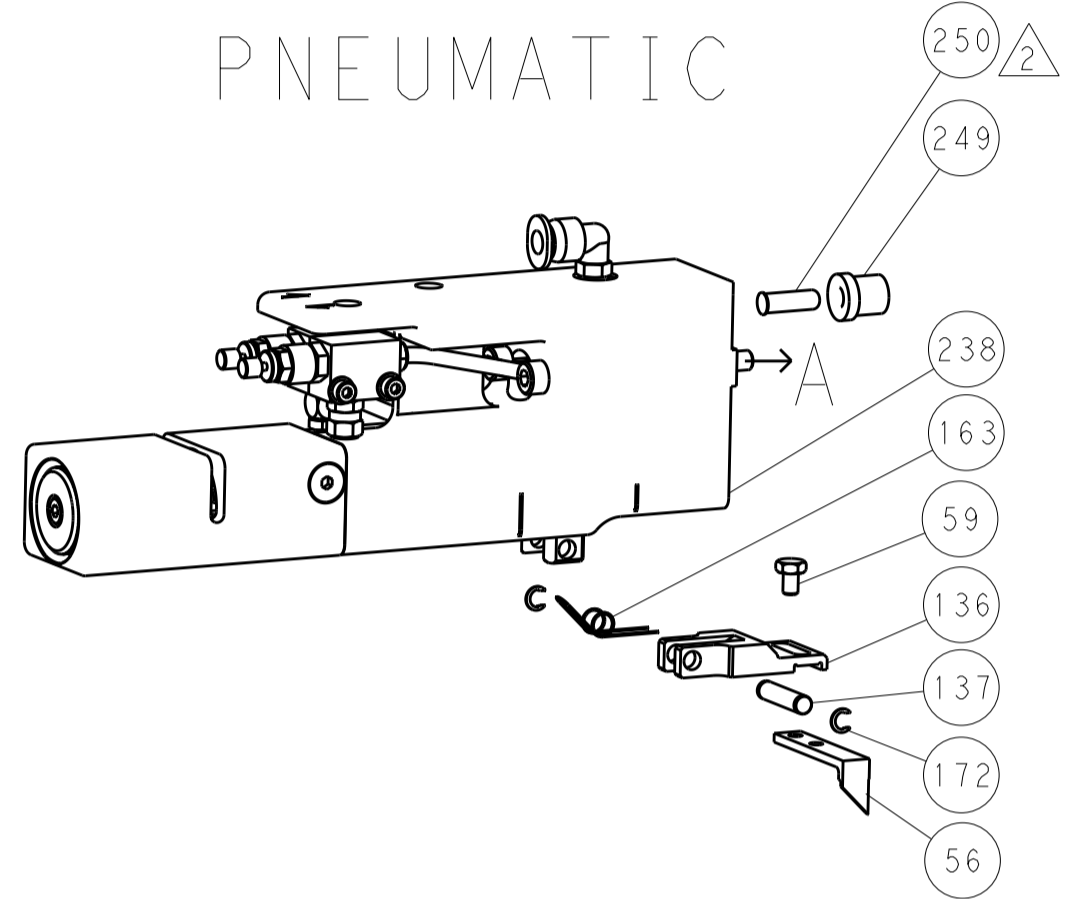

### SERVO LATCH PLATE



### CAM POSITIONS

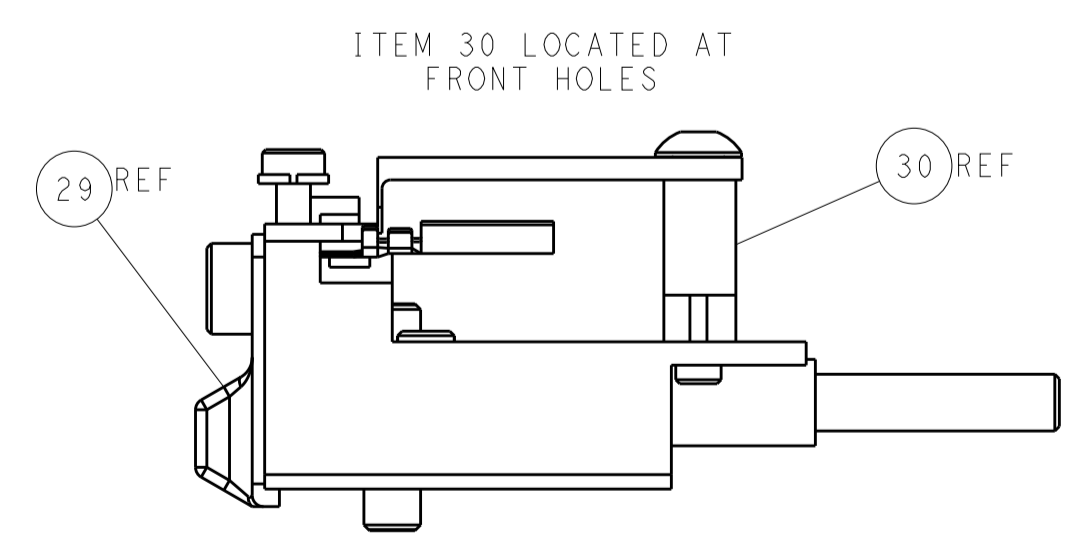
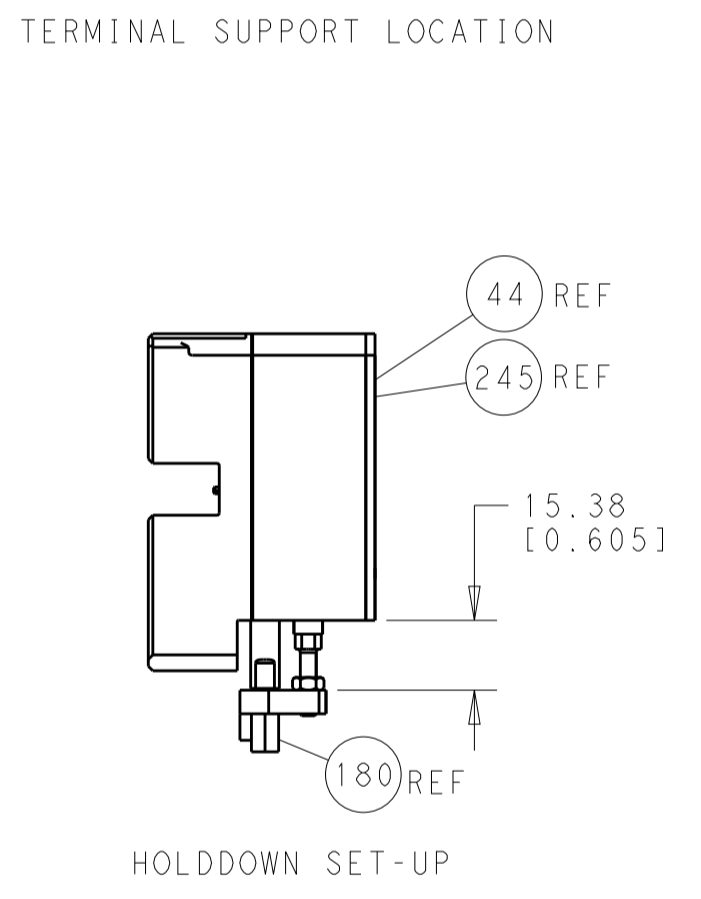
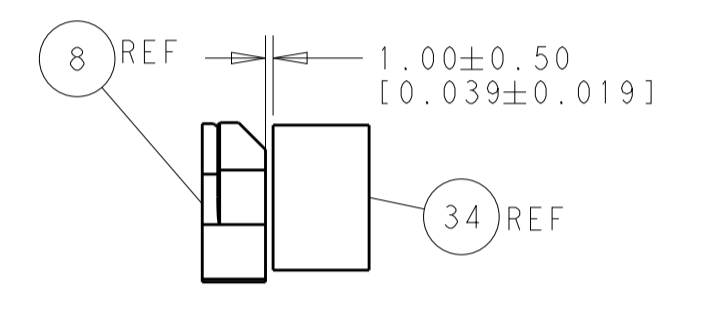
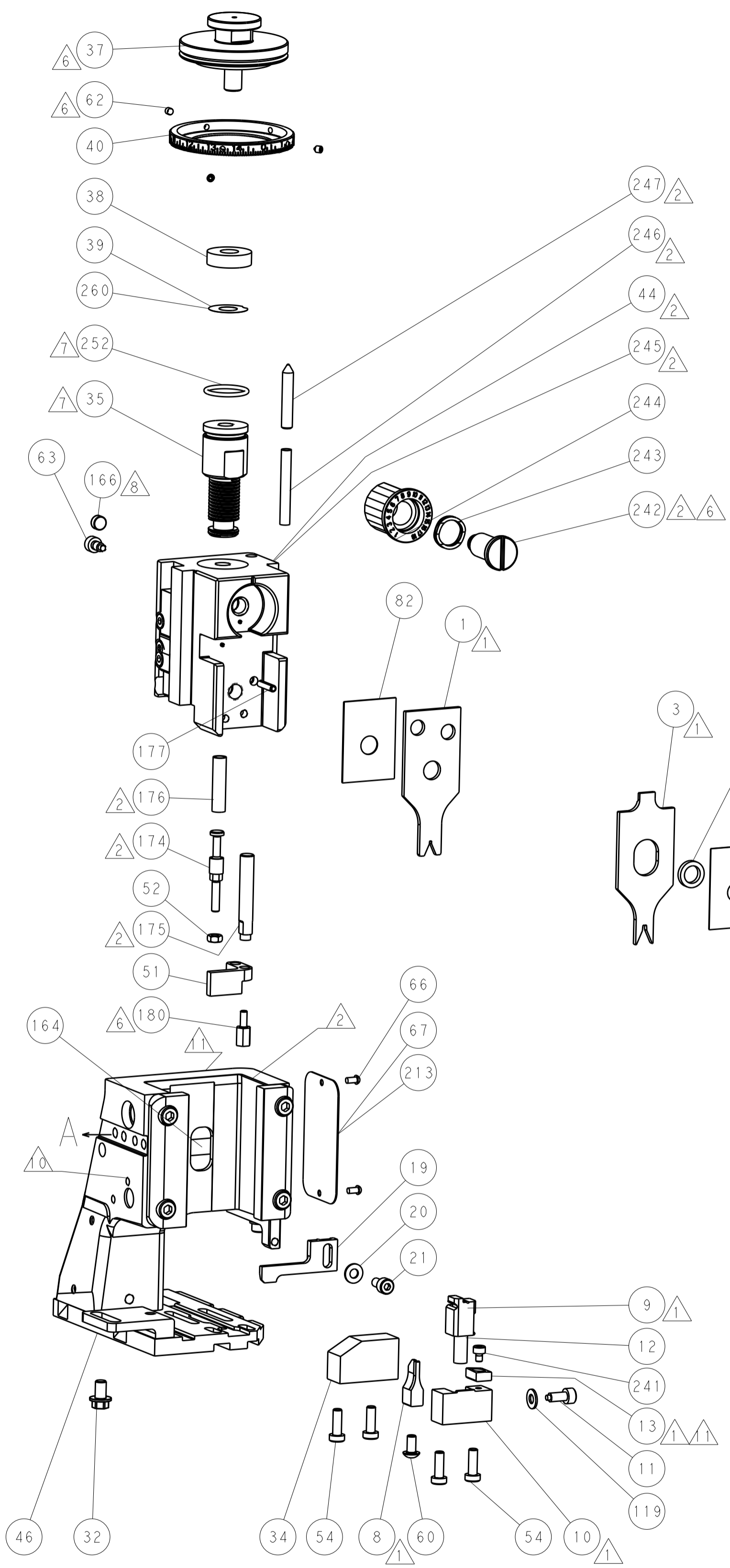
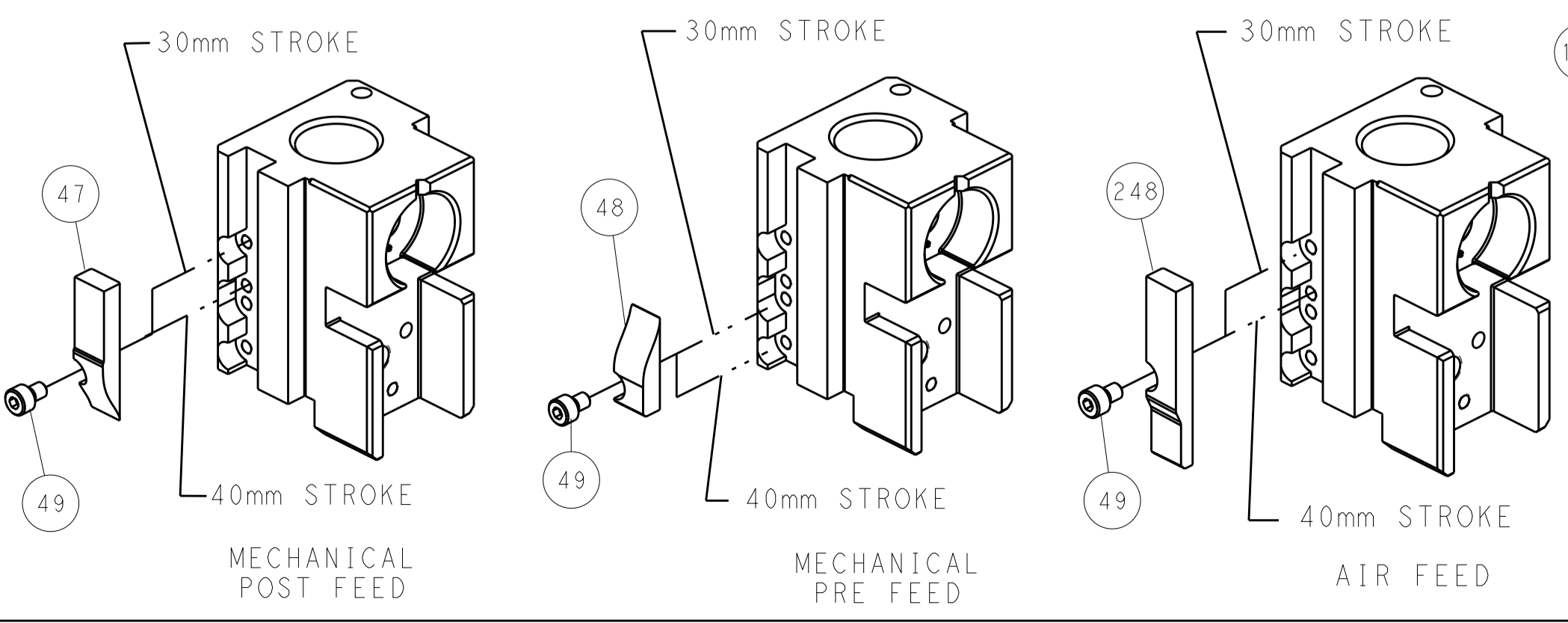

**ATLANTIC VERSION**  
 Shown on sheets 1 of 4 & 2 of 4  
 (Pacific version shown on sheets 3 of 4 & 4 of 4)

DIMENSIONS:		TOLERANCES UNLESS OTHERWISE SPECIFIED:		DWN 06AUG2013		TE Connectivity	
mm	0 PLC ±0.5	1 PLC ±0.5	2 PLC ±0.13	3 PLC ±0.013	4 PLC ±0.001	ANGLES ±0.0001	FINISH
MATERIAL:				CHK G. BAILEY 06AUG2013		NAME Ocean Side Feed Applicator	
APVD H. GUO 06AUG2013				PRODUCT SPEC		RESTRICTED TO	
APPLICATION SPEC				SIZE CAGE CODE DRAWING NO		A1 00779 C=2266016	
WEIGHT				Customer Accessible Production Drawing		SCALE 1:2 SHEET 2 of 4 REV A	

PACIFIC VERSION TERMINATOR INTERFACE ADAPTER	PART NUMBER	REVISION	DESCRIPTION	FEED TYPE	APPLICATOR STYLE CONVERSION CHART						
					CONVERT TO	PART NUMBERS REQUIRED					
	2-2266016-1	A	FINE CRIMP HEIGHT ADJUST	MECHANICAL	PNEUMATIC FEED	2119950-1	1338685-1	5-18022-5	2119641-2	2119799-1	2063440-1
					SERVO LATCH PLATE	2119951-1	-	8-2266016-5	1901094-3	1-1752354-8	2168400-6 (QUANTITY 2)
					SMART APPLICATOR	2161326-1	-	8-2266016-4	-	-	-
	2-2266016-2	A	FINE CRIMP HEIGHT ADJUST	PNEUMATIC	MECHANICAL FEED	2119949-1	1338685-1	5-18022-5	2119653-2	-	-
					SERVO LATCH PLATE	2119951-1	-	8-2266016-5	1901094-3	1-1752354-8	2168400-6 (QUANTITY 2)
					SMART APPLICATOR	2161326-1	-	8-2266016-4	-	-	-
	2-2266016-5	A	FINE CRIMP HEIGHT ADJUST	SERVO LATCH PLATE	MECHANICAL FEED	2119949-1	1338685-1	5-18022-5	2119653-2	-	-
					PNEUMATIC FEED	2119950-1	1338685-1	5-18022-5	2119641-2	2119799-1	2063440-1
	2-2266016-7	A	FINE CRIMP HEIGHT ADJUST	NONE	-	-	-	-	-	-	-
	7-2266016-7	A	CRIMP TOOLING KIT	-	-	-	-	-	-	-	-

APPLICATOR DATA		
CRIMP WIRE	SIZE	TYPE
	1.07 mm [.042]	F
INSUL	2.03 mm [.080]	F
APPLICATOR INSTRUCTIONS 408-10389		

TERMINAL DATA: ALEX TERMINAL TE CRIMP SPECIFICATION			
TERMINAL NAME: .165 MALE CRIMP TERMINAL			
WIRE STRIP LENGTH		INSULATION DIAMETER RANGE	
2.56-3.22 mm [.101-.127 IN]		Ø 1.78 mm MAX[.070 IN MAX]	
TERMINAL APPLICATION SPECIFICATION	NONE	-	-
TERMINALS APPLIED			
TE TERMINAL	ALEX TERMINAL	TE TERMINAL	ALEX TERMINAL
2113365-1	4257T1	2113365-3	4257T-xGF
2113365-2	4257T1-xGC		

WIRE SIZE	CRIMP HEIGHT mm [INCH]	CRIMP HEIGHT REFERENCE SETTING
22 AWG	0.90 +/- 0.05 [0.035 +/- .002]	7.7
24 AWG	0.82 +/- 0.05 [0.032 +/- .002]	8.5
26 AWG	0.73 +/- 0.05 [0.029 +/- .002]	9.5
28 AWG	0.69 +/- 0.05 [0.027 +/- .002]	9.9

- RECOMMENDED SPARE PARTS
- GREASE BEARING SURFACES LIGHTLY
- 3. LUBRICATE DAILY PER THE APPLICATOR INSTRUCTION SHEET SUPPLIED WITH THE APPLICATOR.
- APPLICATOR SPECIFIC DATA TO BE ENTERED INTO BLANK MEMORY CHIP AT ASSEMBLY. SEE BELOW FOR PART NUMBER:  
 MECHANICAL FEED WITH "SMART APPLICATOR" CONVERSION: 8-2266016-4  
 PNEUMATIC FEED WITH "SMART APPLICATOR" CONVERSION: 8-2266016-4  
 SERVO FEED WITH "FINE CRIMP HEIGHT ADJUST": 8-2266016-5
- 5. ADJUSTMENT OF THE STRIPPER MAY BE REQUIRED WHEN MOVING THE APPLICATOR BETWEEN BENCH AND LEADMAKER APPLICATIONS.
- APPLY PART NUMBER 1-23419-5 LOCTITE TO THREADS OF ITEMS 62, 180 & 242.
- GREASE THREADS, GROOVE AND O-RING ON ITEMS 139 & 152.
- MAGNET MUST BE ORIENTED CORRECTLY IN ORDER TO PROPERLY ACTUATE THE COUNTER.
- CRIMP HEIGHT REFERENCE SETTING WAS THE SETTING USED WHEN THE APPLICATOR WAS QUALIFIED AT THE FACTORY. ADJUSTMENT MAY BE NECESSARY WHEN RUNNING APPLICATOR IN THE FIELD.
- SPARE FEED CAM STORAGE LOCATION REFER TO INSTRUCTION SHEET FOR ADDITIONAL INFORMATION.
- TO CONVERT THE APPLICATOR TO A NON-CARRIER CUTTING STYLE, REMOVE ITEM 13 AND ATTACH TO THE LOCATION ON BACK SIDE OF THE HOUSING. REFER TO INSTRUCTION SHEET FOR ADDITIONAL INFORMATION.
- TERMINAL LUBRICANT IS RECOMMENDED.

\*WARNING  
 ON INSTALLATION, SET WIRE DISC, ITEM 40 TO LARGEST WIRE SIZE SETTING. USE OF SETTINGS BELOW MINIMUM REQUIRED CRIMP HEIGHT SETTING WILL CAUSE DAMAGE TO CRIMP TOOLING.

-	1	1	1	1	2119782-1	FINE ADJUST HEAD ASM, PACIFIC STYLE	251
-	-	-	-	-	2119640-1	PUSH ROD, AIR FEED	250
-	-	-	-	-	2079988-1	BUSHING, LCH5-12, MISUMI	249
-	1	1	1	1	1-22279-3	SPRING, COMPRESSION	246
-	1	1	1	1	2119082-8	CAM, SNAIL, INSULATION ADJUSTMENT	244
-	1	1	1	1	2079764-1	WASHER, WAVE SPRING, CREST-TO-CREST	243
-	1	1	1	1	2119083-1	RETAINER, INSULATION DIAL	242
-77	-27	-25	-22	-21	PART NO	DESCRIPTION	ITEM NO

PACIFIC VERSION  
 Shown on sheets 3 of 4 & 4 of 4  
 (Atlantic version shown on sheets 1 of 4 & 2 of 4)

SET UP GAUGE	LOC	DIST	REVISIONS			
2119599-1	A	66	REV	DATE	BY	APPD
			-	SEE SHEET 1	-	-

-	1	1	1	1	7-18023-7	SCR, SKT HD CAP M3 X 4.0	241
-	-	2	-	-	2168400-6	SHCS, LOW HEAD, RoHS, M5 X 16	240
-	-	-	-	1	2119580-1	MECHANICAL FEED ASSEMBLY	239
-	-	-	-	1	2063440-1	AIR FEED MODULE	238
-	-	1	-	-	2119740-2	TAG, IDENTIFICATION	213
-	-	1	-	-	1901094-3	SPACER, FEEDER	198
-	1	1	1	1	1-1752354-8	STANDOFF, HOLD-DOWN	180
-	1	1	1	1	6-993111-6	PIN, SLOTTED SPRING 3.0 X 14.0	177
-	1	1	1	1	8-22280-7	SPRING, COMPRESSION	176
-	1	1	1	1	1752353-2	GUIDE PIN, HOLDDOWN	175
-	1	1	1	1	1901680-2	GUIDE PIN, HOLDDOWN	174
-	-	-	2	-	21045-3	RING, RETAIN, EXTERN, 3/16 CRESCENT	172
-	1	1	1	1	994969-1	MAGNET, RARE EARTH HIGH ENERGY	166
-	REF	REF	REF	REF	994970-2	COUNTER, MAGNETIC	164
-	-	-	-	1	240638-1	SPRING, FEED FINGER	163
-	1	1	1	1	8-21084-1	O-RING, .801 ID, .070 DIA, MAT.	152
-	-	-	-	1	2119641-2	FEED CAM, AIR FEED	151
-	1	1	1	1	2119798-2	DETENT PIN	145
-	1	1	1	1	2079383-8	SCR, BHSC, RoHS (M4 X 16)	144
-	4	4	4	4	2168400-5	SHCS, LOW HEAD, RoHS, M4 X 20	143
-	-	-	-	1	2119653-2	FEED CAM, POST FEED	142
-	1	1	1	1	1-2119656-0	APPLICATOR BASIC ASSEMBLY, SF	141
-	1	1	1	1	2119650-1	RAM, ASIAN STYLE, SIDE FEED	140
-	1	1	1	1	2119092-2	BOLT, ADJUSTMENT	139
-	-	-	-	1	3-23627-7	PIN, RETAIN, GRVD, 3/16 X .854	137
-	-	-	-	1	2119799-1	HOLDER, FEED FINGER, AF	136
-	-	REF	-	-	SEE NOTE 4	MEMORY CHIP, PROGRAMMED	135
-	-	1	-	-	1633743-1	SERVO FEED LATCH ASM	133
-	1	1	1	1	1-18028-2	WASHER, FLAT, REG M4	119
-	-	REF	-	-	2119944-1	FEED FINGER ASSEMBLY, SF	117
-	1	1	1	1	2119955-1	ASSY, LUBRICATOR, SIDE FEED	113
-	1	1	1	1	455888-5	SPACER, CRIMPER	82
-	1	1	1	1	5-547505-2	SPRING, COMPRESSION	77
-	1	1	1	1	854769-4	HOLDER, INS	74
-	1	1	1	1	2119956-1	DOCUMENTATION PACKAGE	71
-	1	-	1	1	2119740-1	TAG, IDENTIFICATION	67
-	2	2	2	2	2168078-1	SCREW, DRIVE, RH, RoHS, 2 x .188	66
-	1	1	1	1	2119793-1	LIMITER, ADJUSTMENT BOLT	63
-	3	3	3	3	992763-5	SCR, SET, SOC, CONE POINT, M3 X 4.0	62
-	-	-	-	1	5-18022-5	SCR, HEX HD CAP, M4 X 6.0	59
-	1	1	1	1	21028-2	PIN, SLOTTED SPRING .062 X .250	58
-	-	-	-	1	1338685-1	PAWL, FEED	56
-	1	1	1	1	1-5018030-0	NUT, HEX, REG, RoHS, M3.5	52
-	1	1	1	1	1901681-1	HOLDDOWN, TERMINAL	51
-	-	-	-	1	18023-9	SCR, SKT HD CAP M4 X 6.0	49
-	-	-	-	1	2119652-1	FEED CAM, PRE FEED	48
-	1	1	1	1	2079383-7	SCR, BHSC, RoHS (M8 X 25)	41
-	1	1	1	1	2119645-1	DISC, NUMBERED FA WIRE ADJUSTMENT	40
-	1	1	1	1	2119957-1	APPLICATOR SHIM PACK	39
-	1	1	1	1	2119644-1	RAM WASHER, PRECISION	38
-	1	1	1	1	2-1752356-0	SUPPORT, TERMINAL	34
-	2	2	2	2	2079383-5	SCR, BHSC, RoHS (M4 X 20)	33
-	1	1	1	1	2161328-1	HEX HEAD, FLANGED, M5 X 8mm LONG	32
-	1	1	1	1	1320908-3	SPACER, STRIP GUIDE	30
-	1	1	1	1	2119959-1	ASSEMBLY, STRIP GUIDE	29
-	1	1	1	1	455888-3	SPACER, CRIMPER	28
-	1	1	1	1	1320928-2	STRIP GUIDE	24
-	1	1	1	1	2168083-2	SCR, SKT HD CAP, RoHS, M4 X 8.0	21
-	1	1	1	1	1-18028-2	WASHER, FLAT, REG M4	20
-	1	1	1	1	2119533-1	STRIPPER, SIDE FEED	19
-	1	1	1	1	2119806-1	INSERT, SHEAR	13
-	1	1	1	1	3-22280-3	SPRING, COMPRESSION	12
-	1	1	1	1	1-356885-4	STOP, SHEAR	11
-	1	1	1	1	2119805-1	SHEAR HOLDER, FRONT	10
-	1	1	1	1	1633861-1	SHEAR, FLOATING	9
-	1	1	1	1	1633916-5	ANVIL, COMBINATION	8
-	-	-	-	-	-	-	7
-	-	-	-	-	-	-	6
-	1	1	1	1	2119780-4	DEPRESSOR, SHEAR	5
-	1	1	1	1	1-238011-7	BLOCK, CRIMPER SPACER	4
-	1	1	1	1	3-1633962-8	CRIMPER, INSULATION F PREMIUM	3
-	-	-	-	-	-	-	2
-	1	1	1	1	4-1633713-8	CRIMPER, WIRE PREMIUM	1
-77	-27	-25	-22	-21	PART NO	DESCRIPTION	ITEM NO

DIMENSIONS:		TOLERANCES UNLESS OTHERWISE SPECIFIED:		OWN	CHK	APPD	NAME	
mm	0 PLC	±		Y. YIN	06AUG2013	06AUG2013	TE Connectivity Harrisburg, PA 17105-3608	
	1 PLC	±0.5		G. BAILEY			Ocean Side Feed Applicator	
	2 PLC	±0.13					SIZE CASE CODE DRAWING NO RESTRICTED TO	
	3 PLC	±0.013					A1 00779 ©=2266016	
	4 PLC	±0.001					Customer Accessible Production Drawing	
	ANGLES	±0.0001					SCALE 1:2 SHEET 3 OF 4 REV A	

LOC	DIST	REVISIONS					
		P	LTN	DESCRIPTION	DATE	DWN	APVD
A	66	-	-	SEE SHEET 1	-	-	-

# FEED TYPE MECHANICAL

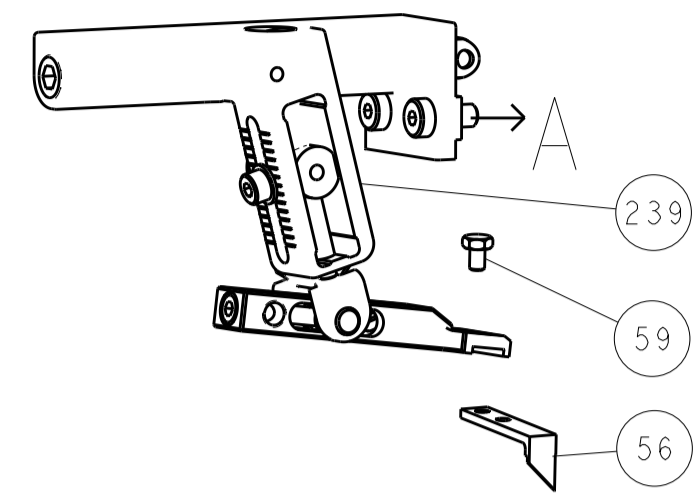

# PNEUMATIC

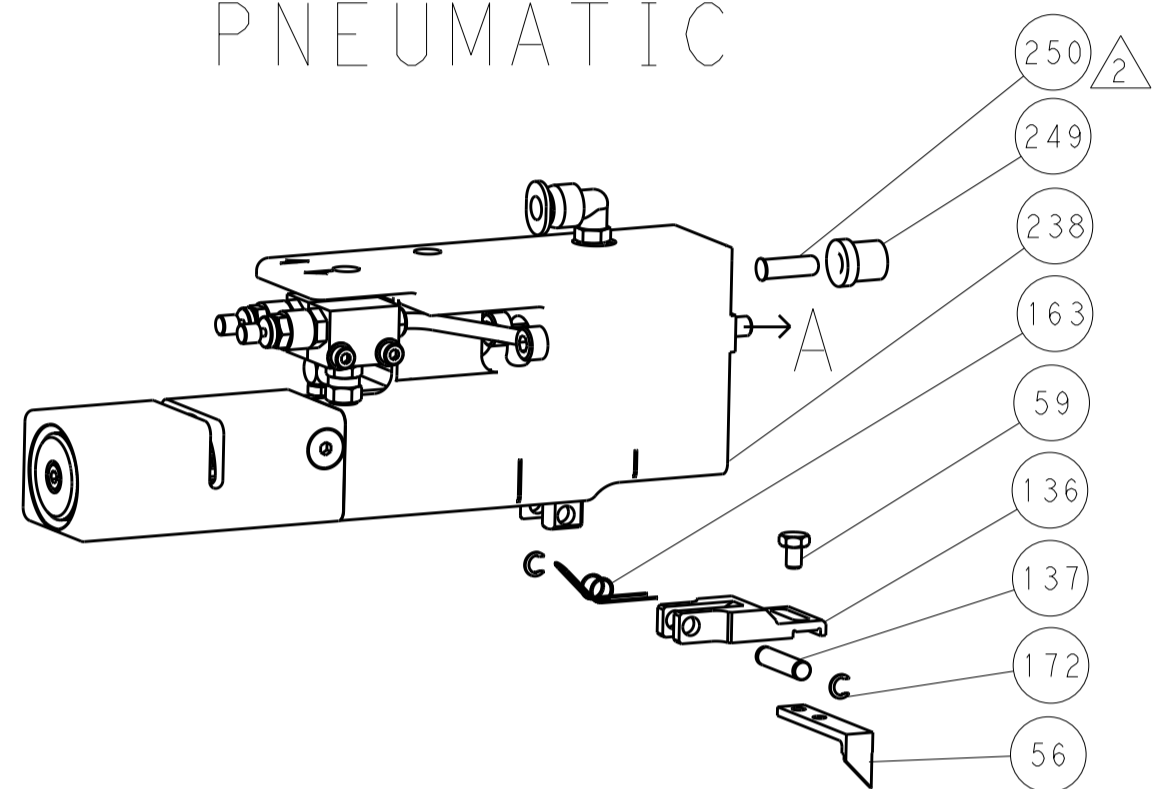

# SERVO LATCH PLATE

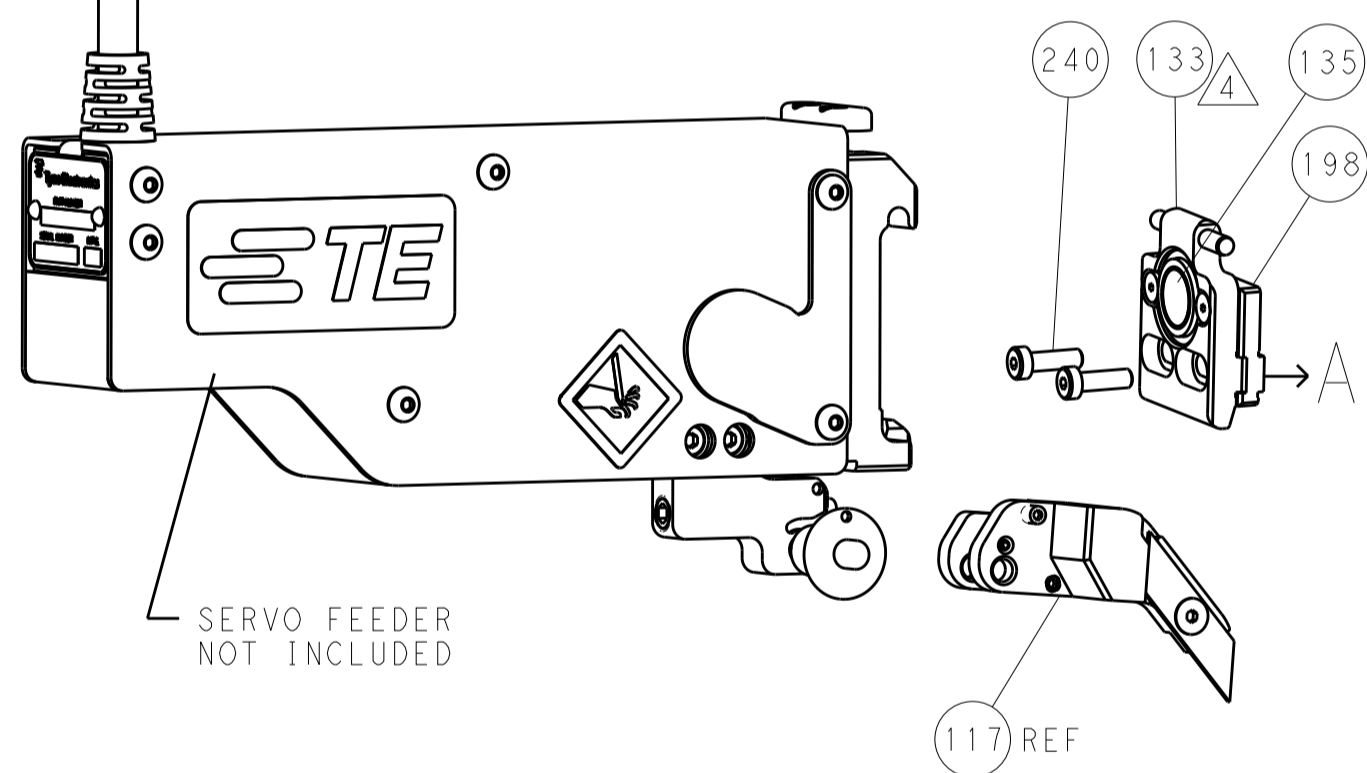

# CAM POSITIONS

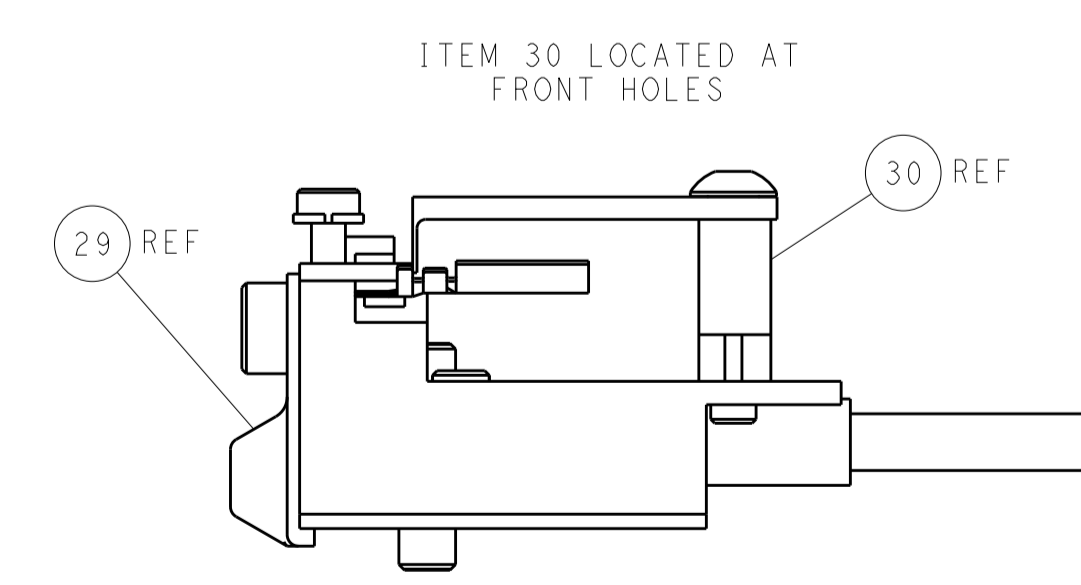
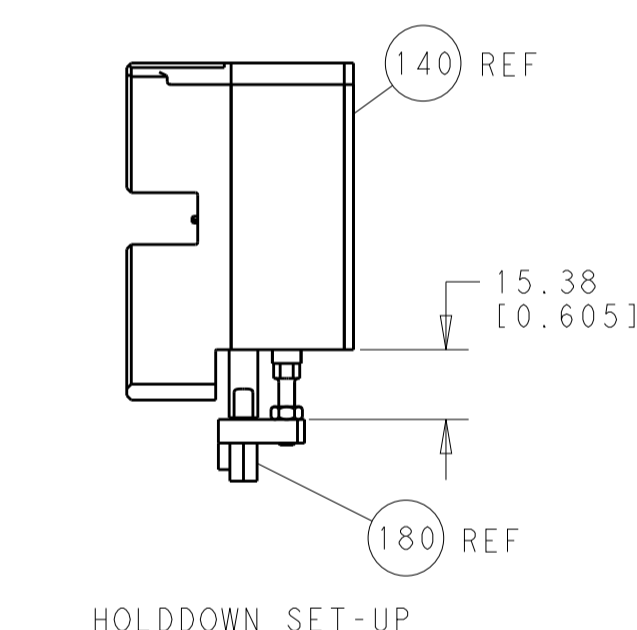
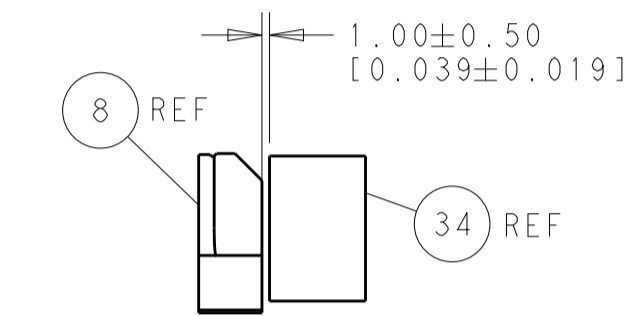
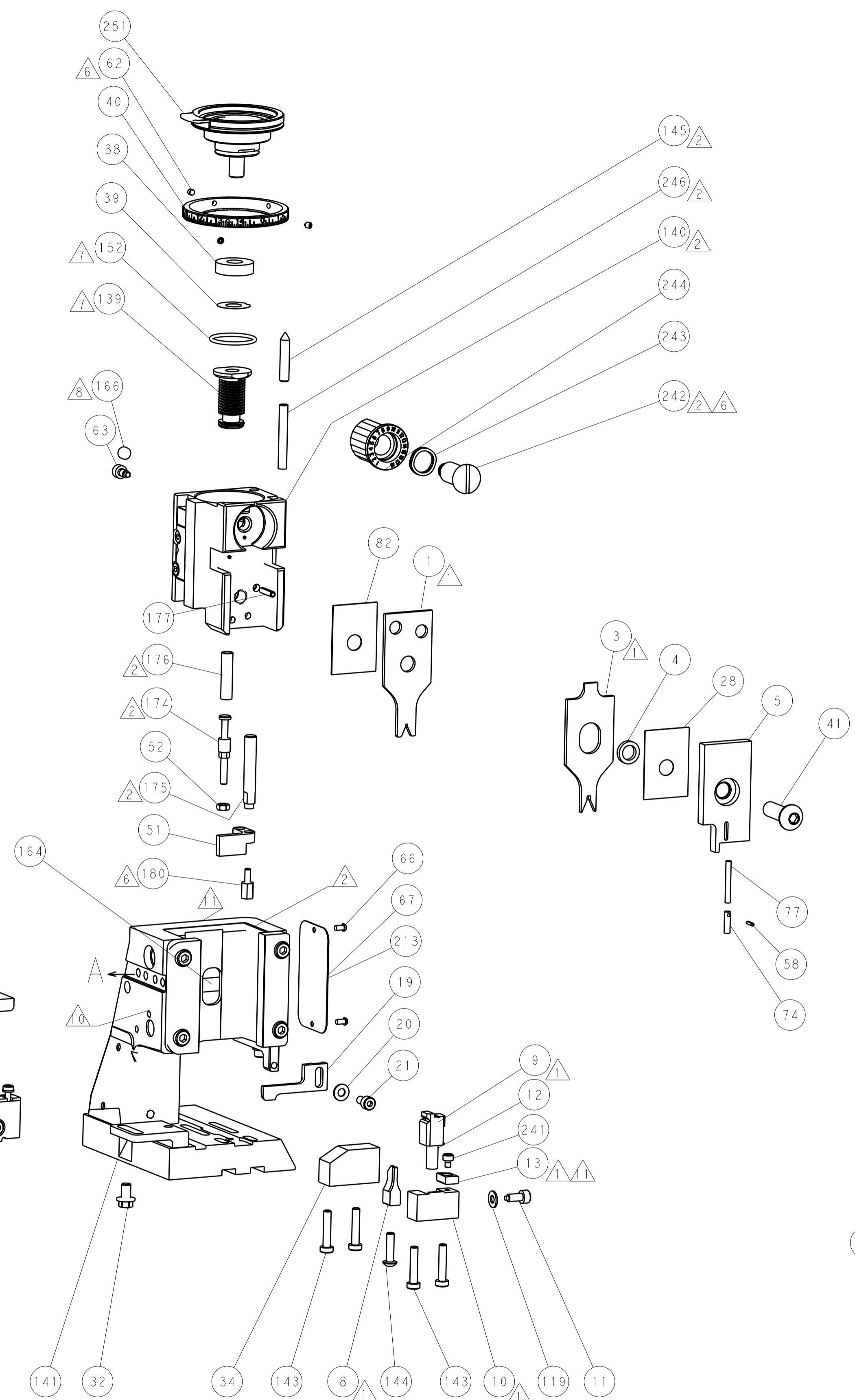
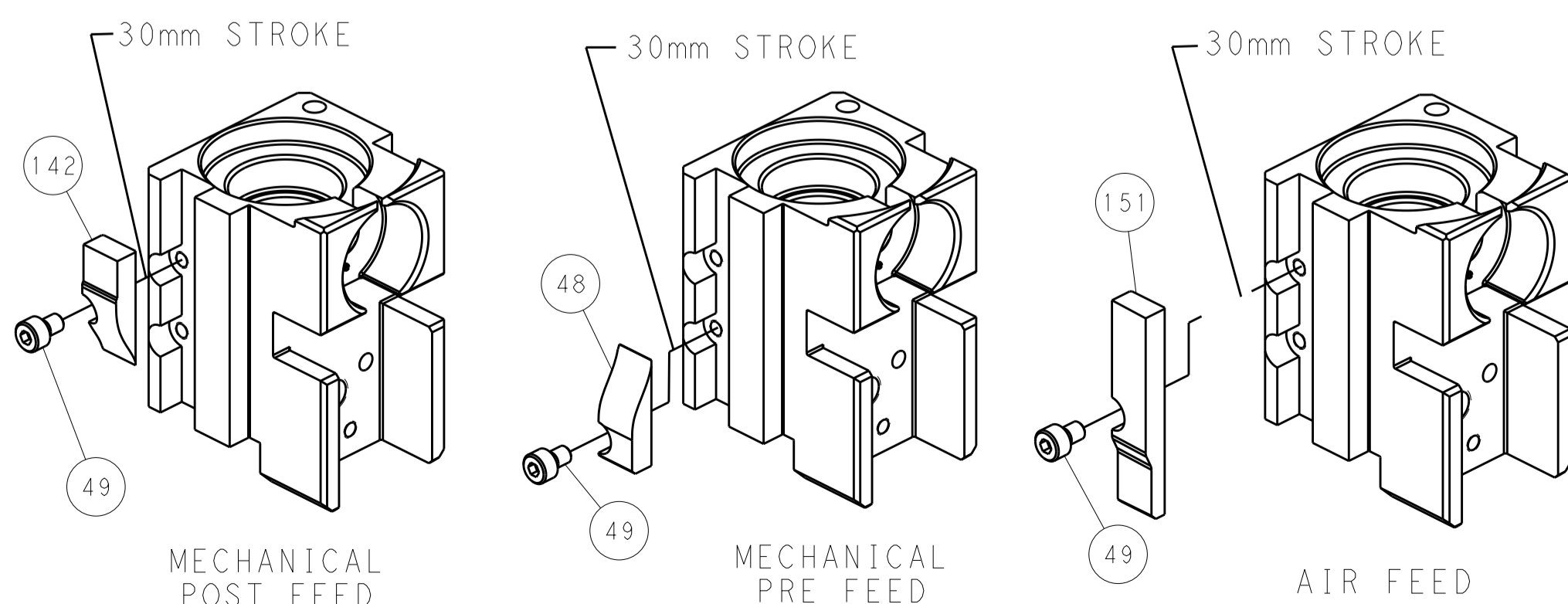

**PACIFIC VERSION**  
 Shown on sheets 3 of 4 & 4 of 4  
 (Atlantic version shown on sheets 1 of 4 & 2 of 4)

DIMENSIONS:		TOLERANCES UNLESS OTHERWISE SPECIFIED:		DWN Y. YIN 06AUG2013		TE Connectivity	
mm	0 PLC ±0.5	1 PLC ±0.5	2 PLC ±0.13	3 PLC ±0.013	4 PLC ±0.001	APVD G. BAILEY 06AUG2013	Harrisburg, PA 17105-3608
MATERIAL:		FINISH:		NAME		Ocean Side Feed Applicator	
				SIZE CAGE CODE DRAWING NO		RESTRICTED TO	
				A1 00779 C=2266016			
				Customer Accessible Production Drawing		SCALE 1:2 SHEET 4 OF 4 REV A	