

THIS DRAWING IS UNPUBLISHED. RELEASED FOR PUBLICATION .1997  
 © COPYRIGHT 1997 BY - ALL RIGHTS RESERVED.

REVISIONS					
P	LTR	DESCRIPTION	DATE	DWN	APVD
A2		Released as per ECR-07-030419	17.12.07	SP	TS
A3		REVISED PER ECO-09-027197	11FEB10	KK	HMR
A4		REVISED PER ECR-18-004438	05APR2018	GCM	JB

PN 1-5 & 2-5

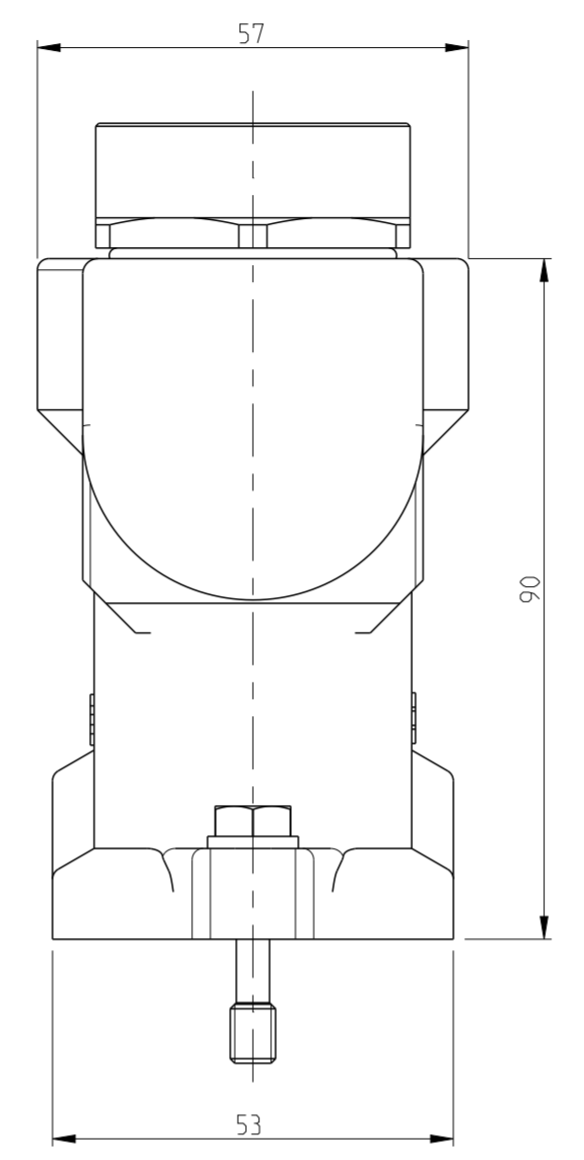
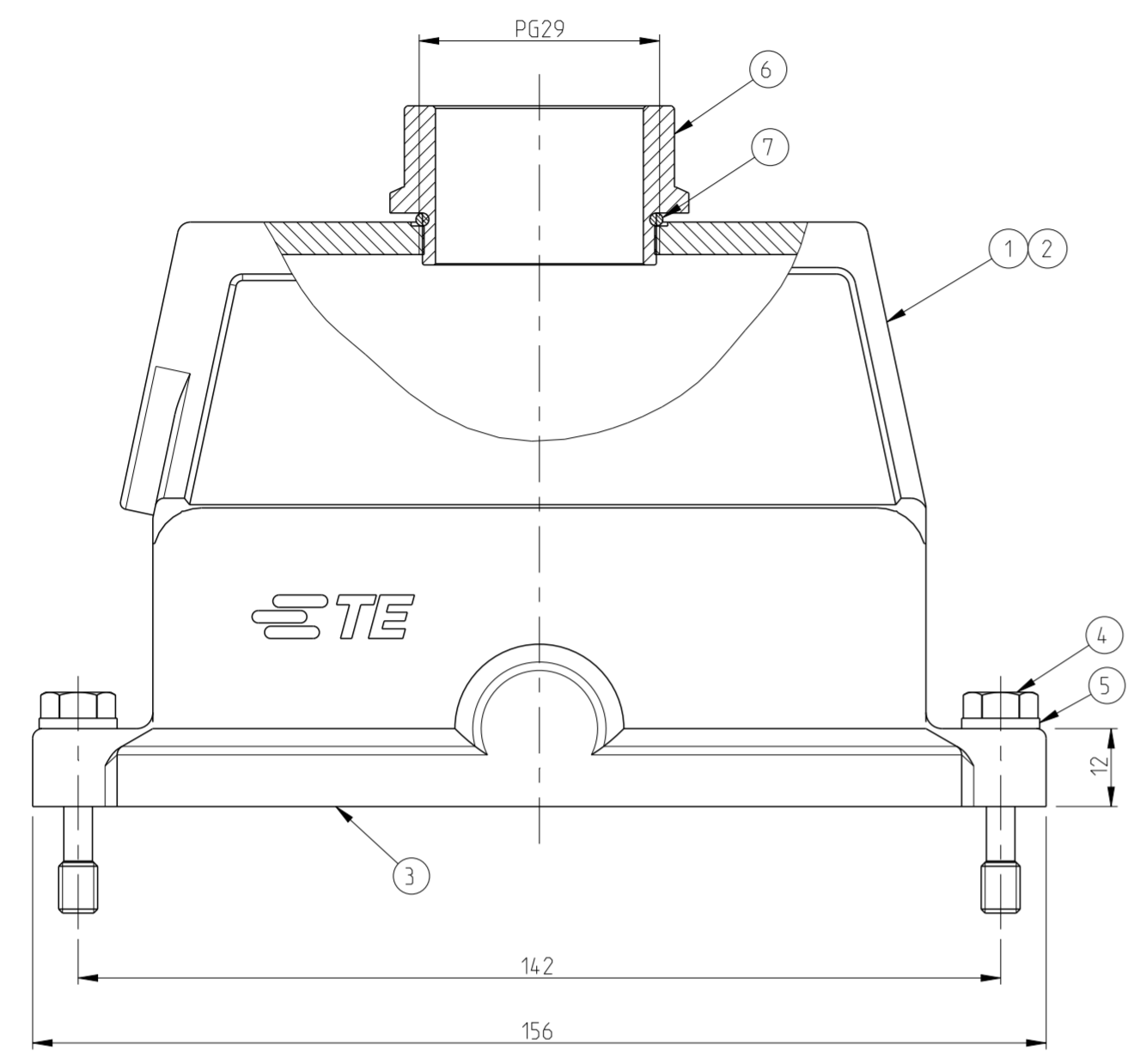

- NOTES
- 1 Material: Housing: Aluminium Diecasting Alloy  
Seals: Neoprene
  - 2 Surface:- varnish-grey  
Aluminium oxide+  
Varnish black
  - 3 Varnish on the inside not necessary
  - 4 Packaging quantity: 5 pieces in a box
  - 5 OBSOLETE PARTS: OBSOLETE CIS STREAMLINING  
PER D.RENAUD/D.SINISI

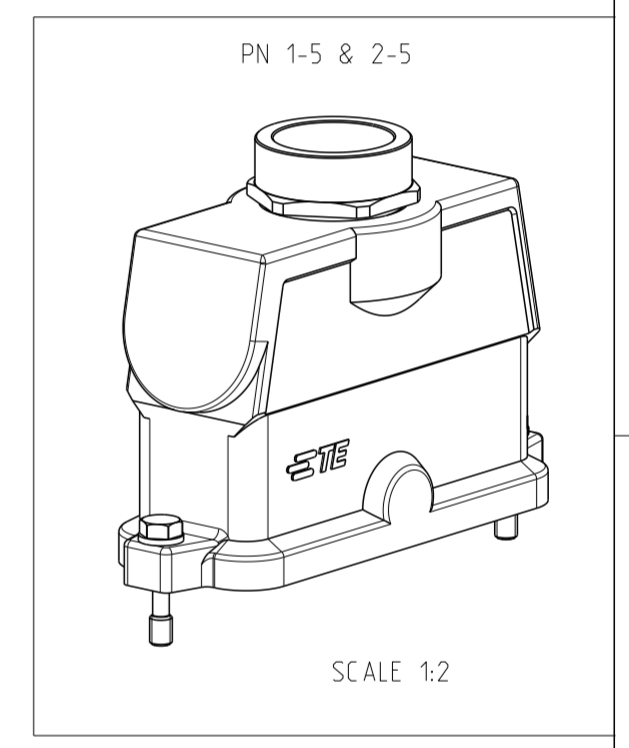

5  
OBSOLETE

QTY	ITEM NO	DESCRIPTION	MATERIAL	SURFACE	COLOR	ITEM NO	REMARKS
1	1	O-Ring PG29	Neoprene	-	Black	7	
1	1	Adaptor PG29	Brass	Nickel plated		6	
2	2	Spring washer	Stainless steel	Blank		5	
2	2	Fixing screw	Stainless steel	Blank		4	
1	1	O-Ring Bg8	Neoprene	-	Black	3	
1	-	Hood HIP Bg8	Aluminium	Aluminium oxide	Black	2	
-	1	Hood HIP Bg8	Aluminium	-	Grey	1	
2-5	1-5	DESCRIPTION	MATERIAL	SURFACE	COLOR	ITEM NO	REMARKS
ORDERING TEXT							
HIP.24/64.STO.1.29.Z							
HIP-K.24/64.STO.1.29.Z							

THIS DRAWING IS A CONTROLLED DOCUMENT.		DWN Schneider 12.06.01	TE Connectivity			
		CHK Schweiger 12.06.01				
DIMENSIONS: mm		TOLERANCES UNLESS OTHERWISE SPECIFIED: 0 PLC ± 1 PLC ± 2 PLC ± 3 PLC ± 4 PLC ± ANGLES ±		NAME Hood HIP Size8 HIP.24/64.STO.1.29.Z		
MATERIAL		FINISH		PRODUCT SPEC 108-74030		
				APPLICATION SPEC 114-74017		
				WEIGHT 540 g		
				SIZE A2		
				CAGE CODE 00779		
				DRAWING NO C-1102663		
				RESTRICTED TO		
				SCALE 1:1		
				SHEET 1 OF 1		
				REV A4		